

# SCAG

## POWER EQUIPMENT

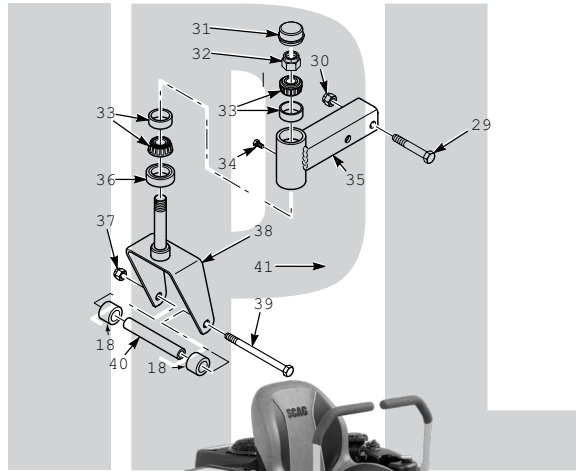

# ILLUSTRATED PARTS MANUAL

## Model SZL Liberty Z

This manual covers the operating instructions and illustrated parts list for:

<b>SZL-36H-18FR</b>	<b>with a serial number of</b>	<b>Y7300001 to Y7399999</b>
<b>SZL-36H-20KT</b>	<b>with a serial number of</b>	<b>Y7400001 to Y7499999</b>
<b>SZL-36H-20PX</b>	<b>with a serial number of</b>	<b>Y7500001 to Y7599999</b>
<b>SZL-42H-21FR</b>	<b>with a serial number of</b>	<b>Y7600001 to Y7699999</b>
<b>SZL-42H-22KT</b>	<b>with a serial number of</b>	<b>Y7700001 to Y7799999</b>
<b>SZL-42H-22PX</b>	<b>with a serial number of</b>	<b>Y7800001 to Y7899999</b>
<b>SZL-48H-21FR</b>	<b>with a serial number of</b>	<b>Y7900001 to Y7999999</b>
<b>SZL-48H-22KT</b>	<b>with a serial number of</b>	<b>Y8000001 to Y8099999</b>
<b>SZL-48H-22PX</b>	<b>with a serial number of</b>	<b>Y8100001 to Y8199999</b>
<b>SZL-48H-24SR</b>	<b>with a serial number of</b>	<b>Y8200001 to Y8299999</b>
<b>SZL-52H-23FR</b>	<b>with a serial number of</b>	<b>Y8300001 to Y8399999</b>
<b>SZL-52H-24KT</b>	<b>with a serial number of</b>	<b>Y8400001 to Y8499999</b>
<b>SZL-52H-24PX</b>	<b>with a serial number of</b>	<b>Y8500001 to Y8599999</b>
<b>SZL-52H-24SR</b>	<b>with a serial number of</b>	<b>Y8600001 to Y8699999</b>
<b>SZL-61H-24FR</b>	<b>with a serial number of</b>	<b>Y8700001 to Y8799999</b>
<b>SZL-61H-26KT</b>	<b>with a serial number of</b>	<b>Y8800001 to Y8899999</b>



## Table of Contents

36H CUTTER DECK .....	2
42H CUTTER DECK .....	4
48H, 52H & 61H CUTTER DECKS.....	6
36H & 42H CUTTER DECK CONTROLS.....	8
48H, 52H & 61H CUTTER DECK CONTROLS .....	10
36H & 42H SHEET METAL COMPONENTS.....	12
48H, 52H & 61H SHEET METAL COMPONENTS.....	14
36H & 42H DRIVE SYSTEM COMPONENTS - HYDRO-GEAR AXLES .....	16
48H, 52H & 61H DRIVE SYSTEM COMPONENTS - TUFF TORQ AXLES.....	18
36 & 42 ELECTRICAL SYSTEM .....	20
48, 52 & 61 ELECTRICAL SYSTEM.....	22
FUEL SYSTEM.....	24
HYDRO-GEAR TRANSAXLE (ZT-2800 36"/42").....	26
TUFF TORQ TRANSAXLE - LH (TZ-450C-X 48", 52", 61 ").....	28
TUFF TORQ TRANSAXLE - RH (TZ-450C-Y 48", 52", 61 ") .....	30
REPLACEMENT DECALS AND INFORMATION PLATES .....	32
ELECTRICAL SCHEMATIC.....	34

### 36H CUTTER DECK

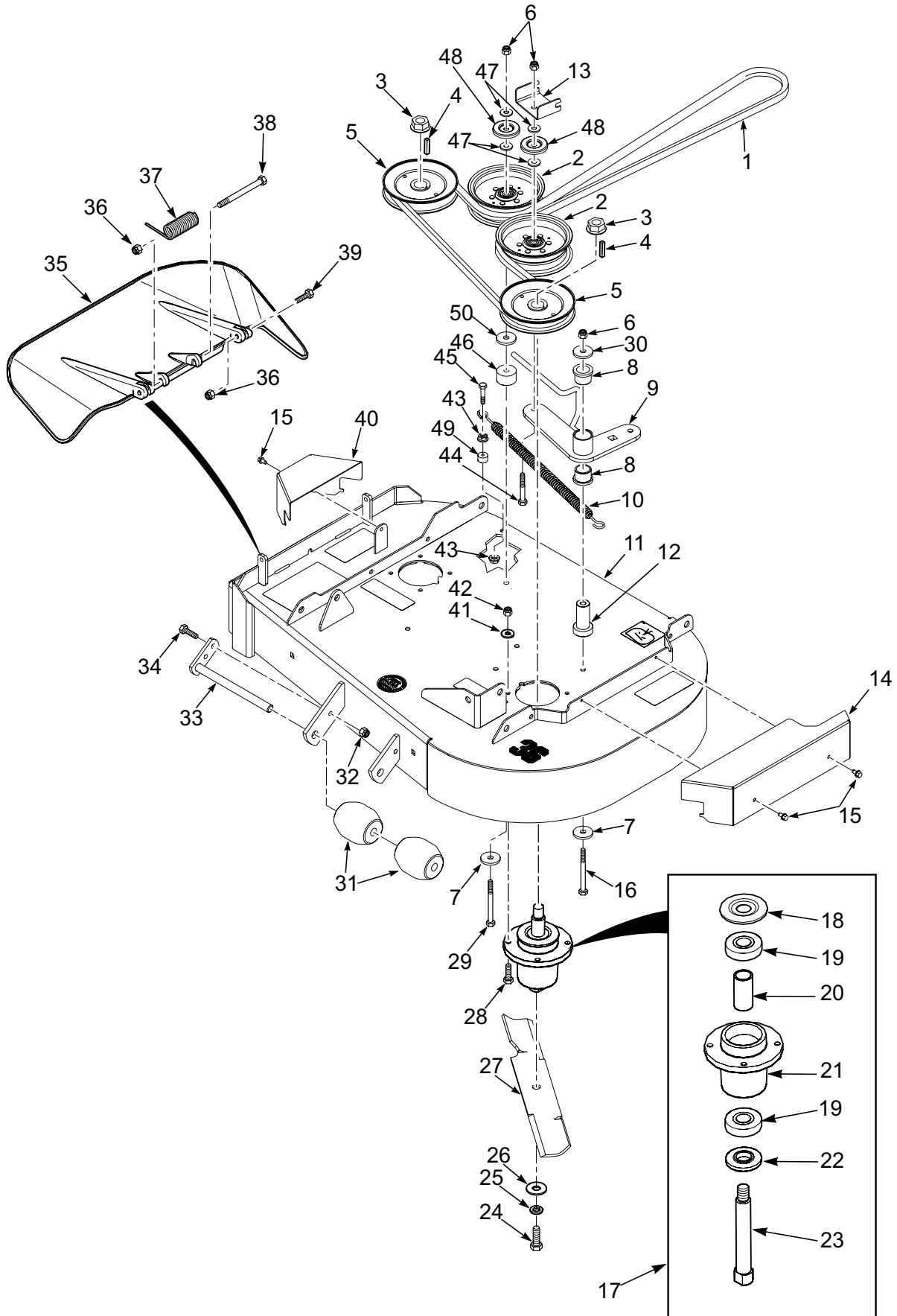

36H CUTTER DECK

Ref. No.	Part No.	Qty	Description
1	485805	1	Belt, Cutter Deck
2	483422	2	Pulley, 5" Idler
3	04112-06	1	Nut, 3/4-16 Spiral Lock
4	04063-01	2	Key, 1/4 x 1/4 x 1-1/4"
5	483324	2	Pulley, 5.73" OD - 25mm Bore
6	04021-09	3	Nut, 3/8-16 Elastic Stop
7	04041-38	2	Flat washer, 3/8-.406 x 2.25 x .188
8	483453-03	2	Bearing, 1" ID
9	462944	1	Pivot, Idler Arm
10	483375	1	Spring, Cutter Deck Idler
11	463333	1	Cutter Deck w/Decals, SMLZ-36
12	43708	1	Pivot, Idler
13	424615	1	Bracket, Belt Guide
14	427325	1	Belt Cover LH SMZL-36
15	04011-29	3	Screw, 1/4-20 x .375"
16	04001-30	1	Bolt, Hex Head 3/8-16 x 4.00
17	461950	2	Spindle Assembly (INCL. 18,19,20,21,22,23)
18	483304	1	Debris Shield
19	483303	2	Bearing
20	43693	1	Spacer
21	462014	1	Spindle Housing Assembly (INCL. 19,20)
22	43694	1	Protector, Bearing
23	43695	1	Shaft, Spindle
24	04001-121	2	Bolt, Hex Head 5/8-11 x 1-1/2"
25	04030-07	2	Lockwasher, 5/8"
26	04043-06	2	Flatwasher, 5/8-.688 x 1.75 x .134 HD
27	482878	2	Cutter Blade, 18"
28	04001-175	8	Bolt, Hex Head 5/16-18 x 1-1/2" Gr.8
29	04001-77	1	Bolt, Hex Head 3/8-16 x 3-1/2"
30	04041-11	1	Flatwasher, 3/8-.406 x 1.50 x .1793
31	482295	2	Wheel, Anti-Scalp
32	04117-01	1	Nut, 5/16-18 Flange Elastic Stop
33	451926	1	Shaft Weldment, Guide Roller
34	04001-09	1	Bolt, Hex Head 5/16-18 x 1"
35	462031	1	Discharge Chute
36	04021-10	2	Nut, 5/16-18 Elastic Stop
37	482245	1	Spring, Discharge Chute
38	04001-154	1	Bolt, Hex Head 5/16-18 x 4-3/4"
39	04001-12	1	Bolt, Hex Head 5/16-18 x 1-3/4"
40	427319	1	Belt Cover, RH SMZL-36
41	04030-03	8	Lockwasher, 5/16"
42	04021-22	8	Nut, 5/16-18 Elastic Stop Grade 8
43	04019-04	2	Nut, 3/8-16 Serrated Flange
44	04001-31	1	Bolt, Hex Head 3/8-16 x 2 1/2"
45	04001-136	1	Bolt, Hex Head 3/8-16 x 1-1/2" Gr.8
46	43711	1	Spacer
47	04043-04	4	Flatwasher, 3/8-.391 x .938 x .105 HD
48	424367	2	Dust Shield
49	43063	1	Spacer, Spring Anchor
50	04043-11	1	Flatwasher, 3/8-.438 x 1.5 x .1793 HD

### 42H CUTTER DECK

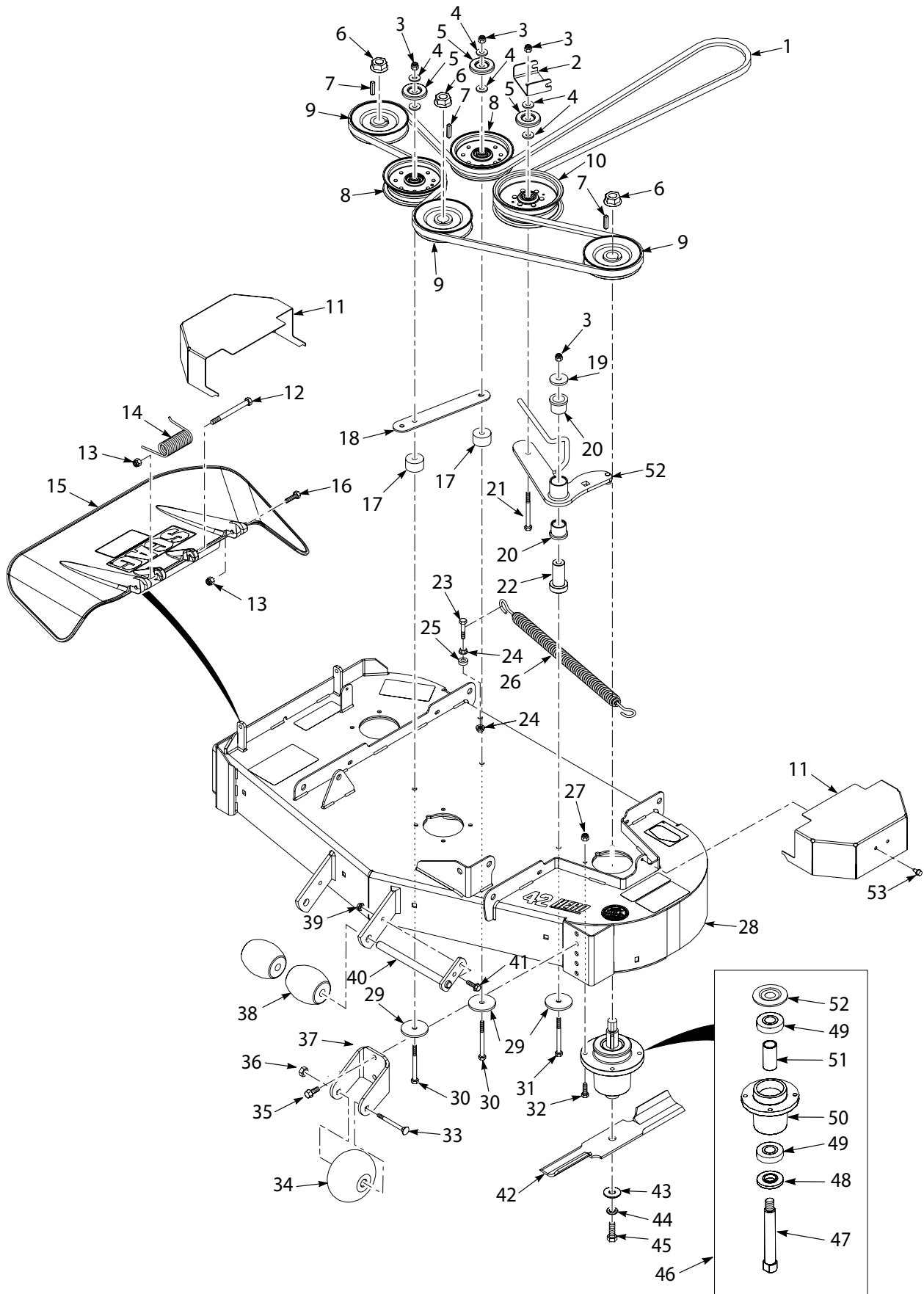

**42H CUTTER DECK**

Ref. No.	Part No.	Qty	Description
1	484695	1	Belt, Cutter Deck
2	424615	1	Bracket, Belt Guide
3	04021-09	3	Locknut, 3/8 - 16 Elastic Stop
4	04043-04		Washer, Flat 3/8 - .391 x .938 x .105 HD
5	424367	3	Dust Shield
6	04112-06	3	Locknut, 3/4 - 16 Spiralock
7	04063-01	3	Key, 1/4 x 1/4 x 1-1/4"
8	483213	2	Pulley, 4.50" Idler
9	486910	3	Pulley, 4.62"
10	483422	1	Pulley, 5.00" Idler
11	428614	2	Belt Cover
12	04001-154	1	Bolt, Hex Head 5/16 - 18 x 4.75"
13	04021-10		Locknut, 5/16 - 18 Elastic Stop
14	482245	1	Spring, Discharge Chute
15	462031	1	Discharge Chute
16	04001-12		Bolt, Hex Head 5/16 - 18 x 1.75"
17	43711	2	Spacer
18	424479	1	Brace, Pulley
19	04043-11	1	Flat Washer, 3/8 - .438 x 1.500 x .1793 HD
20	483453-03	2	Bearing, Plastic
21	04001-31	1	Bolt, Hex Head 3/8 - 16 x 2.50"
22	43708	1	Pivot Idler
23	04001-135	1	Bolt, Hex Head 3/8 - 16 x 1.75"
24	04019-04		Nut, 3/8 - 16 Serrated Flange
25	43063	1	Spacer
26	483375	1	Spring, Deck Idler
27	04021-22	12	Locknut, 5/16 - 18 Elastic Stop Gr. 8
28	463435	1	Cutter Deck w/Decals, SZL-42H
29	04041-38	3	Flat Washer, 3/8 - .406 x 2.25 x .1875
30	04001-77	2	Bolt, Hex Head 3/8 - 16 x 3.50"
31	04001-30	1	Bolt, Hex Head 3/8 - 16 x 4.00"
32	04001-175	12	Bolt, Hex Head 5/16 - 18 x 1.50" Gr. 8
33	04003-26	1	Bolt, Carriage 3/8 - 16 x 4.00"
34	481632	1	Wheel, Anti-Scalp
35	04017-27	1	Bolt, Hex Head 3/8 - 16 x 1.00" Serrated Flange
36	04021-05	1	Locknut, 3/8 - 16 Center Lock
37	427865	1	Bracket, Anti-Scalp
38	482295	2	Wheel, Anti-Scalp
39	04117-01	1	Locknut, 5/16 - 18 Flg. HH
40	451926	1	Shaft Weldment
41	04001-09	1	Bolt, Hex Head 5/16 - 18 x 1.00"
42	483014	3	Cutter Blade, 14.75"
43	04043-06	3	Washer, Flat 5/8 - .688 x 1.75 x .134 HD
44	04030-07	3	Lockwasher, 5/8 Spring
45	04001-121	3	Bolt, Hex Head 5/8 - 11x 1.50
46	461950	3	Spindle Assembly
47	43695	3	Shaft, Spindle
48	43694	3	Protector, Bearing
49	483303	6	Bearing, Ball
50	43696	3	Spindle Housing
51	43693	3	Spacer, Bearing
52	463436	1	Idler Arm Assy. (incl. #20)
53	04011-29	2	ScREW, Self Tapping 1/4 - 20

### 48H, 52H & 61H CUTTER DECKS

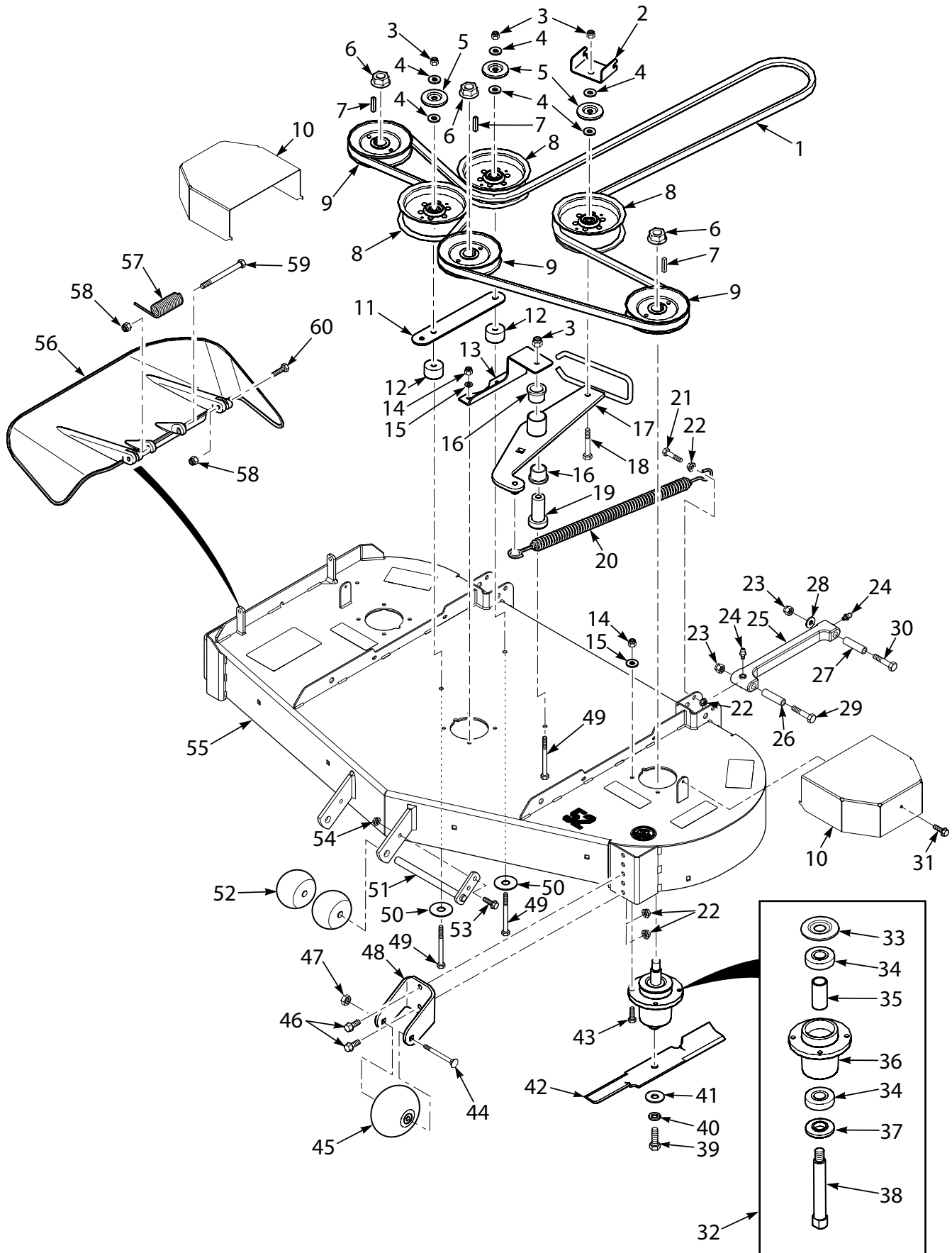



# ILLUSTRATED PARTS LIST

## 48H, 52H & 61H CUTTER DECKS

	Part No.	Qty	Description	48	52	61		Part No.	Qty	Description	48	52	61	
1	485350	1	Belt, Cutter Deck - 48H	x				34	483303	2	Bearing	x	x	x
	485424	1	Belt, Cutter Deck - 52H		x			35	43693	1	Spacer	x	x	x
	486027	1	Belt, Cutter Deck - 61H			x		36	462014	1	Spindle Housing (incl. 34, 35)	x	x	x
2	424615	1	Bracket, Belt Guide	x	x	x		37	43694	1	Protector, Bearing	x	x	x
3	04021-09	4	Nut, 3/8-16 x 16 Elastic Stop	x	x	x		38	43695	1	Shaft, Spindle	x	x	x
4	04043-04	6	Flatwasher, 3/8-.391 x .938 x .105	x	x	x		39	04001-121	3	Bolt, Hex Head 5/8-11 x 1-1/2"	x	x	x
5	424367	3	Dust Shield	x	x	x		40	04030-07	3	Lockwasher, 5/8"	x	x	x
6	04112-06	3	Nut, 3/4-16 Spiral Lock	x	x	x		41	04043-06	3	Flatwasher, 5/8-.688 x 1.75 x .134 HD	x	x	x
7	04063-01	3	Key, 1/4 x 1/4 x 1-1/4"	x	x	x		42	482877	3	Cutter Blade, 16-1/2"	x		
8	483422	3	Pulley, 5" Idler	x	x	x			482878	3	Cutter Blade, 18"		x	
9	483323	3	Pulley, 5.13" OD - 25mm Bore	x					482879	3	Cutter Blade, 21"			x
	483324	3	Pulley, 5.73" OD - 25mm Bore		x			43	04001-175	12	Bolt, Hex Head 5/16-18 x 1-1/2" Gr.8	x	x	x
	484026	3	Pulley, 6.32" OD - 25mm Bore			x		44	04003-26	1	Bolt, Carriage 3/8-16 x 4"	x	x	x
10	426729	2	Belt Cover, SZL	x	x			45	481632	1	Wheel, Anti-Scalp	x	x	x
	425260	2	Belt Cover, SZL61H			x		46	04017-27	2	Bolt, Hex Head Serr. Flange 3/8-16 x 1"	x	x	x
11	424479	1	Brace, Pulley	x	x	x		47	04021-05	1	Nut, 3/8-16 Center Lock	x	x	x
12	43711	2	Spacer	x	x	x		48	427865	1	Bracket, Anti-Scalp	x	x	x
13	424548	1	Support, Idler Pivot - 48H	x				49	04001-77	3	Bolt, Hex Head 3/8-16 x 3-1/2"	x	x	x
	424547	1	Support, Idler Pivot - 52H		x			50	04041-38	2	Flatwasher, 3/8-.406 x 2.250 x .188	x	x	x
	425264	1	Support, Idler Pivot - 61H			x		51	451926	1	Shaft Weldment, Guide Roller	x	x	x
14	04021-22	12	Nut, 5/16-18 Elastic Stop Grade 8	x	x	x		52	482295	2	Wheel, Anti-Scalp	x	x	x
15	04030-03	12	Lockwasher, 5/16"	x	x	x		53	04001-09	1	Bolt, Hex Head 5/16-18 x 1"	x	x	x
16	483453-03	2	Bearing, 1" ID	x	x	x		54	04117-01	1	Nut, 5/16-18 Flange Elastic Stop	x	x	x
17	462037	1	Idler Arm Assembly (incl. 16)	x	x	x		55	463334	1	Cutter Deck w/Decals	x		
18	04001-31	1	Bolt, Hex Head 3/8-16 x 2-1/2"	x	x	x			463335	1	Cutter Deck w/Decals		x	
19	43708	1	Pivot, Idler	x	x	x			463336	1	Cutter Deck w/Decals			x
20	483375	1	Spring, Cutter Deck Idler	x	x	x		56	462031	1	Discharge Chute	x		
21	04001-136	1	Bolt, Hex Head 3/8-16 x 1-1/2" Gr.8	x	x	x			462032	1	Discharge Chute		x	
22	04019-04	4	Nut, 3/8-16 Serrated Flange	x	x	x			462213	1	Discharge Chute			x
23	04021-07	4	Nut, 1/2-13 Elastic Stop	x	x	x		57	482245	1	Spring, Discharge Chute	x	x	x
24	48114-04	4	Grease Fitting, 1/4-28 Self Tap	x	x	x		58	04021-10	3	Nut, 5/16-18 Elastic Stop	x	x	x
25	462769	1	Pusharm Assembly, LH (incl. 24)	x	x	x		59	04001-154	1	Bolt, Hex Head 5/16-18 x 4-3/4"	x	x	x
	462770	1	Pusharm Assembly, RH (incl. 24)	x	x	x		60	04001-12	2	Bolt, Hex Head 5/16-18 x 1-3/4"	x	x	x
26	43985	2	Spacer, Pusharm - Deck	x	x	x								
27	43986	2	Spacer, Pusharm - Axle	x	x	x								
28	04040-07	2	Flatwasher, 1/2-.531 x 1.062 x .095	x	x	x								
29	04001-145	2	Bolt, Hex Head 1/2-13 x 3-1/2"	x	x	x								
30	04001-52	2	Bolt, Hex Head 1/2-13 x 2-1/2"	x	x	x								
31	04011-29	2	Screw, 1/4-20 x .375"	x	x									
	04013-05	4	Screw, 3/8-16 x 3/4"			x								
32	461950	3	Spindle Assembly	x	x	x								
33	483304	1	Debris Shield	x	x	x								

## 36H & 42H CUTTER DECK CONTROLS

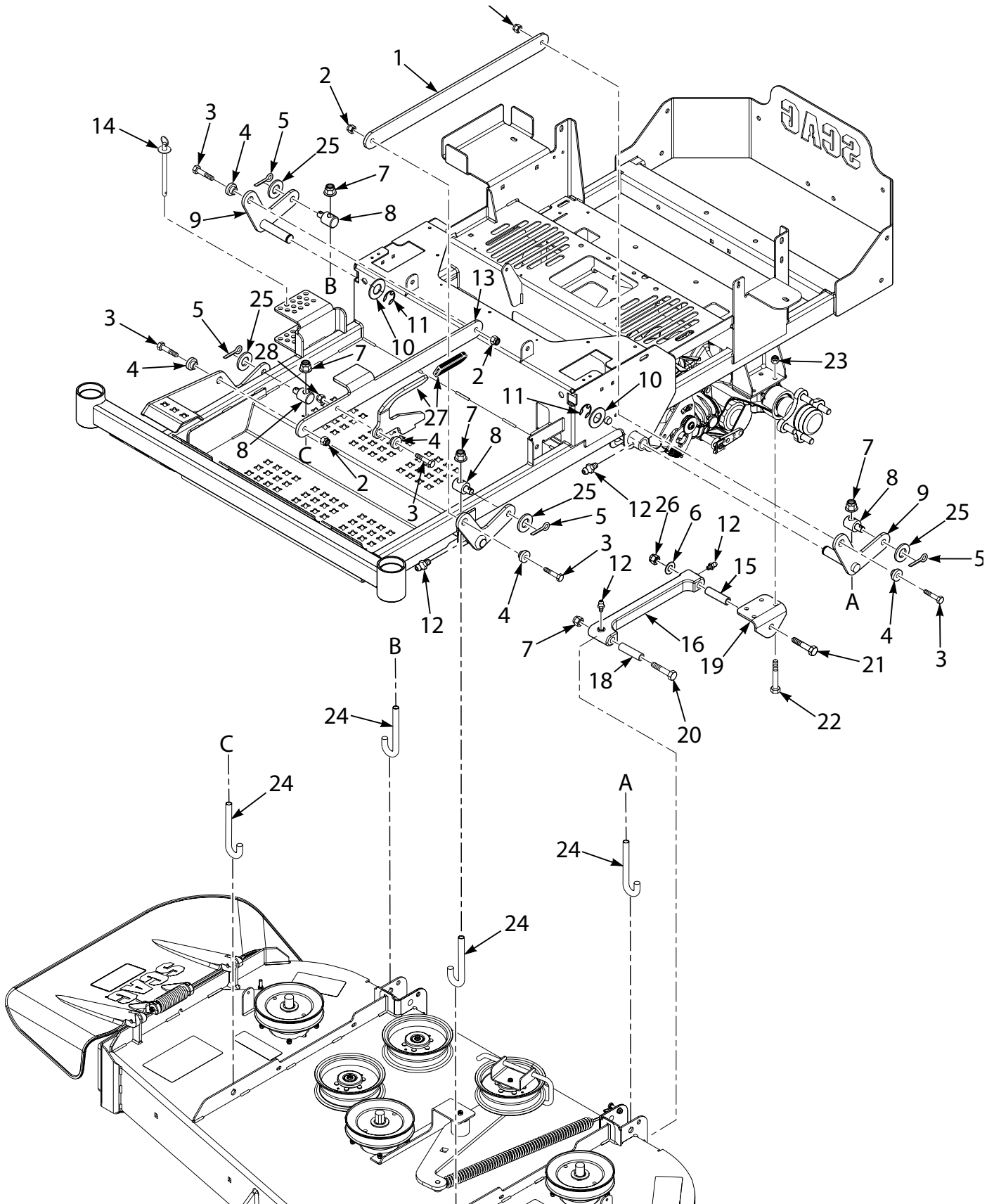

36H & 42H CUTTER DECK CONTROLS

Ref. No.	Part No.	Qty	Description
1	428142	1	Link, Deck Lift - LH
2	04117-02	4	Nut, 3/8-16 Elastic Stop
3	04001-32	4	Bolt, Hex Head 3/8-16 x 1-1/4"
4	43086	4	Bushing
5	04061-07	4	Cotter Pin, 3/16 x 1"
6	04040-07	6	Flatwasher, 1/2-.531 x 1.062 x .095
7	04021-07	4	Nut, 1/2-13 Elastic Stop
8	431072	4	Joint, Swivel
9	452962	2	Lift Bellcrank Weldment
10	04041-08	2	Flatwasher, 3/4-.769 x 1.250 x .0598
11	04050-02	2	Retaining Ring, .750 "E"
12	48114-04	4	Grease Fitting, 1/4-28 Self Tap
13	428143	1	Link, Deck Lift - RH
14	485351	1	Pin Assembly, Deck Height
15	431087	6	Bushing, Deck latch
16	04117-04	6	Nut, 1/2-13 Elastic Stop
17	44220	6	Rod, Deck lift
18	04001-183	4	Bolt, Hex Head 1/2-13 x 1-3/4
19	427302	2	Pull Arm, Deck
20	427303	1	Lateral Link
21	04040-09	4	Flatwasher, 5/18 - .656 x 1.312 x .095
22	04021-09	1	Nut, 3/8-16 Elastic Stop
23	462887	1	Lever Assembly (incl. Grip)
	485718	1	Grip

### 48H, 52H & 61H CUTTER DECK CONTROLS

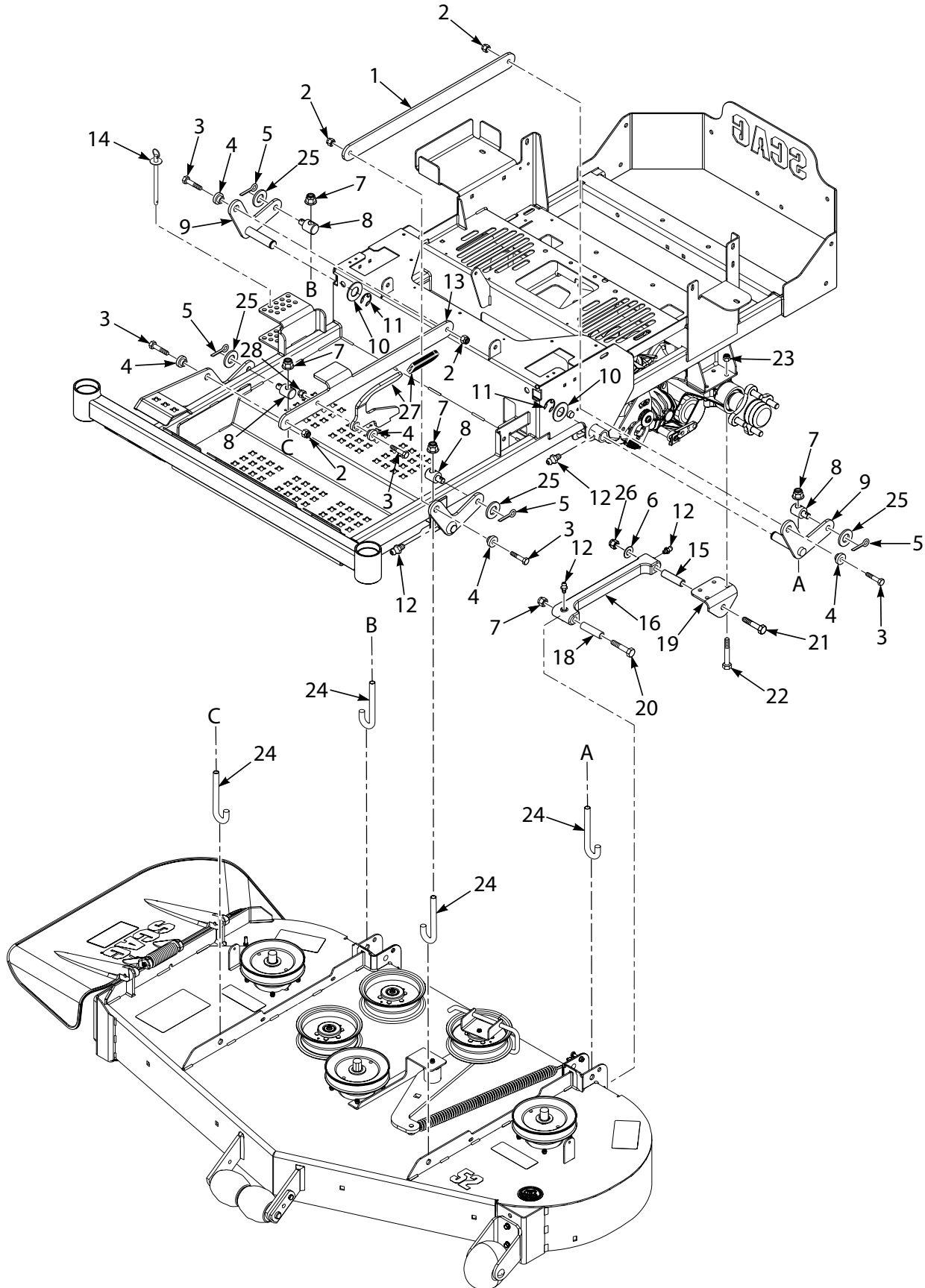

**48H, 52H & 61H CUTTER DECK CONTROLS**

Ref. No.	Part No.	Qty	Description
1	428142	1	Link, Deck Lift - LH
2	04117-02	4	Nut, 3/8-16 Elastic Stop
3	04001-32	4	Bolt, Hex Head 3/8-16 x 1-1/4"
4	43086	4	Bushing
5	04061-07	4	Cotter Pin, 3/16 x 1"
6	04040-07	2	Flatwasher, 1/2-.531 x 1.062 x .095
7	04021-07	6	Nut, 1/2-13 Elastic Stop
8	431072	4	Joint, Swivel
9	452962	2	Lift Bellcrank Weldment
10	04041-08	2	Flatwasher, 3/4-.769 x 1.250 x .0598
11	04050-02	2	Retaining Ring, .750 "E"
12	48114-04	8	Grease Fitting, 1/4-28 Self Tap
13	428143	1	Link, Deck Lift - RH
14	485351	1	Pin Assembly, Deck Height
15	43986	2	Spacer, Pusharm - Axle
16	462769	1	Pusharm Assembly, LH (incl. 12)
17	462770	1	Pusharm Assembly, RH (incl. 12)
18	43985	2	Spacer, Pusharm - Deck
19	424489	2	Bracket, Pusharm
20	04001-145	2	Bolt, Hex Head 1/2-13 x 3-1/2"
21	04001-52	2	Bolt, Hex Head 1/2-13 x 2-1/2"
22	04001-49	8	Bolt, Hex Head 5/16-18 x 3"
23	04021-10	8	Nut, 5/16-18 Elastic Stop
24	44220	4	Rod, Deck Lift
25	04040-09	4	Washer, Flat, 5/8 - .656 x 1.312 x .095
26	04021-19	2	Nut, 1/2-13 Center Lock
27	462887	1	Lever Assembly (incl. Grip)
	485718	1	Grip
28	04021-09	1	Nut, 3/8-16 Elastic Stop

### 36H & 42H SHEET METAL COMPONENTS

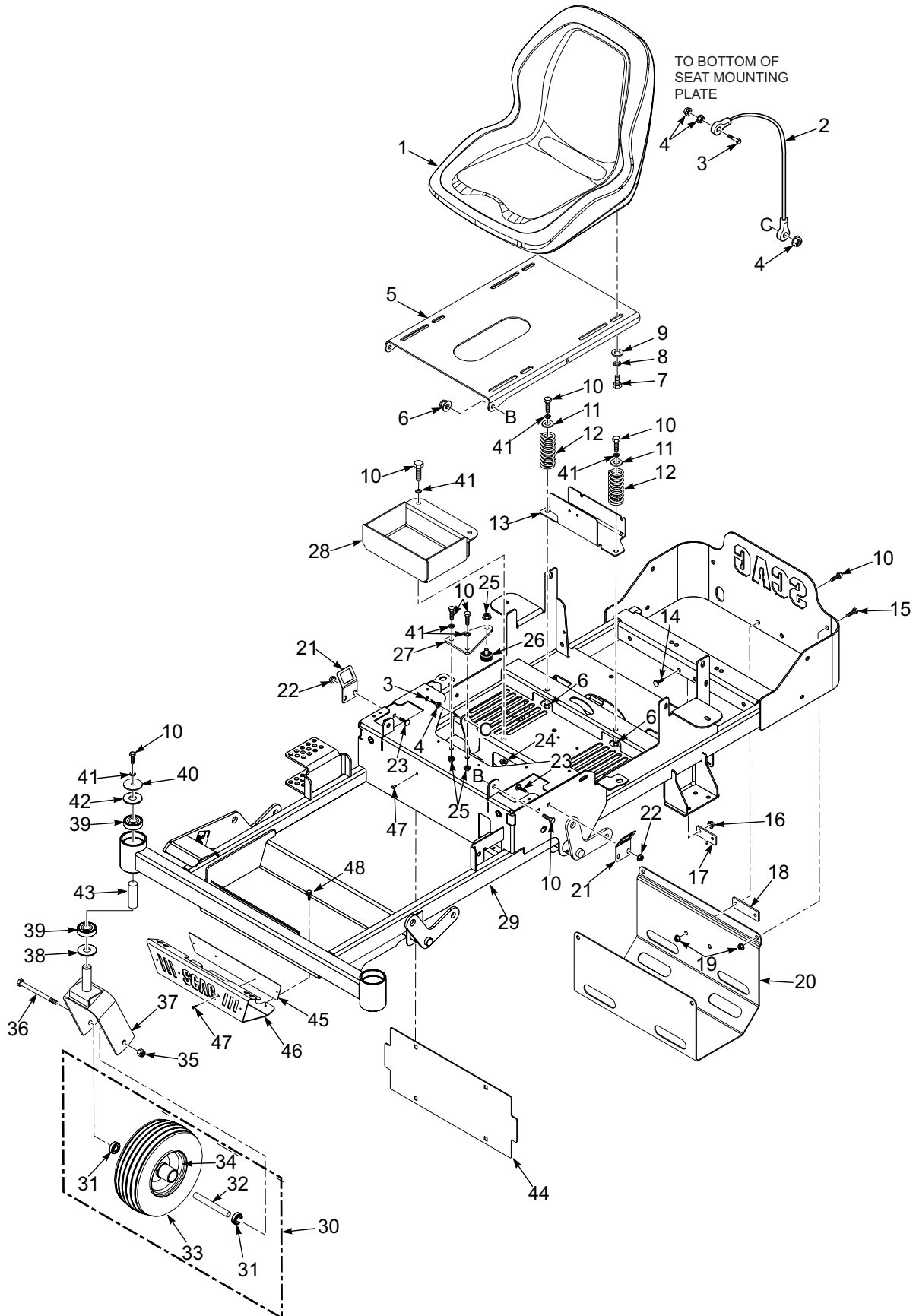

36H & 42H SHEET METAL COMPONENTS

Ref. No.	Part No.	Qty	Description
1	486499	1	Seat, SZL
2	483559	1	Cable, Seat Stop
3	04001-59	2	Bolt, Hex Head 1/4-20 x 1-1/4"
4	04019-02	4	Nut, 1/4-20 Serrated Flange
5	463384	1	Seat-Plate W/Decal
6	04117-02	2	Nut, Flanged Elastic Stop, 3/8-16
7	04001-09	4	Bolt, Hex Head 5/16-18 x 1"
8	04030-03	4	Lockwasher, 5/16"
9	04040-15	4	Flatwasher, 5/16-.375 x .875 x .083
10	04001-19	10	Bolt, Hex Head 3/8-16 x 1"
11	04041-07	2	Flatwasher, 3/8-.391 x .938 x .105
12	483372	2	Spring, Seat
13	427341	1	Seat Stop
14	04003-12	2	Bolt, Carriage 5/16-18 x 3/4"
15	04001-18	4	Bolt, Hex Head 3/8-16 x 3/4"
16	04117-01	2	Nut, 5/16-18 Elastic Stop
17	427961	1	Plate, Anti-Rotation
18	428187	1	Plate, Spacer
19	04019-04	6	Nut, 3/8-16 Serrated Flange
20	428131	1	Skid Plate, SZL-36
21	426727	2	Bracket, Switch
22	04117-03	4	Nut, 1/4-20 Flange Elastic Stop
23	04003-02	4	Bolt, Carriage 1/4-20 x 3/4"
24	04132-01	2	Threaded Insert, 3/8-16
25	04132-01	3	Threaded Insert, 3/8-16
26	481284	1	Bumper, Rubber
27	428183	1	Battery Hold Down
28	428186	1	Battery Box
29	463349	1	Frame Assembly, SZL-36H & SZL42H
30	485207	2	Caster Wheel Assembly (incl. 31, 32, 33, 34)
31	485243	4	Bearing
32	43974	2	Spacer, Wheel Bearings
33	483417	2	Tire, 11 x 4 x 5
34	485242	2	Rim Assembly (incl. 31, 32)
35	04021-07	2	Nut, 1/2-13 Elastic Stop
36	04001-80	2	Bolt, Hex Head 1/2-13 x 6-1/2"
37	463183	2	Caster Assembly (INCL 30,35,36)
	453060	2	Yoke Weldment, Caster
38	424636	2	Spacer, Yoke
39	483466	4	Bearing
40	04041-38	2	Flatwasher, 3/8-.406 x 2.25 x .188
41	04030-04	8	Lockwasher, 3/8"
42	04040-11	2	Flatwasher, 7/16-.500 x 1.25 x .83
43	43736	2	Spacer, Caster Bearing
44	428141	1	Plate, Backing
45	427875	1	Plate, Decal
46	427868	1	Bumper, Front
47	04090-03	6	Pop, Rivet 3/16 x .402
48	04011-29	4	Screw, 1/4-20 x .375 Shakeproof

### 48H, 52H & 61H SHEET METAL COMPONENTS

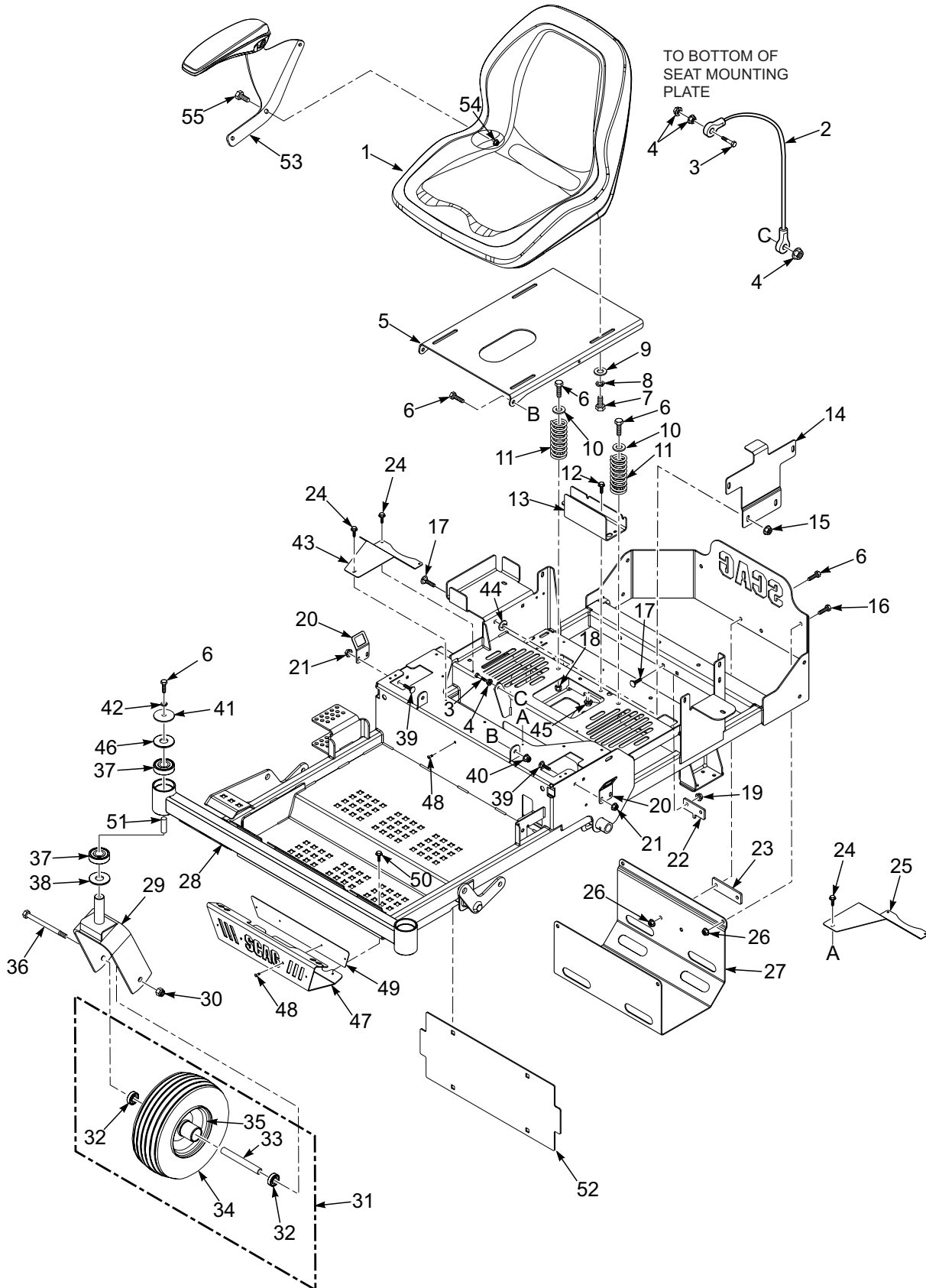



48H, 52H & 61H SHEET METAL COMPONENTS

	Part No.	Qty	Description
1	486602	1	Seat, SZL w/Armrests
	486633	1	Armrest, RH (48H, 52H, 61H)
	486634	1	Armrest, LH (48H, 52H, 61H)
2	483559	1	Cable, Seat Stop
3	04001-59	2	Bolt, Hex Head 1/4-20 x 1-1/4"
4	04019-02	4	Nut, 1/4-20 Serrated Flange
5	463384	1	Seat Plate w/Decal
6	04001-19	8	Bolt, Hex Head 3/8-16 x 1"
7	04001-09	4	Bolt, Hex Head 5/16-18 x 1"
8	04030-03	4	Lockwasher, 5/16"
9	04040-15	4	Flatwasher, 5/16-.375 x .875 x .083
10	04041-07	2	Flatwasher, 3/8-.391 x .938 x .105
11	483372	2	Spring, Seat
12	04017-16	2	Bolt, Hex Head 5/16-18 x 3/4" Serrated Flange
13	426768	1	Channel, Hose
14	428184	1	Battery Hold Down
15	04117-01	2	Nut, 5/16-18 Flange Elastic Stop
16	04001-18	4	Bolt, Hex Head 3/8-16 x 3/4"
17	04003-12	4	Bolt, Carriage 5/16-18 x 3/4"
18	04021-09	2	Nut, 3/8-16 Elastic Stop
19	04117-01	2	Nut, 5/16-18 Flange Elastic Stop
20	426727	2	Bracket, Switch
21	04117-03	4	Nut, 1/4-20 Flange Elastic Stop
22	427961	1	Plate, Anti-Rotation
	428752	1	Plate, Anti-Rotation - Warner (SZL-48)
23	428187	1	Plate, Spacer
24	04011-11	6	Screw, #10-32 x .56
25	426767	1	Guard, Belt - LH
26	04019-04	6	Nut, 3/8-16 Serrated Flange
27	428132	1	Skid Plate, SZL
28	463421	1	Mainframe w/Decals - SZL48H/52H
	463422	1	Mainframe w/Decals - SZL61H
29	463184	2	Caster Assembly (INCL 30,31,36)
	453010	2	Yoke Weldment, Caster
30	04021-07	2	Nut, 1/2-13 Elastic Stop

	Part No.	Qty	Description
	31	2	Caster Wheel Assembly (incl. 32, 33, 34, 35)
	32		Bearing
	33	4	Spacer, Wheel Bearing
	34	1	Tire, 11 x 6 x 5
	35	1	Rim Assembly (incl. 32, 33)
	36	1	Bolt, Hex Head 1/2-13 x 6-1/2"
	37	2	Bearing
	38	4	Spacer, Yoke
	39	2	Bolt, Carriage 1/4-20 x 3/4"
	40	4	Nut, 3/8-16 Flange Elastic Stop
	41	2	Flatwasher, 3/8-.406 x 2.25 x .188
	42	2	Lockwasher, 3/8"
	43	2	Guard, Belt - RH
	44	1	U-Nut, 5/16 Push-On
	45	2	Nut, 5/16-18 Serrated Flange
	46	2	Flatwasher, 7/16-.500 x 1.25 x .83
	47	2	Bumper, Front
	48	1	Rivet, 3/16 x .402
	49	4	Plate, Decal
	50	1	Screw, 1/4-20 x .375
	51	4	Spacer, Caster Bearing
	52	2	Plate, Backing
	53	1	Armrest, SZL LH
		1	Armrest, SZL RH
	54		U-nut, 1/4-14
	55	6	Screw, Self Tapping 1/4-14 x 1"
	56	6	Bolt, Carriage 5/16-18 x 3/4"
	57	7	Mounting Weldment, Axle - Tuff Torq
		1	Mounting Weldment, Axle - Hydro-Gear

### 36H & 42H DRIVE SYSTEM COMPONENTS - HYDRO-GEAR AXLES

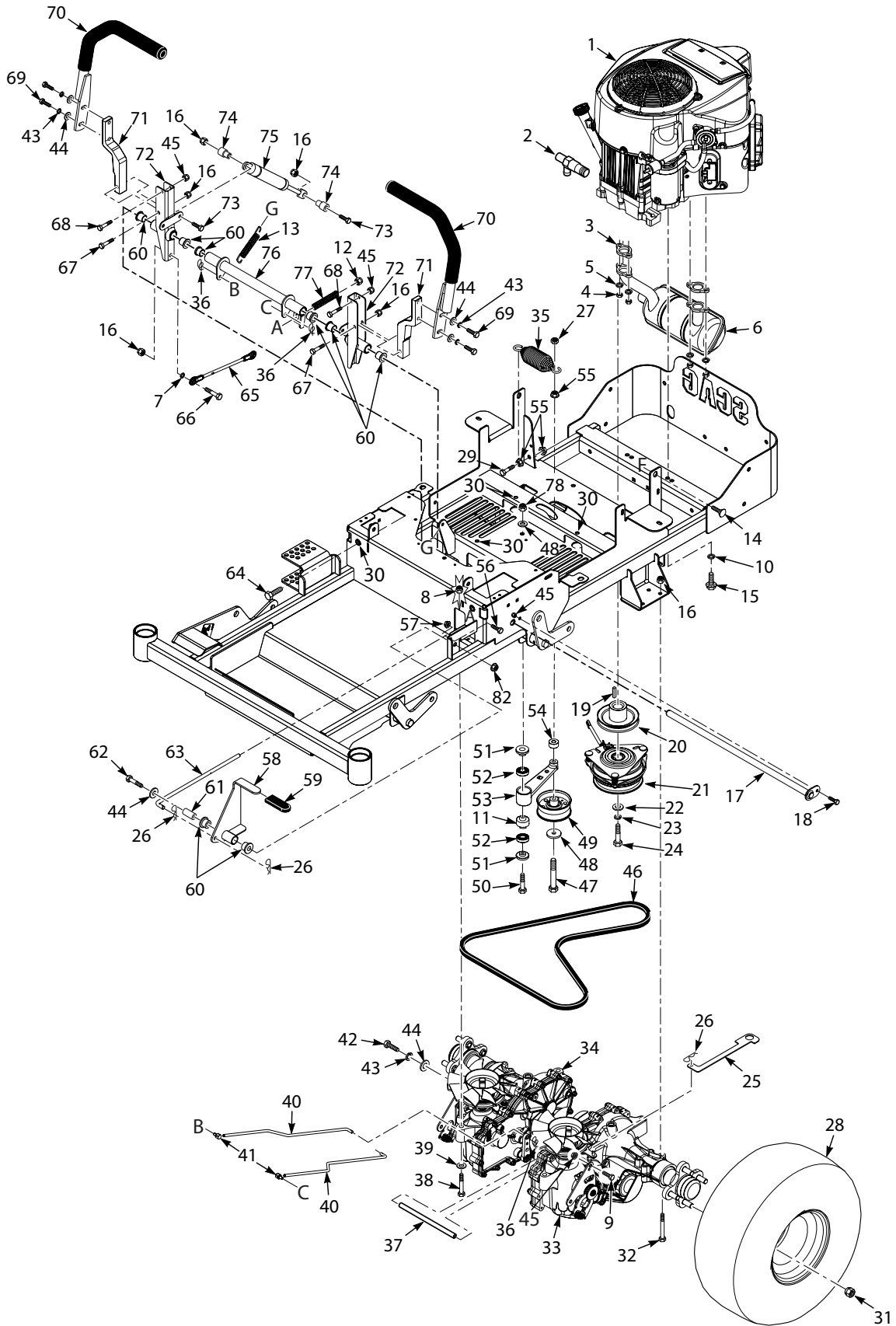

# ILLUSTRATED PARTS LIST

## 36H & 42H DRIVE SYSTEM COMPONENTS - HYDRO-GEAR AXLES

	Part No.	Qty	Description		Part No.	Qty	Description
1	*485192	1	Engine, Kawasaki - FR600V (INCL. 3,4,5)	46	485808	1	Belt, Transmission SZL-36/42
	*487153	1	Engine, Briggs & Stratton PXi2000	47	04001-51	1	Bolt, Hex Head 3/8-16 x 3-3/4"
	*487203	1	Engine, Briggs & Stratton PXi2200	48	04043-04	2	Flatwasher, 3/8-.391 x .938 x .105
	*485219	1	Engine, Kawasaki - FR651V (INCL. 3,4,5)	49	486045	1	Pulley, 3-1/2" Idler
2	*	1	Oil Drain, Kawasaki	50	04001-54	1	Bolt, Hex Head 3/8-16 x 3"
3	484210	2	Gasket, Exhaust	51	431049	2	Pivot Idler
4	04025-04	4	Nut, M8 x 1.25 Hex Special	52	48224	2	Bearing
5	04033-01	4	Lockwasher, M8 Metric Spring	53	463017	1	Idler Arm Assembly (incl. 52, 83)
6	485193	1	Muffler, Kawasaki FR600V	54	43720	1	Spacer, Idler Arm
	487151	1	Muffler, Briggs & Stratton PXi	55	04019-04	4	Nut, 3/8-16 Serrated Flange
	485225	1	Muffler, Kawasaki FR651V	56	04001-11	1	Bolt, Hex Head 5/16-18
7	04030-03	2	Washer, Lock 5/16 Spring	57	04117-02	1	Nut, 3/8-16 Flange Elastic Stop
8	04117-01	4	Nut, 5/16-18 Flanged Elastic Stop	58	463186	1	Brake Lever Assembly (INCL 59,60)
9	04001-04	2	Bolt, Hex Head, 1/4-20 x 1 1/2"	59	482102	1	Grip, Brake Handle
10	04030-04	4	Washer, Lock 3/8 Spring	60	483453-05	8	Bearing
	04031-03	1	Washer, Lock 5/16 Ext Tooth (ground)	61	43969	1	Pivot, Brake Lever
11	431073	1	Spacer, Idler Arm	62	04001-31	1	Bolt, Hex Head 3/8-16 x 2-1/2"
12	04117-02	1	Nut, 3/8-16 Flange Elastic Stop	63	44231	1	Rod, Upper Brake Linkage
13	483600	1	Spring, Brake Return	64	04107-08	2	Bolt, Hex Head 3/8-16 x 3.0
14	04003-02	2	Bolt, Carriage 1/4-20 x 3/4"	65	485794	2	Linkage Assembly, Steering
15	04001-32	4	Bolt, Hex Head 3/8-16 x 1 1/4"	66	04001-10	2	Bolt, Hex Head 5/16-18 x 1-1/4
16	04021-10	14	Nut, 5/16-18 Elastic Stop	67	04001-12	2	Bolt, Hex Head 5/16-18 x 1-3/4"
17	452847	1	Shaft Weldment, Control Arm	68	04001-02	2	Bolt, Hex Head 1/4-20 x 1-3/4"
18	04001-06	1	Bolt, Hex Head 1/4-20 x 5/8"	69	04001-19	4	Bolt, Hex Head 3/8-16 x 1"
19	04063-01	1	Key, 1/4 x 1/4 x 1-1/4"	70	463163	2	Handlebar W/ Grip, SZL-36
20	485956	1	Pulley, 4-1/2" - 1" Bore	71	485835	2	Lever, Control Arm
21	462715	1	Clutch, GT1- 1" Bore	72	462941	2	Control Arm Weldment, SZL-36 (INCL 60)
22	04041-28	1	Flatwasher, 7/16-.496 x 1.75 x .25	73	04001-17	4	Bolt, Hex Head 5/16-18 x 1-1/2"
23	04030-05	1	Lockwasher, 7/16"	74	43833	4	Spacer, Pump Dampener
24	04102-12	1	Bolt, 7/16-20 x 3-1/4" w/Patch	75	484193	2	Dampener
25	427283	2	Lever, Dump Valve	76	463023	1	Bellcrank Assembly, Brake (INCL 60)
26	04062-02	4	Hair Pin Cotter, .080 x 1.19	77	483538	1	Spring, Brake
27	04021-05	1	Nut, 3/8-16 Center Lock	78	04021-09	2	Nut, 3/8-16 x 16 Elastic Stop
28	485801	2	Wheel Assembly, 20 x 8.0-10 (36H)				
	485802	2	Rim W/Valve Stem 10 x 5.0 (36H)				
	485803	2	Tire, 20 x 8.0-10 (36H)				
	485948	2	Wheel Assembly, 20 x 10-10 (42H)				
	485949	2	Rim W/Valve Stem 10 x 7.0 (42H)				
	485950	2	Tire, 20 x 10-10 (42H)				
29	04001-136	1	Bolt, Hex Head 3/8-16 x 1-1/2"				
30	04132-01	8	Threaded insert, Hex Head (Pressed)				
31	04028-02	8	Wheel Nut, 1/2-20 x 13/16				
32	04001-13	8	Bolt, Hex Head 3/8-16 x 1-1/2"				
33	486787	1	Transaxle, LH- ZT-2800				
34	486788	1	Transaxle, RH- ZT2800				
35	483112	1	Spring, Transmission Drive				
36	04069-01	4	Pin, Rue Cotter - 3/8"				
37	431039	1	Spacer, Axle				
38	04001-39	4	Bolt, Hex Head 5/16-18 x 2-1/4				
39	04040-15	4	Flatwasher, 5/16-.375 x .875 x .083				
40	44225	2	Rod, Brake				
41	43876	2	Joint, Swivel				
42	04001-46	2	Bolt, Hex Head 1/4-20 x 1-1/2				
43	04030-04	6	Lockwasher, 3/8"				
44	04041-07	7	Flatwasher, 3/8-.391 x .938 x .105				
45	04021-08	5	Nut, 1/4-20 Elastic Stop Nut				

\* Available through individual engine manufacturer.

### 48H, 52H & 61H DRIVE SYSTEM COMPONENTS - TUFF TORQ AXLES

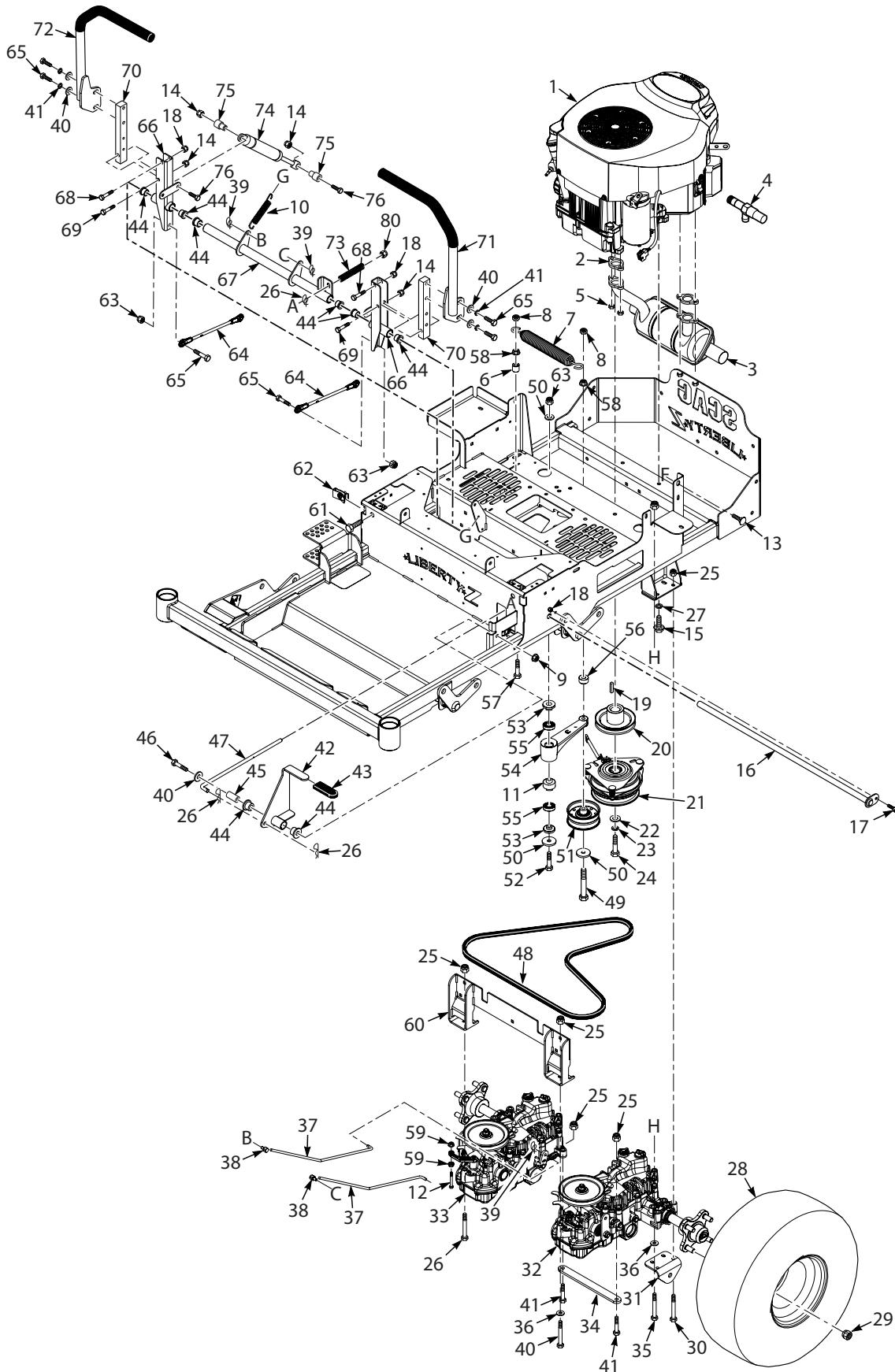

# ILLUSTRATED PARTS LIST

## 48, 52H & 61H DRIVE SYSTEM COMPONENTS - TUFF TORQ AXLES

	Part No.	Qty	Description		Part No.	Qty	Description
1	*485219	1	Engine, Kawasaki - FR651V	29	04028-02	8	Wheel Nut, 1/2-20 x 13/16
	*487203	1	Engine, Briggs & Stratton PXi2200	30	04001-49	8	Bolt, Hex Head 5/16-18 x 3"
	463477	1	Engine, Scag	31	428348	2	Bracket, Pusharm
	*485971	1	Engine, Kohler - 22KT	32	486650	1	Transaxle - Tuff Torq, LH - SZL
	*485972	1	Engine, Kohler - 24KT	33	486651	1	Transaxle - Tuff Torq, RH - SZL
	*487204	1	Engine, Briggs & Stratton PXi2400	34	428891	1	Stiffener, Axle
	*485220	1	Engine, Kawasaki - FR691V	35	04001-39	4	Bolt, Hex Head 5/16-18 x 2-1/4"
	*487205	1	Engine, Briggs & Stratton PXi2500	36	04040-15	6	Flatwasher, 5/16-.375 x .875 x .083
	*486809	1	Engine, Kawasaki - FR730V	37	44244	1	Rod, Brake - LH
	*486021	1	Engine, Kohler - 26KT		44245	1	Rod, Brake - RH
	487173	1	Engine, Scag LC2P82F	38	43876	2	Joint, Swivel
2		2	Gasket, Exhaust	39	04069-01	4	Pin, Rue Cotter - 3/8"
3	485225	1	Muffler, Kawasaki FR651V	40	04001-39	1	Bolt, Hex Head 5/16-18 x 2-1/4"
	487151	1	Muffler, Briggs & Stratton PXi	41	04001-21	2	Bolt, Hex Head 3/8-16 x 1-3/4"
	487170	1	Muffler, Scag LC2P77F/82F	42	463187	1	Brake Lever Assembly (incl. 43, 44)
	485336	1	Muffler, Kohler	43	482102	1	Grip, Brake Handle
4	*	1	Oil Drain, Kawasaki	44	483453-05	8	Bearing
	482510	1	Oil Drain, Hose Assy.	45	43969	1	Pivot, Brake Lever
5	04025-04	4	Nut, M8-1.25 Hex Flange	46	04001-31	1	Bolt, Hex Head 3/8-16 x 2-1/2"
6	43674	1	Spacer	47	44231	1	Rod, Upper Brake Linkage
7	483112	1	Spring, Transmission Drive	48	486649	1	Belt, Tuff Torq Transmission-SZL
8	04021-05	2	Nut, 3/8-16 Center Lock	49	04001-51	1	Bolt, Hex Head 3/8-16 x 3-3/4"
9	04117-02	2	Nut, 3/8-16 Flange Elastic Stop	50	04043-04	3	Flatwasher, 3/8-.391 x .938 x .105 HD
10	483600	1	Spring, Brake Return	51	486045	1	Pulley, 3-1/2" Idler
11	431073	1	Spacer, Idler Arm	52	04001-54	1	Bolt, Hex Head 3/8-16 x 3"
12	04001-46	2	Bolt, 3/8-16 x 2 1/4"	53	431049	2	Pivot Idler
13	04003-02	2	Bolt, Carriage 1/4-20 x 3/4"	54	463017	1	Idler Arm Assembly (incl. 55, 84)
14	04021-10	18	Nut, 5/16-18 Elastic Stop	55	48224	2	Bearing
15	04001-32	4	Bolt, 3/8-16 x 1-1/4"	56	43720	1	Spacer, Pump Idler
16	452620	1	Shaft Weldment, Control Arm	57	04001-45	1	Bolt, Hex Head 3/8-16 x 2"
17	04001-06	1	Bolt, Hex Head 1/4-20 x 5/8"	58	04019-04	2	Nut, 3/8-16 Serrated Flange
18	04021-08	3	Nut, 1/4-20 Elastic Stop	59	04019-02	4	Nut, 1/4-20 Serrated Flange
19	04063-01	1	Key, 1/4 x 1/4 x 1-1/4" (48H, 52H)	60	453255	1	Mounting Weldment, Tuff Torq Axle - Front
	04063-42	1	Key, 1/4 x 1/4 x 3" (61H)	61	04107-05	2	Bolt, Hex Head 3/8-16 x 2-1/2" Special Lock
20	487032	1	Pulley, 4-1/2" - 1" Bore	62	04110-04	2	U-Nut, 3/8-16
	487394	1	Pulley, 4-1/4" - 1-1/8" Bore (61H)	63	04021-09	6	Nut, 3/8-16 Elastic Stop
21	487077	1	Clutch	64	486691	2	Linkage, Pump
	462228	1	Clutch, GT2 (61H)	65	04001-32	8	Bolt, Hex Head 3/8-16 x 1-1/4"
22	04030-05	1	Flatwasher, 7/16-.496 x 1.75 x .25	66	462797	2	Control Arm Assembly (incl. 44)
23	04102-12	1	Lockwasher, 7/16"	67	463019	1	Bellcrank Assembly (incl. 44)
24	04102-12	1	Bolt, 7/16-20 x 3 1/4" w/Patch	68	04001-02	2	Bolt, Hex Head 1/4-20 x 1-3/4"
	04102-03	1	Bolt, 7/16-20 x 2 1/4" w/Patch (61H)	69	04001-12	2	Bolt, Hex Head 5/16-18 x 1-3/4"
25	04117-01	12	Nut, 5/16-18 Flange Elastic Stop	70	422372	2	Bar, Control Lever
26	04001-39	1	Bolt, Hex Head 5/16-18 x 2-1/4"	71	462740	1	Handlebar w/Grip
27	04030-04	4	Washer, Lock 3/8 Spring		484376	1	Grip, Control Lever
	04031-03	1	Washer, Lock 5/16 Ext Tooth (ground)	72	462741	1	Handlebar w/Grip
28	483390	2	Wheel Assembly		484376	1	Grip, Control Lever
	481868	1	Rim w/Valve Stem	73	483538	1	Spring, Brake
	483389	1	Tire, 20 x 10-8	74	484193	2	Dampener, Steering
	485948	1	Wheel Assembly (61H)	75	43602	4	Spacer, Damper
	485949	1	Rim w/Valve Stem (61H)	76	04001-11	4	Bolt, Hex Head 5/16-18
	485948	1	Tire, 20 x 10-10 (61H)				

\* Available through individual engine manufacturer.

## 36 & 42 ELECTRICAL SYSTEM

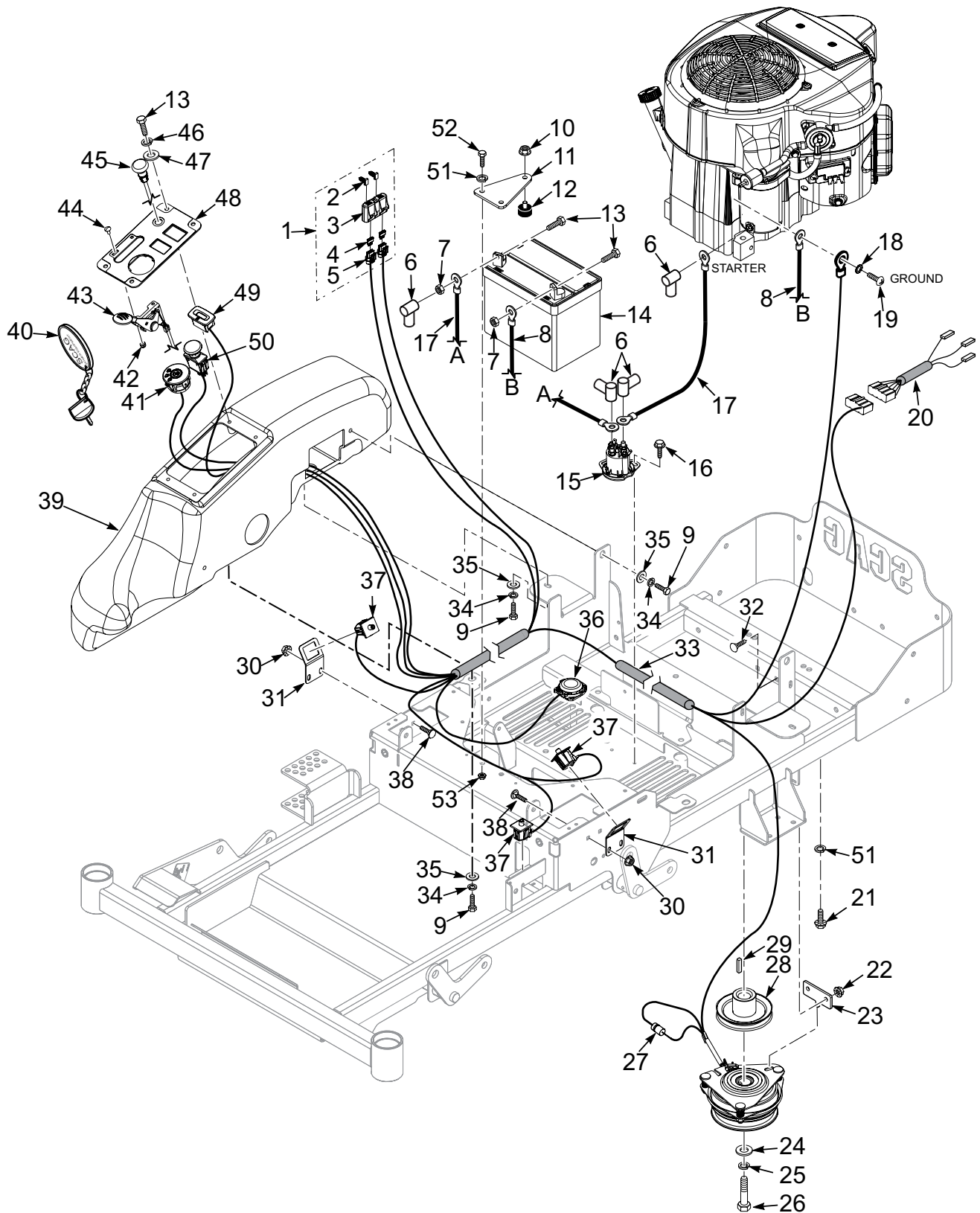

# ILLUSTRATED PARTS LIST

## 36 & 42 ELECTRICAL SYSTEM

Ref. No.	Part No.	Qty	Description
1	483642	1	Double Fuse Assembly (incl. 2, 3, 4, 5)
2	482588	2	Clip, Wire
3	483571	1	Cover, Double
4	48298	2	Fuse, 20 Amp
5	483629	2	Fuse Holder
6	48126	4	Rubber Boot
7	04020-02	2	Nut, 1/4-20 UNC
8	48029-14	1	Battery Cable, Black 31.50
9	04001-08	4	Bolt, Hex Head 5/16-18 x 3/4"
10	04019-03	1	Nut, 5/16-18 Serrated Flange
11	428183	1	Battery Hold Down
12	481284	1	Bumper, Rubber
13	04001-44	6	Bolt, Hex Head 1/4-20 x 1/2"
14	485212*	1	Battery, 12v - 230CCA
15	483278	1	Solenoid, Sealed
16	04011-14	2	Screw, Self-Tapping 1/4-20 x 3/4
17	48029-29	2	Battery Cable, Red 18.0 w/Braid
18	04031-03	1	Lockwasher, 5/16" Ext.
19	04002-06	1	Bolt, Hex Head M8 x 1-1/4 x 16
20	483529	1	Wire Harness Adapter, Kawasaki
21	04001-32	4	Bolt, Hex Head 3/8-16 x 1 1/4"
22	04117-01	2	Nut, 5/16-18 Flange Elastic Stop
23	427961	1	Plate, Anti-Rotation
24	04041-28	1	Flatwasher, 7/16-.496 x 1.75 x .25
25	04030-05	1	Lockwasher, 7/16"
26	04102-12	1	Bolt, 7/16-20 x 3 1/4" w/Patch
27	483958	1	Diode, 600V 6 Amp
28	485956	1	Pulley, 4-1/2" - 1" Bore
29	04063-01	1	Key, 1/4 x 1/4 x 1-1/4"
30	04117-03	4	Nut, 1/4-20 Flange Elastic Stop
31	426727	2	Bracket, Switch
32	04003-12	2	Bolt, Carriage 5/16-18 x 3/4"
33	486518	1	Wire Harness
34	04030-03	4	Lockwasher, 5/16"
35	04040-15	4	Flatwasher, 5/16-.375 x .875 x .083
36	483474	1	Switch, Double Pole - Twist
37	483473	3	Switch, Double Pole - Plunger
38	04003-02	4	Bolt, Carriage 1/4-20 x 3/4"
39	463189	1	Console Tank w/Decals, SZL-36
40	462069	1	Key Fob Assembly
41	483472	1	Ignition Switch
42	04021-26	2	Nut, #10-24 Elastic Stop
43	483645	1	Throttle Control, Kawasaki / Briggs & Stratton
44	04003-43	2	Bolt, Carriage #10-24 x 1/2"
45	483646	1	Choke Control, Kawasaki / Briggs & Stratton
46	04030-02	4	Lockwasher, 1/4"
47	04040-14	4	Flatwasher, 1/4-.312 x .750 x .065
48	462942	1	Instrument Panel w/Decal, SZL-36
49	484565	1	Hourmeter, Inductive
50	485833	1	Switch, PTO
51	04030-04	6	Washer, Lock 3/8 Spring
52	04001-19	2	Bolt, Hex Head 3/8-16 x 1"
53	04132-01	2	Threaded Insert, 3/8-16

\* Not available through Scag Power Equipment. Purchase locally.

### 48, 52 & 61 ELECTRICAL SYSTEM

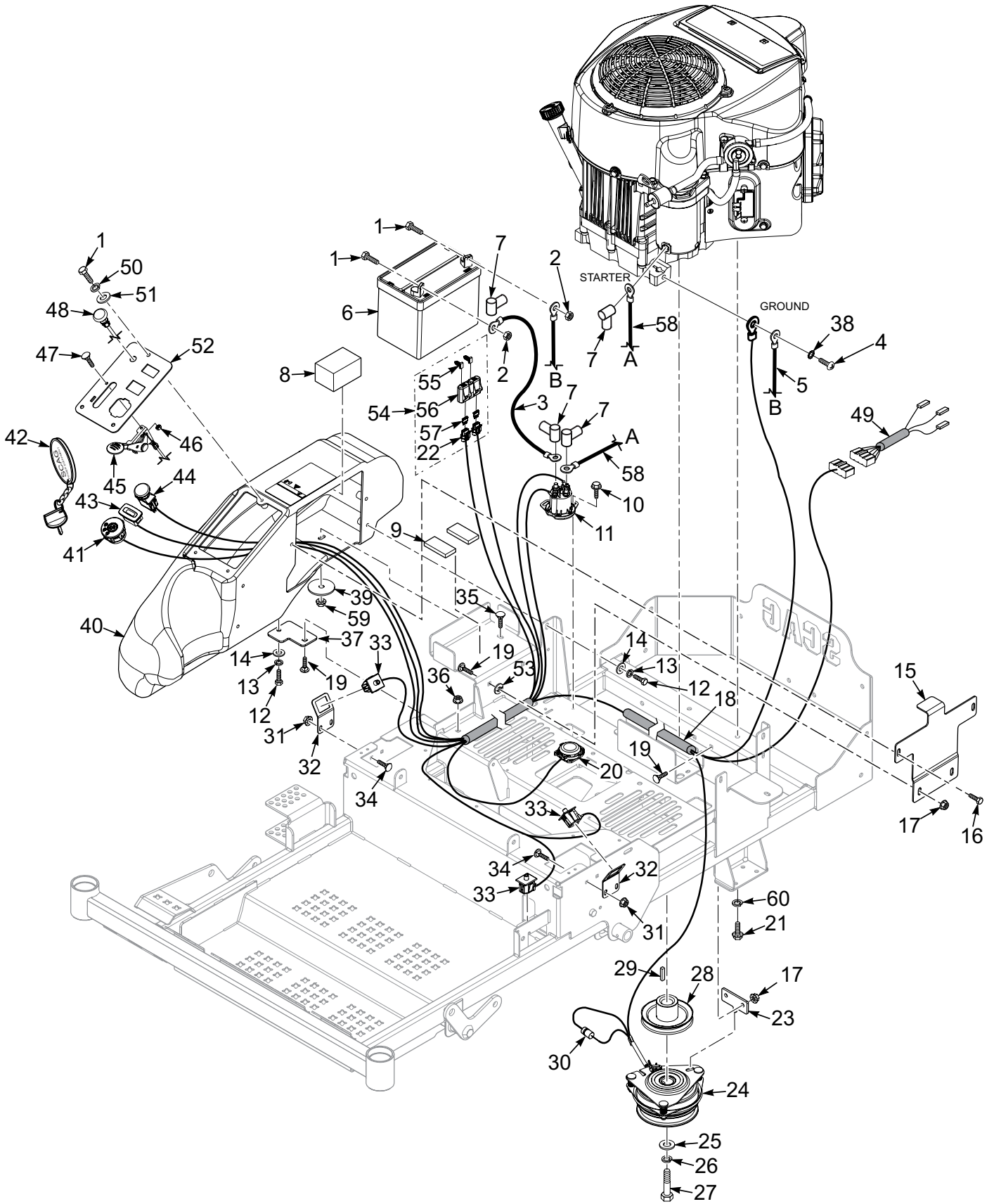



48, 52 & 61 ELECTRICAL SYSTEM

	Part No.	Qty	Description
1	04001-44	5	Bolt, Hex Head 1/4-20 x 1/2"
2	04020-02	2	Nut, 1/4-20 UNC
3	48029-29	1	Cable, Battery - 18" Red
4	04002-06	1	Screw, M8-1.25 X 16 Shakeproof
	04011-14	1	Screw, 1/4" - 20 x .75" (Kohler)
5	48029-14	1	Cable, Battery - 31-1/2" Black
6	*485212	1	Battery, 12v - 230CCA
7	48126	4	Rubber Boot
8	485506	1	Pad, Battery - Rubber
9	485505	2	Pad, Battery - Rubber
10	04011-14	2	Screw, 1/4-20 x 3/4" Shakeproof
11	483278	1	Solenoid, Sealed
12	04001-08	3	Bolt, Hex Head 5/16-18 x 3/4"
13	04030-03	3	Lockwasher, 5/16"
14	04040-15	3	Flatwasher, 5/16-.375 x .875 x .083
15	428184	1	Battery Hold Down
16	04017-15	2	Bolt, Hex Head 5/16-18 x 1/2" Serrated Flange
17	04117-01	4	Nut, 5/16-18 Elastic Stop
18	486518	1	Wire Harness
19	04003-12	5	Bolt, Carriage 5/16-18 x 3/4"
20	483474	1	Switch, Double Pole - Twist
21	04001-32	4	Bolt, Hex Head 3/8-16 x 1-1/4"
22	483629	2	Fuse Holder
23	427961	1	Plate, Anti-Rotation
	428752	1	Plate, Anti-Rotation - Warner (SZL-48H)
24	487077	1	Clutch, Warner (SZL-48H, SZL-52H)
	484063	1	Clutch, GT2 (SZL-61H)
25	04041-28	1	Flatwasher, 7/16-.496 x 1.75 x .25 (not used on SZL-48)
26	04030-05	1	Lockwasher, 7/16"
27	04102-12	1	Bolt, Hex Head 7/16-20 x 3/4" w/Patch
28	487032	1	Pulley, 4-1/2" Dia. - 1" Bore (SZL-48H, SZL-52H)
	487394	1	Pulley, 4-1/2" Dia. - 1" Bore (SZL-61H)
29	04063-01	1	Key, 1/4 x 1/4 x 1-1/4" (SZL-48H, SZL-52H)
	04063-42	1	Key, 1/4 x 1/4 x 3" (SZL-61H)
30	483958	1	Diode (part of wire harness)
31	04117-03	4	Nut, 1/4-20 Flange Elastic Stop
32	426727	2	Bracket, Switch
33	483473	3	Switch, Double Pole - Plunger
34	04003-02	4	Bolt, Carriage 1/4-20 x 3/4"

	Part No.	Qty	Description
35	04003-04	1	Bolt, Carriage 5/16-181 x 1"
36	04019-03	1	Nut, 5/16-18 Serrated Flange
37	428185	1	Mounting Bracket, Fuel Tank Front
38	04031-03	1	Lockwasher, 5/16" Ext.
39	04041-38	1	Flatwasher, 3/8-.406 x 2.25 x .188
40	463191	1	Console Tank, SZL
41	483472	1	Ignition Switch
42	462069	1	Key Fob Assembly
	483609	1	Key w/Shroud Only
43	484565	1	Hourmeter, Inductive
44	485833	1	Switch, PTO Sealed
45	483434	1	Throttle Cable - Kohler
	483645	1	Throttle Cable - Kawasaki, Briggs, Scag
46	04021-26	2	Nut, #10-24 Elastic Stop
47	04003-43	2	Bolt, Carriage #10-24 x 1/2"
48	483435	1	Choke Control - Kohler
	483646	1	Choke Control - Kawasaki, Briggs, Scag
49	483529	1	Wire Harness Adapter, Kawasaki Only
50	04030-02	3	Lockwasher, 1/4"
51	04040-14	3	Flatwasher, 1/4-.312 x .750 x .065
52	462793	1	Instrument Panel w/Decal
53	04024-03	2	Nut, 5/16 Push-On
54	483642	1	Double Fuse Assembly (incl. 22, 55, 56, 57)
55	482588	2	Clip, Wire
56	483571	1	Cover, Double
57	48298	2	Fuse, 20 Amp
58	48029-29	1	Cable, Battery - 18" Red (Kawasaki)
	48029-13	1	Cable, Battery - 25" Red (Kohler)
59	04021-10	1	Nut, 5/16-18 Elastic Stop
60	04030-04	4	Washer, Lock 3/8 Spring
	04031-03	1	Washer, Lock 5/16 Ext Tooth (ground)

\* Not available through Scag Power Equipment. Purchase locally.

## FUEL SYSTEM

\*For California Only

SZL-36 & 42 Models Only    SZL-48 52 & 61 Models Only

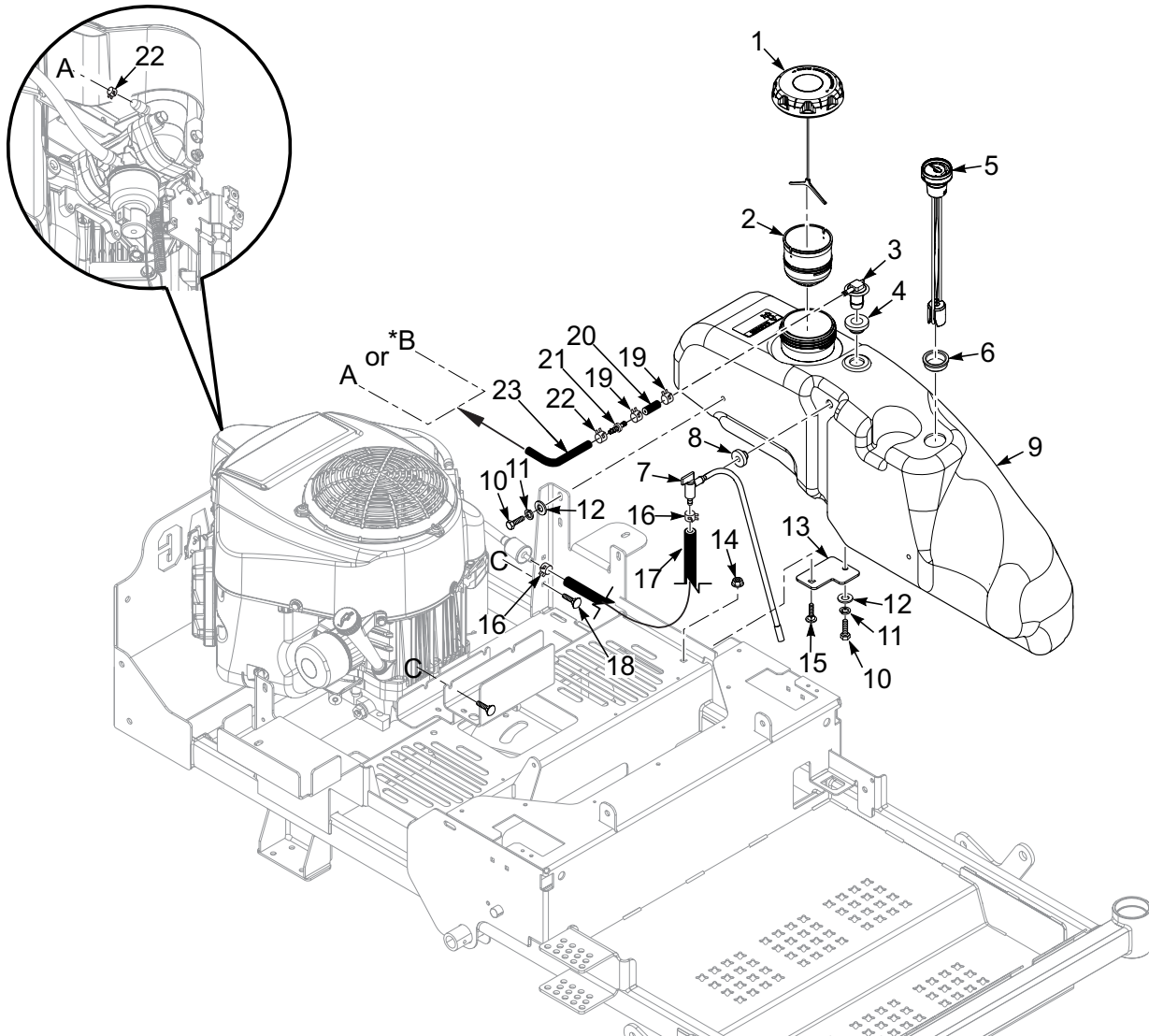
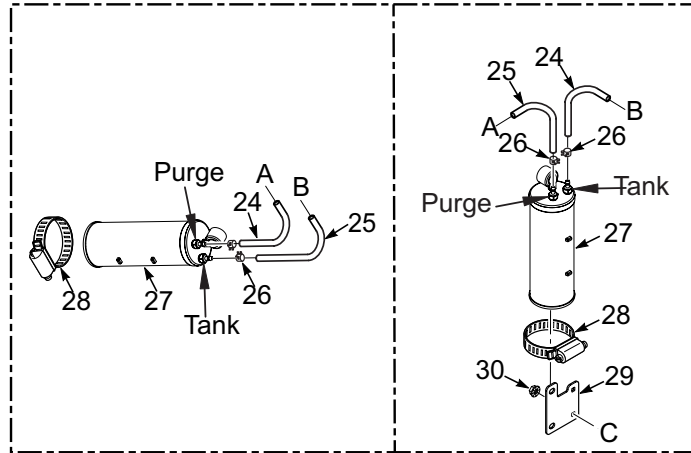

FUEL SYSTEM

Ref. No.	Part No.	Qty	Description
1	484286	1	Fuel Cap
	*484297	1	Fuel Cap, C.A.R.B.
2	484279-03	1	Fuel Neck Insert
3	484333	1	Remote Vent, No Valve
4	484285	1	Grommet, Kelch
5	485393	1	Fuel Gauge (requires #6)
6	485394	1	Grommet, Fuel Gauge
7	485391	1	Valve, Fuel Shut Off
8	482571	1	Bushing, .56 Dia. Viton
9	463188	1	Fuel Tank Assembly (incl. 1, 2, 3, 4, 5, 6, 7, 8) SZL-36, 42
	463190	1	Fuel Tank Assembly (incl. 3, 4, 5, 6, 7, 8) SZL-48, 52 & 61
10	04001-08	4	Bolt, Hex Head 5/16-18 x 3/4"
11	04030-03	4	Lockwasher, 5/16"
12	04040-15	4	Flatwasher, 5/16-.375 x .875 x .083
13	**428185	1	Mounting Bracket, Fuel Tanks Front
14	**04019-03	1	Nut, 5/16-18 Serrated Flange
15	**04003-12	1	Bolt, Carriage 5/16-18 x 3/4"
16	48059-01	2	Clamp, Fuel Hose 1/4"
17	483617	-	Hose, Non-perm Fuel - 1/4" Dia. (order by inch)
18	04003-02	2	Bolt, Carriage 1/4-20 x 3/4"
19	48059-02	2	Clamp, Fuel Hose 7/32" ID
20	484347	2	Hose, 1/4" Vapor Return (order by inch)
21	484343-01	1	Mender, 1/4 x 3/16 w/.02 Hole
22	48059-05	2	Clamp, Vapor Hose -3/16"
23	484345	-	Hose, Vapor (order by inch)
*24	484345	-	Hose, Vapor (order by inch)
*25	484345	-	Hose, Vapor (order by inch)
*26	48059-05	2	Clamp, Vapor Hose - 3/16"
*27	484287	1	Carbon Canister, 400cc
	484366	1	Dust Filter (not shown. Incl. with #27)
*28	48136-17	17	Clamp, 3-1/2" Max. Dia.
*29	**426326	1	Bracket, Canister Mount
*30	04019-02	1	Nut, 1/4-20 Serrated Flange

\* California Only

\*\* Excludes SZL-36

### HYDRO-GEAR TRANSAXLE (ZT-2800 36"/42")

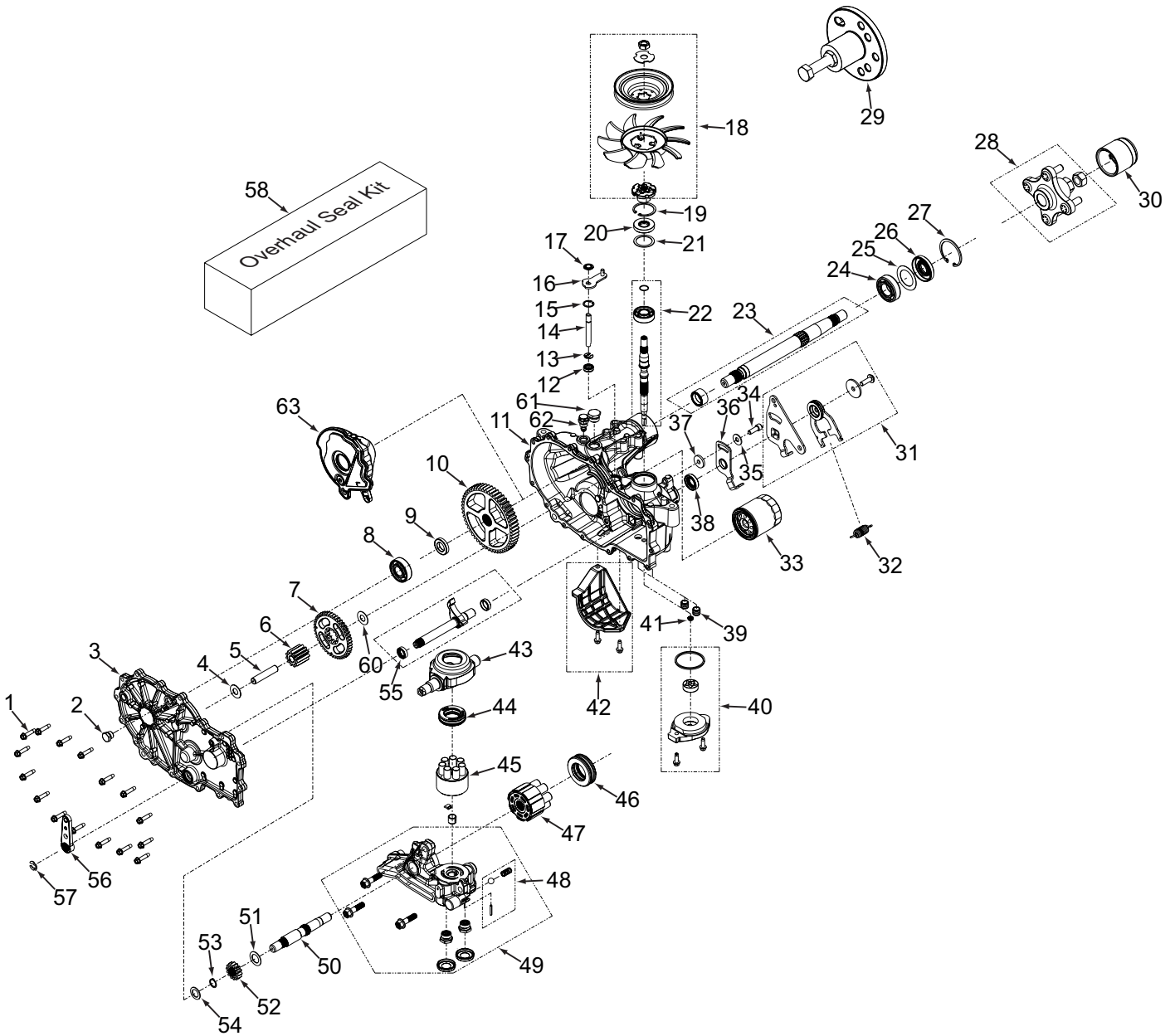

# ILLUSTRATED PARTS LIST

## HYDRO-GEAR TRANSAXLE (ZT-2800 36"/42")

Ref. No.	Part No.	Description
1	HG53246	Screw, Hex Washer
2	HG54730	Plug, External Hex Vent 9/16-18
3	HG73096	Kit, Side Cover LH
	HG73095	Kit, Side Cover RH
4	HG50132	Washer, Flat, .51 x 1 x .03
5	HG51083	Pin, Jackshaft
6	HG52583	Gear, 11T
7	HG52110	Gear, 45T
8	HG72749	Kit, Bearing
9	HG53336	Spacer, .75 x 1.32 x .257
10	HG52108	Gear, 54T
11	HG73073	Kit, Main Housing LH, Charge, Control
	HG73069	Kit, Main Housing RH, Charge, Control
12	HG55232	Seal, Lip, .375 x .75 x .25
13	HG51628	Ring, Retaining External .375
14	HG52136	Rod, Bypass .375 x 2.88
15	HG51627	Ring, Retaining .75, Internal
16	HG52370	Arm, Bypass (LH)
	HG51910	Arm, Bypass (RH)
17	HG51630	Ring, Retaining .375, External
18	HG72979	Kit, Fan/Pulley
19	HG50329	Ring, Retaining Internal
20	HG51161	Seal, Lip, 17 x 40 x 7
21	HG50951	Washer, Flat, 1.23 x 1.57 x .04
22	HG73047	Kit, Input Shaft
23	HG71569	Kit, Shaft Axle
24	HG53656	Bearing, 25.4 x 52 x 15 Ball (6205R)
25	HG53514	Washer, Flat, 1.355 x 2.035 x .021
26	HG53699	Seal, Lip, TC4, 1 x 2.06 x .38
27	HG50859	Ring, Retaining 2.25 Internal
28	HG71446	Kit, Hub 4 Bolt
29	HG72320	Kit, Hub Puller
30	HG53501	Cap, Axle
31	HG71598	Kit, RTN Bidirectional (LH)
	HG71595	Kit, RTN Bidirectional (RH)
32	HG51605	Spring, Extension
33	HG52114	Filter, Spin-on 2.6 x 3
34	HG51616	Bolt, 5/16-24 x 7/8 (w/patch)
35	HG44130	Washer, Flat .34 x .88 x .06
36	HG51946	Arm, Return Left (LH)
	HG51945	Arm, Neutral Right (RH)
37	HG54315	Spacer, .32 ID x 1.005 OD x .1495 THK
38	HG51140	Seal, Lip 18 x 32 x 7
39	HG54501	Tube, Charge Triple O-Ring
40	HG72274	Kit, Charge
41	HG72291	Kit, Gerotor Seal

Ref. No.	Part No.	Description
42	HG71854	Kit, Filter Guard (LH)
	HG73041	Kit, Filter Guard (RH)
43	HG51048	Swashplate, Trunnion
44	HG50551	Bearing, Thrust 30 x 52 x 13
45	HG70723	Kit, Block 7 Piston
46	HG51462	Bearing, Thrust 35 x 62 x 18
47	HG72882	Kit, 16cc Cylinder Block Assembly
48	HG71436	Kit, Charge Relief
49	HG72515	Kit, Center Section, LH Charge
	HG72516	Kit, Center Section, RH Charge
50	HG52150	Shaft, Motor
51	HG51069	Washer, Flat, .71 x 1.16 x .04
52	HG52109	Gear, 14T
53	HG44145	Ring, Retaining, Motor Shaft
54	HG44371	Washer, Flat, .63 x 1 x .05
55	HG73121	Kit, Inboard, RH Rot B / LH Rot A (LH)
	HG73120	Kit, Inboard, RH Rot A / LH Rot B (RH)
56	HG53973	Handle, Actuating
57	HG53019	Ring, Retaining - External .438
58	HG73107	Kit, Seal (ZT-2800) (INCL. 12,13,14,15,17,19, 20,38,39,41,53,57)
59	*HG50928	Tube, Sealant
60	HG50132	Washer, .51 x 1.00 .03 Flat
61	HG54974	Plug 3/4 - 16
62	HG55380	Fitting 9/16 - 18, Breather
63	HG55072	Expansion Tank LH, Internal
	HG55071	Expansion Tank RH, Internal

\* Item not shown

## TUFF TORQ TRANSAXLE - LH (TZ-450C-X 48", 52", 61")

TZ 450C-X  
 Ser. No. ALM00000001 - 99999999  
 Rev. 07-17-21

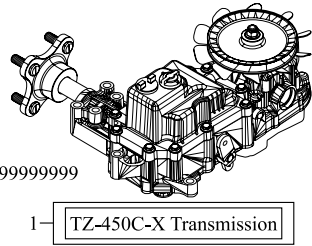

1 - TZ-450C-X Transmission

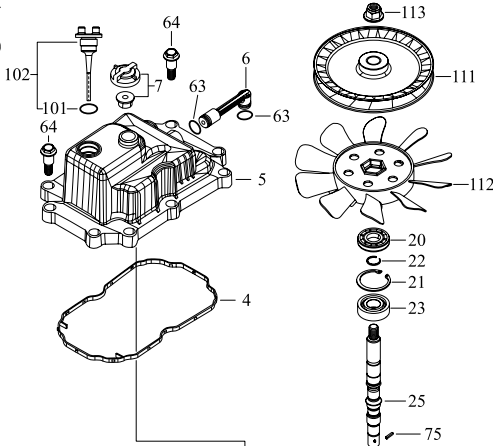
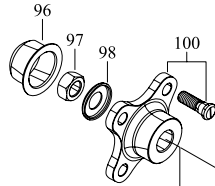

TT-3 - TUFF TECH OIL

200 - TZ450C-X Seal Kit

Kit Includes	
#4	#43
#6	#46
#7	(4) #63
(2) #8	#99
#11	#104
(2) #14	#105
#20	#113
(4) #27	TT-3

All parts may not be used.

201 - TZ450C-X Repair Kit

Kit Includes	
#40	#50
#200 - Seal Kit	#52

All parts may not be used.

202 - TZ450C-X Oil Change Kit

Kit Includes	
#7	#105
#10	TT-3
#104	

All parts may not be used.

**Tightening Specs.**

Bolt Size	Torque
M8	16~18 ft.lb. (21~24 N.m)
M10	33~47 ft.lb. (45~64 N.m)
Drain Bolt	15~18 ft.lb. (20~25 N.m)
Lock Nut Size	
3/4"	173~210 ft.lb. (235~285 N.m)
M10	53~62 ft.lb. (39~46 N.m)

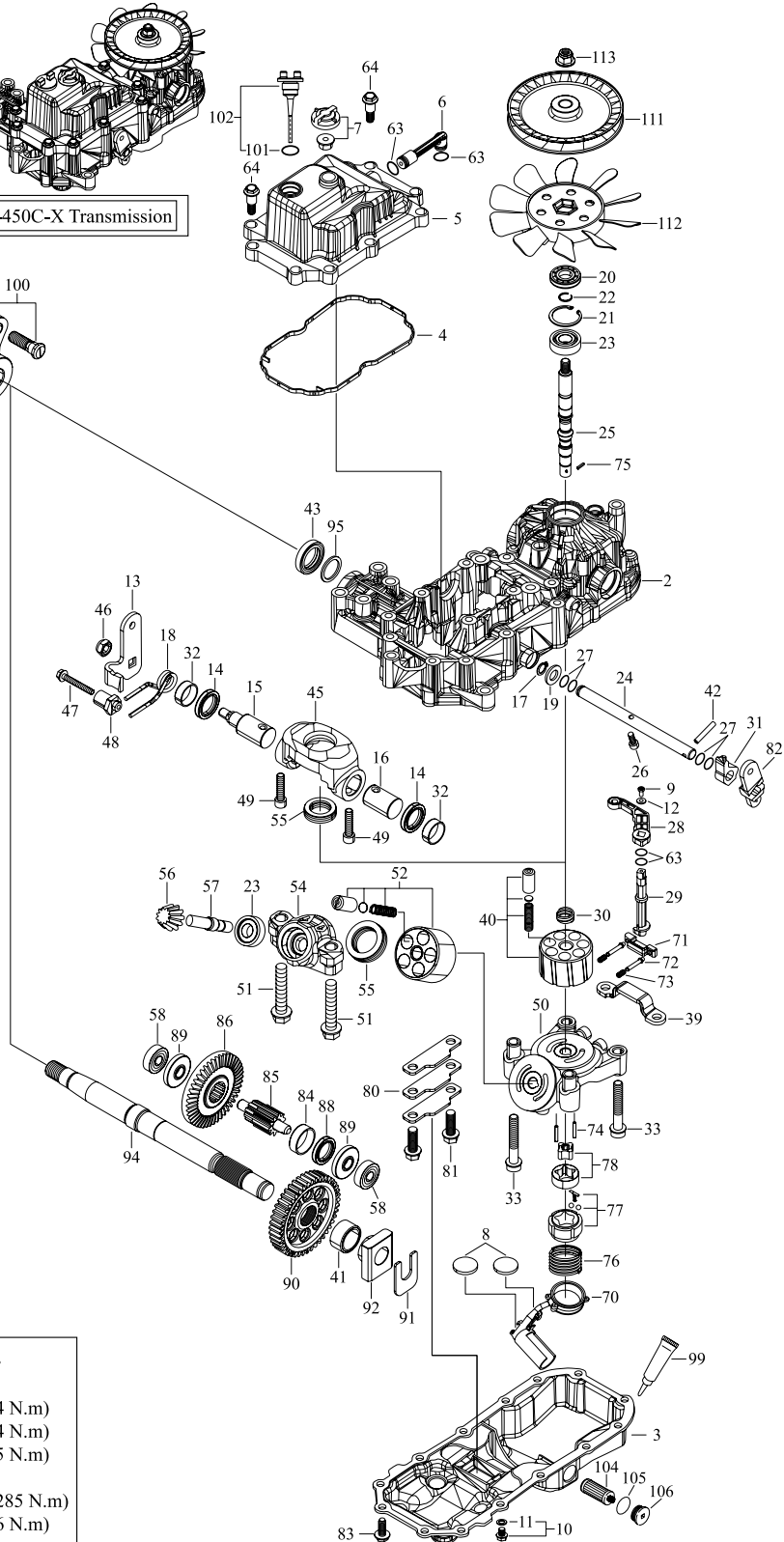

# ILLUSTRATED PARTS LIST

## TUFF TORQ TRANSAXLE - LH (TZ-450C-X 48", 52", 61 ")

Ref. No.	Part No.	Description	Ref. No.	Part No.	Description
TT-3	TT187Q0899000	Tuff Tech Oil (3 Liter Bottle)	63	TT24311240100	O-Ring 1a P10a
*1	486650	Tz-450c-X Transaxle (Pre-Filled)	64	TT26476080302	Tapping Bolt 8*30
2	TT187Q1624150	Upper Housing X	70	TT187Q2124800	Bracket Assy Fts
3	TT187Q2124360	Lower Housing Fy	71	TT187Q1629350	Bypass Guide
4	TT187Q1624450	Square Seal	72	TT187Q1629370	Bypass Pin
5	TT187Q2124550	Top Cover A	73	TT187Q1629390	Bypass Spring
6	TT187Q1624440	Bypass Piping	74	TT22351030018	Pin 3.0 * 18
7	TT168T2024250	Vent Valve	75	TT1A646088410	Pin 2.5* 9.8
8	TT19216324360	Magnet 28 * 3.5	76	TT1A646088450	Charge Spring
9	TT22857400080	Screw 4.0*8	77	TT187Q0826100	Pump Case
10	TT1A632099320	Drain Bolt Kit	78	TT1A646031100	Rotor Set
11	TT22190-100000	Washer Seal 10	80	TT187Q1624300	Final Plate
12	TT187Q1629410	Washer 4.5*10*1	81	TT26106100302	Bolt 10 * 30
13	TT187Q1629710	Control Lever L	82	TT187Q2136150	Brake Arm
14	TT187Q1629100	Seal, Tc253506	83	TT26476080202	Tapping Screw 8 * 20
15	TT187Q1629800	Control Shaft	84	TT187Q1633380	Final Pinion Collar
16	TT187Q1629810	Control Shaft Short	85	TT187Q2133400	Final Pinion Shaft
17	TT19215489090	Snap Ring	86	TT187Q1633150	Reduction Gear S
18	TT187Q1629860	Torsion Spring	88	TT187Q2133420	Reduction Collar
19	TT22137120000	Washer 12	89	TT187Q2133420	Washer 14.1 X 30 X 3.5
20	TT187T0134390	Oil Seal 15*35*07	90	TT187Q1633710	Final Gear Sv
21	TT22252000350	Snap Ring C 35	91	TT187Q1634060	Clip
22	TT17808002080	Ring 1.2	92	TT19215434240	Axle Bush
23	TT1A646034770	Bearing	94	TT187Q1634150	Axle Shaft T
24	TT187Q1636200	Brake Shaft	95	TT187Q0834370	Washer
25	TT187Q2125100	Pump Shaft C	*96	TT187Q0634410	Nut Cap
26	TT26450060162	Socket Bolt 6*16	*97	TT187Q0634120	Lock Nut 3/4-16
27	TT24311000120	O-Ring 1a P12	*98	TT187Q2134300	Flange Spacer
*28	TT187Q1629510	Bypass Lever	99	TT1A646099500	Sealant
29	TT187Q1629310	Bypass Shaft	*100	TT187Q2134800	Flange Assy.
30	TT19215425200	Pump Spring	101	TT24311000160	O-Ring 1a P16
31	TT187Q1636370	Brake Fork 20 Cr	*102	TT187P0113190	Dipstick Assy.
32	TT187Q1629450	Control Bush Lfb2510	*104	TT1A632026450	Filter
33	TT1A632010650	M10 * 65 Bolt	*105	TT24351240400	O-Ring 1a 24040
39	TT187Q2124740	Check Stopper Pfg	*106	TT1A637024380	Cap 40
40	TT187Q1625150	Cylinder Block Kit / Order Repair Kit	*111	TT187Q2125700	Pulley,5.5
41	TT19215434240	Bushing 25.4	*112	TT187Q1683060	Fan
42	TT22351050032	Spring Pin 5 * 32	*113	TT19216829860	Lock Nut 10
43	TT187Q1634050	Seal Tc284008	*200	TT187Q2199050	Seal Kit Tz-450
45	TT187Q1684530	Swashplate	*201	TT187Q2199140	Repair Kit Tz-450 C
46	TT187Q0610070	Lock Nut 10	*202	TT187Q2199300	Tz 450 Oil Change Kit
47	TT26106060452	Bolt 6*45			
48	TT187T0029940	Fulcrum			
49	TT26450080352	Bolt 8 * 35			
50	TT187Q2124450	Centercase Cp / Order Repair Kit			
51	TT26106120652	Bolt 12*65			
52	TT168T2025080	Cylinder Block Kit(Motor / Order Repair Kit			
54	TT187Q1624500	Motor Housing			
55	TT187T0034750	Thrust Bearing			
56	TT187Q1625430	Motor Gear S			
57	TT187Q1625300	Motor Shaft			
58	TT187Q1633520	Bearing 6201 Cn			

\* Available through Scag Power Equipment

### TUFF TORQ TRANSAXLE - RH (TZ-450C-Y 48", 52", 61 ")

TZ 450C-Y  
 Ser. No. AMM00000001 - 99999999  
 Rev. 07-17-21

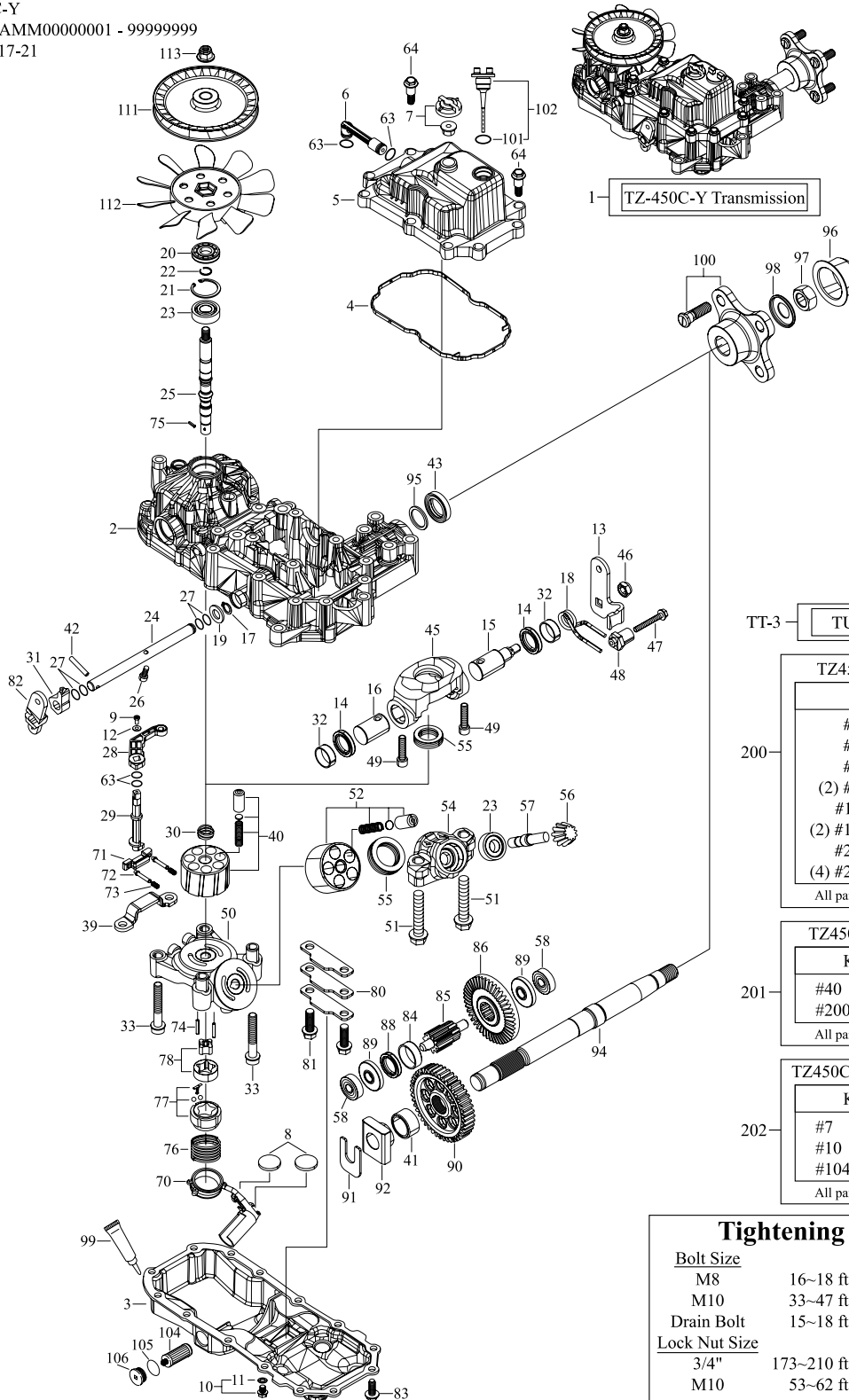

TT-3 TUFF TECH OIL

200

TZ450C-Y Seal Kit	
Kit Includes	
#4	#43
#6	#46
#7	(4) #63
(2) #8	#99
#11	#104
(2) #14	#105
#20	#113
(4) #27	TT-3

All parts may not be used.

201

TZ450C-Y Repair Kit	
Kit Includes	
#40	#50
#200 - Seal Kit	#52

All parts may not be used.

202

TZ450C-Y Oil Change Kit	
Kit Includes	
#7	#105
#10	TT-3
#104	

All parts may not be used.

**Tightening Specs.**

Bolt Size	Torque
M8	16~18 ft.lb. (21~24 N.m)
M10	33~47 ft.lb. (45~64 N.m)
Drain Bolt	15~18 ft.lb. (20~25 N.m)
Lock Nut Size	
3/4"	173~210 ft.lb. (235~285 N.m)
M10	53~62 ft.lb. (39~46 N.m)



# ILLUSTRATED PARTS LIST

## TUFF TORQ TRANSAXLE - RH (TZ-450C-Y 48", 52", 61 ")

Ref. No.	Part No.	Description
TT-3	TT187Q0899000	Tuff Tech Oil (3 Liter Bottle)
*1	486651	Tz-450c-Y Transaxle (Pre-Filled)
2	TT187Q1624160	Upper Housing X
3	TT187Q2124351	Lower Housing Fy
4	TT187Q1624450	Square Seal
5	TT187Q2124550	Top Cover A
6	TT187Q1624440	Bypass Piping
7	TT168T2024250	Vent Valve
8	TT19216324360	Magnet 28 * 3.5
9	TT22857400080	Screw 4.0*8
10	TT1A632099320	Drain Bolt Kit
11	TT22190-100000	Washer Seal 10
12	TT187Q1629410	Washer 4.5*10*1
13	TT187Q1629720	Control Lever L
14	TT187Q1629100	Seal, Tc253506
15	TT187Q1629800	Control Shaft
16	TT187Q1629810	Control Shaft Short
17	TT19215489090	Snap Ring
18	TT187Q1629860	Torsion Spring
19	TT22137120000	Washer 12
20	TT187T0134390	Oil Seal 15*35*07
21	TT22252000350	Snap Ring C 35
22	TT17808002080	Ring 1.2
23	TT1A646034770	Bearing
24	TT187Q1636200	Brake Shaft
25	TT187Q2125100	Pump Shaft C
26	TT26450060162	Socket Bolt 6*16
27	TT24311000120	O-Ring 1a P12
*28	TT187Q1629510	Bypass Lever
29	TT187Q1629310	Bypass Shaft
30	TT19215425200	Pump Spring
31	TT187Q1636370	Brake Fork 20 Cr
32	TT187Q1629450	Control Bush Lfb2510
33	TT1A632010650	M10 * 65 Bolt
39	TT187Q2124740	Check Stopper Pfg
40	TT187Q1625150	Cylinder Block Kit / Order Repair Kit
41	TT19215434240	Bushing 25.4
42	TT22351050032	Spring Pin 5 * 32
43	TT187Q1634050	Seal Tc284008
45	TT187Q1684530	Swashplate
46	TT187Q0610070	Lock Nut 10
47	TT26106060452	Bolt 6*45
48	TT187T0029940	Fulcrum
49	TT26450080352	Bolt 8 * 35
50	TT187Q2124450	Centercase Cp / Order Repair Kit
51	TT26106120652	Bolt 12*65
52	TT168T2025080	Cylinder Block Kit(Motor / Order Repair Kit
54	TT187Q1624500	Motor Housing
55	TT187T0034750	Thrust Bearing
56	TT187Q1625430	Motor Gear S
57	TT187Q1625300	Motor Shaft
58	TT187Q1633520	Bearing 6201 Cn

Ref. No.	Part No.	Description
63	TT24311240100	O-Ring 1a P10a
64	TT26476080302	Tapping Bolt 8*30
70	TT187Q2124800	Bracket Assy Fts
71	TT187Q1629350	Bypass Guide
72	TT187Q1629370	Bypass Pin
73	TT187Q1629390	Bypass Spring
74	TT22351030018	Pin 3.0 * 18
75	TT1A646088410	Pin 2.5* 9.8
76	TT1A646088450	Charge Spring
77	TT187Q0826100	Pump Case
78	TT1A646031100	Rotor Set
80	TT187Q1624300	Final Plate
81	TT26106100302	Bolt 10 * 30
82	TT187Q2136150	Brake Arm
83	TT26476080202	Tapping Screw 8 * 20
84	TT187Q1633380	Final Pinion Collar
85	TT187Q2133400	Final Pinion Shaft
86	TT187Q1633150	Reduction Gear S
88	TT187Q2133420	Reduction Collar
89	TT187Q2133420	Washer 14.1 X 30 X 3.5
90	TT187Q1633710	Final Gear Sv
91	TT187Q1634060	Clip
92	TT19215434240	Axle Bush
94	TT187Q1634150	Axle Shaft T
95	TT187Q0834370	Washer
*96	TT187Q0634410	Nut Cap
*97	TT187Q0634120	Lock Nut 3/4-16
*98	TT187Q2134300	Flange Spacer
99	TT1A646099500	Sealant
*100	TT187Q2134800	Flange Assy.
101	TT24311000160	O-Ring 1a P16
*102	TT187P0113190	Dipstick Assy.
*104	TT1A632026450	Filter
*105	TT24351240400	O-Ring 1a 24040
*106	TT1A637024380	Cap 40
*111	TT187Q2125700	Pulley,5.5
*112	TT187Q1683060	Fan
*113	TT19216829860	Lock Nut 10
*200	TT187Q2199050	Seal Kit Tz-450
*201	TT187Q2199140	Repair Kit Tz-450 C
*202	TT187Q2199300	Tz 450 Oil Change Kit

\* Available through Scag Power Equipment

## REPLACEMENT DECALS AND INFORMATION PLATES

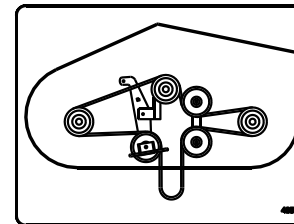
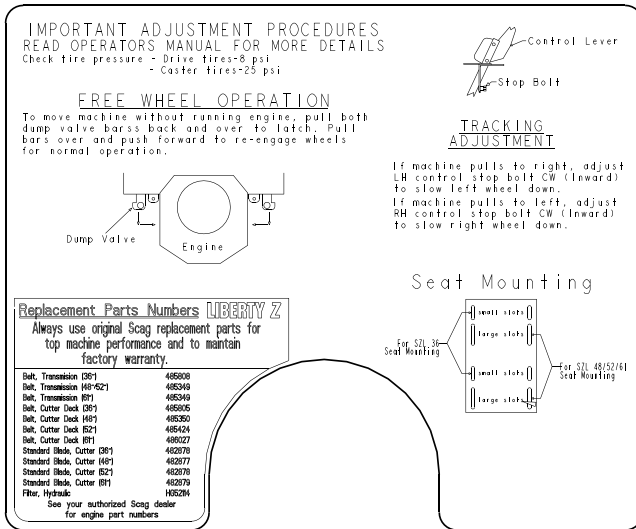
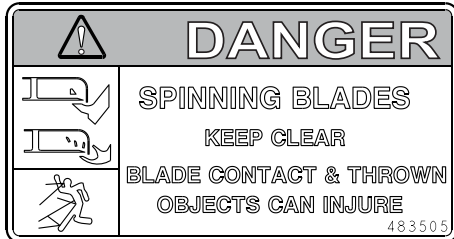
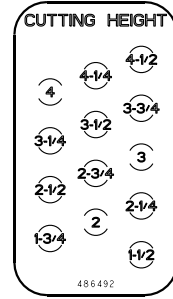

# 52 HERO

# LIBERTY Z

USA SCAG

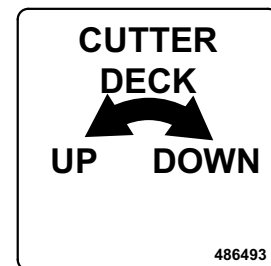

**REPLACEMENT DECALS AND INFORMATION PLATES**

Ref. No.	Part No.	Qty	Description
1	483402	2	Decal, Belt Cover
2	483405	1	Decal, Warning
3	485551	1	Decal, Start/Drive
4	483505	2	Decal, Spinning Blades
5	482100	2	Decal, Traction Control
6	486492	1	Decal, Height of Cut
7	486797	1	Decal, 36 Hero
	486896	1	Decal, 42 Hero
	486798	1	Decal, 48 Hero
	486799	1	Decal, 52 Hero
	486800	1	Decal, 61Hero
8	483406	1	Decal, Knives
9	486992	1	Decal, Adjustments - SZL
10	485820	1	Decal, Instrument Panel - SZL (36)
	485387	1	Decal, Instrument Panel - SZL (48 52 & 61)
11	486517	2	Decal, Liberty Z - Fuel Tank
12	485821	1	Decal, Belt Routing - SZL (36)
	485516	1	Decal, Belt Routing - SZL(48 52& 61)
13	486493	1	Decal, Cutter Deck Lift Control
*	483900	1	Decal, Warning Spark Arrestor (California Only) - Not Shown
14	485403	1	Decal, USA

## ELECTRICAL SCHEMATIC

