

SCAG

POWER EQUIPMENT

OPERATOR'S MANUAL

CHEETAH II



Models: **SCZII-61V-36BV**
SCZII-61V-37BV-EFI
SCZII-61V-38CV-EFI
SCZII-61V-38FX-EFI
SCZII-61V-40BV-EFI
SCZII-61RD-38CV-EFI
SCZII-61RD-38FX-EFI
SCZII-72V-37BV-EFI
SCZII-72V-38CV-EFI
SCZII-72V-38FX-EFI
SCZII-72V-40BV-EFI
SCZII-72RD-40BV-EFI

Congratulations on owning a Scag mower! This manual contains the operating instructions and safety information for your Scag mower. Reading this manual can provide you with assistance in maintenance and adjustment procedures to keep your mower performing to maximum efficiency. The specific models that this book covers are listed on the inside cover. Before operating your machine, please read all the information enclosed.



WARNING

FAILURE TO FOLLOW SAFE OPERATING PRACTICES MAY RESULT IN SERIOUS INJURY OR DEATH.

- Read this manual completely as well as other manuals that came with your mower.
- DO NOT operate on steep slopes. To check a slope, attempt to back up it (with the cutter deck down). If the machine can back up the slope without the wheels slipping, reduce speed and use extreme caution.
- Under no circumstances should the machine be operated on slopes greater than 15 degrees. ALWAYS FOLLOW OSHA APPROVED OPERATION.
- Stay two cut widths away from slopes, drop offs, ditches, water, retaining walls, avoid any slope exceeding 15 degrees, and do not mow under trees on slopes with the roll bar down.
- DO NOT mow on wet grass. Wet grass reduces traction and steering control.
- Keep all shields in place, especially the grass discharge chute.
- Before performing any maintenance or service, stop the machine and remove the spark plug wire and ignition key.
- If a mechanism becomes clogged, stop the engine before cleaning.
- Keep hands, feet and clothing away from power-driven parts.
- Keep others off the mower (only one person at a time)

REMEMBER - YOUR MOWER IS ONLY AS SAFE AS THE OPERATOR!

HAZARD CONTROL AND ACCIDENT PREVENTION ARE DEPENDENT UPON THE AWARENESS, CONCERN, PRUDENCE, AND PROPER TRAINING OF THE PERSONNEL INVOLVED IN THE OPERATION, TRANSPORT, MAINTENANCE, AND STORAGE OF THE EQUIPMENT.

This manual covers the operating instructions and illustrated parts list for:

SCZII-61V-36BV	with a serial number of	Z1300001 to Z1399999
SCZII-61V-37BV-EFI	with a serial number of	Z1400001 to Z1499999
SCZII-61V-38CV-EFI	with a serial number of	Z1500001 to Z1599999
SCZII-61V-38FX-EFI	with a serial number of	Z1600001 to Z1699999
SCZII-61V-40BV-EFI	with a serial number of	Z1700001 to Z1799999
SCZII-61RD-38CV-EFI	with a serial number of	Z1800001 to Z1899999
SCZII-61RD-38FX-EFI	with a serial number of	Z1900001 to Z1999999
SCZII-72V-37BV-EFI	with a serial number of	Z2000001 to Z2099999
SCZII-72V-38CV-EFI	with a serial number of	Z2100001 to Z2199999
SCZII-72V-38FX-EFI	with a serial number of	Z2200001 to Z2299999
SCZII-72V-40BV-EFI	with a serial number of	Z2300001 to Z2399999
SCZII-72RD-40BV-EFI	with a serial number of	Z2400001 to Z2499999

Always use the entire serial number listed on the serial number tag when referring to this product.

Table of Contents

SECTION 1 - GENERAL INFORMATION.....	1
1.1 INTRODUCTION	1
1.2 DIRECTION REFERENCE.....	1
1.3 SERVICING THE ENGINE AND DRIVE TRAIN COMPONENTS	1
1.4 SYMBOLS.....	1
SECTION 2 - SAFETY INFORMATION	3
2.1 INTRODUCTION	3
2.2 SIGNAL WORDS.....	3
2.3 BEFORE OPERATION CONSIDERATIONS.....	4
2.4 TESTING THE SAFETY INTERLOCK SYSTEM	5
2.5 OPERATION CONSIDERATIONS	5
2.6 ROLL-OVER PROTECTIVE STRUCTURE.....	7
2.7 MAINTENANCE CONSIDERATIONS AND STORAGE	9
2.8 USING A SPARK ARRESTOR.....	9
2.9 SPARK IGNITION SYSTEM.....	9
2.10 SAFETY AND INSTRUCTIONAL DECALS	10
SECTION 3 - SPECIFICATIONS	12
3.1 ENGINE	12
3.2 ELECTRICAL.....	12
3.3 POWER HEAD	13
3.4 CUTTER DECK	13
3.5 HYDRAULIC SYSTEM.....	13
3.6 WEIGHTS AND DIMENSIONS.....	14
3.7 PRODUCTIVITY.....	14
SECTION 4 - OPERATING INSTRUCTIONS	16
4.1 TIGER EYE INSTRUMENT IDENTIFICATION	16
4.2 CONTROLS IDENTIFICATION	18
4.3 SAFETY INTERLOCK SYSTEM.....	19
4.4 TESTING THE SAFETY INTERLOCK SYSTEM	19
4.5 INITIAL RUN-IN PROCEDURES	20
4.6 STARTING THE ENGINE	20
4.7 GROUND TRAVEL AND STEERING.....	20
4.8 ENGAGING THE DECK DRIVE (CUTTER BLADES)	22
4.9 HILLSIDE OPERATION	22
4.10 PARKING THE MOWER.....	22
4.11 AFTER OPERATION	23
4.12 REMOVING CLOGGED MATERIAL.....	23
4.13 MOVING MOWER WITH ENGINE STOPPED.....	23
4.14 RECOMMENDATIONS FOR MOWING.....	23

4.15 ADJUSTING CUTTING HEIGHT.....	24
4.16 ADJUSTING THE HEIGHT ADJUST PEDAL	24
4.17 ADJUSTING THE STEERING LEVERS.....	25
4.18 SETTING THE SPEED CONTROL.....	25
4.19 ADJUSTING THE OPERATOR SUSPENSION PLATFORM	26
4.20 TOWING.....	26
SECTION 5 - TROUBLESHOOTING CUTTING CONDITIONS	27
SECTION 6 - ADJUSTMENTS	30
6.1 PARKING BRAKE ADJUSTMENT	30
6.2 TRAVEL ADJUSTMENTS.....	30
6.3 LOW / HIGH SPEED ADJUSTMENT	31
6.4 THROTTLE CONTROL AND CHOKE ADJUSTMENTS.....	32
6.5 BELT ADJUSTMENT.....	32
6.6 BELT ALIGNMENT	32
6.7 CUTTER DECK ADJUSTMENTS	32
6.8 CUSTOM-CUT BAFFLE ADJUSTMENT (EXCLUDES REAR DISCHARGE)	34
6.9 ADJUSTING THE STEERING DAMPENERS.....	35
6.10 ELECTRIC CLUTCH ADJUSTMENT.....	35
SECTION 7 - MAINTENANCE.....	36
7.1 MAINTENANCE CHART - RECOMMENDED SERVICE INTERVALS.....	36
7.2 LUBRICATION.....	37
7.3 HYDRAULIC SYSTEM.....	39
7.4 ENGINE OIL	40
7.5 ENGINE FUEL SYSTEM	41
7.6 ENGINE AIR CLEANER	42
7.7 BATTERY	42
7.8 DRIVE BELTS.....	43
7.9 CUTTER BLADES.....	43
7.10 TIRES.....	45
7.11 BODY, DECK, AND UPHOLSTERY	45
SECTION 8 - ILLUSTRATED PARTS LIST.....	46
8.1 SCAG APPROVED ATTACHMENTS AND ACCESSORIES	46
61V & 72V CUTTER DECKS	48
61RD & 72 RD CUTTER DECK.....	50
CUTTER DECK CONTROLS	52
SHEET METAL COMPONENTS	54
SCZII ROLL-OVER PROTECTION STRUCTURE	56
SCZII SEAT ASSEMBLY.....	58
SCZII SUSPENSION SEAT ASSEMBLY.....	60
SCZII SUSPENSION SYSTEM.....	62
SCZII STEERING COMPONENTS.....	64

Table of Contents

SCZII DRIVE SYSTEM COMPONENTS	66
SCZII SPEED CONTROL COMPONENTS	68
SCZII BRAKE COMPONENTS	70
SCZII HYDRAULIC SYSTEM.....	72
SCZII FUEL SYSTEM	74
SCZII ENGINE & ATTACHING PARTS.....	76
ZT-5400 TRANSAXLE ASSEMBLY	78
SCZII ELECTRICAL SYSTEM	80
SCZII EFI ELECTRICAL SYSTEM	82
REPLACEMENT DECALS AND INFORMATION PLATES	84
SCZII ELECTRICAL SCHEMATIC.....	86
SCZII BV-EFI / CV-EFI ELECTRICAL SCHEMATIC.....	87
BRIGGS & STRATTON / KOHLER- EFI ADAPTER HARNESS ELECTRICAL SCHEMATIC.....	88
SCZII FX-EFI ELECTRICAL SCHEMATIC.....	89
LIMITED WARRANTY - COMMERCIAL EQUIPMENT	INSIDE BACK COVER

GENERAL INFORMATION

1.1 INTRODUCTION

Your mower was built to the highest standards in the industry. However, the prolonged life and maximum efficiency of your mower depends on you following the operating, maintenance and adjustment instructions in this manual.

If additional information or service is needed, contact your Scag Power Equipment Dealer.

We encourage you to contact your authorized Scag Power Equipment dealer for repairs. All Scag dealers are informed of the latest methods to service this equipment and provide prompt and efficient service in the field or at their service shop. They carry a full line of Scag service parts.

- IMPORTANT -

The replacement of any part on this product by other than the manufacturer's authorized replacement part may adversely affect the performance, durability or safety of this product.

Use of other than original Scag replacement parts will void the warranty.

When ordering parts, always give the model and serial number of your mower. The serial number plate is located on the frame between the engine and seat where shown in Figure 1-1.

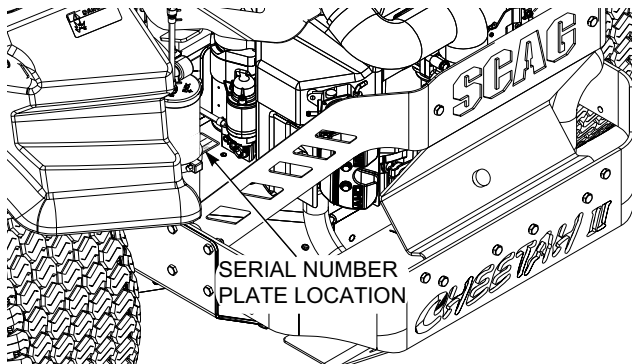

Figure 1-1. Mower Serial Number Plate Location

USE ONLY SCAG APPROVED ATTACHMENTS

AND ACCESSORIES.

Attachments and accessories manufactured by companies other than Scag Power Equipment are not approved for use on this machine. See Section 8, Paragraph 8-1. Be aware that using attachments with the mower may affect stability. Be sure to follow the directions found in the operator's manual.



WARNING

For pictorial clarity, some illustrations and figures in this manual may show shields, guards or plates open or removed. Under no circumstances should your mower be operated without these devices in place.

All information is based upon product information available at the time of approval for printing. Scag Power Equipment reserves the right to make changes at any time without notice and without incurring any obligation.











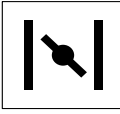
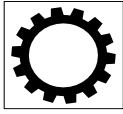

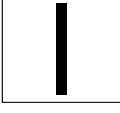
1.2 DIRECTION REFERENCE

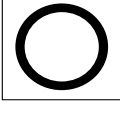
The "Right" and "Left", "Front" and "Rear" of the machine are referenced from the operator's right and left when seated in the normal operating position and facing the forward travel direction.

1.3 SERVICING THE ENGINE AND DRIVE TRAIN COMPONENTS

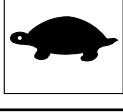
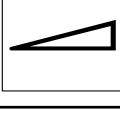
Details regarding the service and repair of the engine, hydraulic pumps and gearboxes are not covered in this manual; only routine maintenance and general service instructions are provided. For service of these components during the limited warranty period, it is important to contact your authorized Scag Power Equipment dealer or find a local authorized servicing agent of the component manufacturer. Any unauthorized work done on these components during the warranty period may void your warranty.

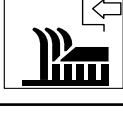
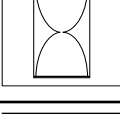
1.4 SYMBOLS

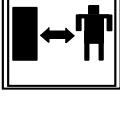
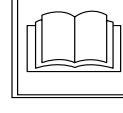
SYMBOL	DESCRIPTION	SYMBOL	DESCRIPTION
	Choke		Transmission
	Parking Brake		Spinning Blade
	On/Start		Spring Tension on Idler
	Off/Stop		Oil
	Falling Hazard		Thrown Object Hazard
	Fast		Slow
	Continuously Variable - Linear		Cutting Element - Basic Symbol
	Pinch Point		Cutting Element - Engage
	Hour meter/Elapsed Operating Hours		Cutting Element - Disengage
	Keep Bystanders Away		Read Operator's Manual

SAFETY INFORMATION

2.1 INTRODUCTION

Your mower is only as safe as the operator. Carelessness or operator error may result in serious bodily injury or death. Hazard control and accident prevention are dependent upon the awareness, concern, prudence, and proper training of the personnel involved in the operation, transport, maintenance and storage of the equipment. Make sure every operator is properly trained and thoroughly familiar with all of the controls before operating the mower. The owner/user can prevent and is responsible for accidents or injuries occurring to themselves, other people or property.

This product is capable of amputating hands and feet and throwing objects. Always follow all safety instructions on this product and in the manual to avoid personal injury or death.

READ THIS OPERATOR'S MANUAL AND USE THE QR CODE BELOW TO WATCH THE SAFETY VIDEO BEFORE ATTEMPTING TO START YOUR MOWER. MAKE SURE THAT EVERYONE KNOWS WHERE THE MANUAL IS LOCATED AND KEEP A RECORD OF EACH EMPLOYEE THAT HAS READ THE MANUAL.



Figure 2-1. SAFETY VIDEO QR CODE

A replacement manual is available from your authorized Scag Service Dealer or by contacting Scag Power Equipment, Service Department at P.O. Box 152, Mayville, WI 53050 or contact us via the Internet at www.scag.com. The manual for this machine can be downloaded by using the model and serial number or use the contact form to make your request. Please indicate the complete model and serial number of your Scag product when requesting replacement manuals.

2.2 SIGNAL WORDS



This symbol means “**Attention! Become Alert! Your Safety is Involved!**” The symbol is used with the following signal words to attract your attention to safety messages found on the decals on the machine and throughout this manual. The message that follows the symbol contains important information about safety. To avoid injury and possible death, carefully read the message! Be sure to fully understand the causes of possible injury or death.

SIGNAL WORD:

It is a distinctive word found on the safety decals on the machine and throughout this manual that alerts the viewer to the existence and relative degree of the hazard.

DANGER

The signal word “DANGER” denotes that an extremely hazardous situation exists on or near the machine that could result in high probability of death or irreparable injury if proper precautions are not taken.

WARNING

The signal word “WARNING” denotes that a hazard exists on or near the machine that can result in injury or death if proper precautions are not taken.

CAUTION

The signal word “CAUTION” is a reminder of safety practices on or near the machine that could result in personal injury if proper precautions are not taken.

Your safety and the safety of others depends significantly upon your knowledge and understanding of all correct operating practices and procedures of this machine.

2.3 BEFORE OPERATION CONSIDERATIONS

WARNING

Check all hydraulic connections for tightness. Inspect all hydraulic hoses and / or lines to insure they are in good condition before operating.

1. NEVER allow children to operate this riding mower. Do not allow adults to operate this machine without proper instructions.
2. Do not mow when children and/or others are present. Keep children out of the mowing area and in the watchful care of a responsible adult other than the operator. Be alert and turn machine off if a child enters the area.
3. DO NOT allow children to ride or play on the machine, it is not a toy.
4. Keep keys stored in a safe location when the mower is not in use; i.e. where they are inaccessible to children.
5. Clear the area to be mowed of objects that could be picked up and thrown by the cutter blades.
6. DO NOT carry passengers.
7. DO NOT operate the machine under the influence of alcohol or drugs.
8. If the operator(s) or mechanic(s) cannot read English, it is the owner's responsibility to explain this material to them.
9. DO NOT wear loose fitting clothing. Loose clothing, jewelry or long hair could get tangled in moving parts. Do not operate the machine wearing shorts; always wear adequate protective clothing including long pants. Wearing safety glasses, safety shoes and a helmet is advisable and is required by some local ordinances and insurance regulations.
10. Keep the machine and attachments in good operating condition. Keep all shields and safety devices in place. If a shield, safety device or decal is defective or damaged, repair or replace it before operating the machine.
11. Fuel is flammable; handle it with care. Fill the fuel tank outdoors. Never fill it indoors. Use a funnel or spout to prevent spillage. Clean up any spillage before starting the engine.
12. DO NOT start the engine until any spilled fuel has been cleaned up or has evaporated.
13. DO NOT add fuel to a running or hot engine. Allow the engine to cool for several minutes before adding fuel. Never fuel indoors or inside enclosed trailers.
14. See Section 7.5 ENGINE FUEL SYSTEM for fueling procedure.
15. Keep flammable objects (cigarettes, matches, etc.), open flames and sparks away from the fuel tank and fuel container. Use only approved containers.
16. Equipment must comply with the latest requirements per SAE J137 and/or ANSI/ASAE S279 when driven on public roads.

- NOTE -

If the mower is driven on public roads, it must comply with state and local ordinances as well as SAE J137 and/or ANSI / ASAE S279 requirements. Contact your local authorities for regulations and equipment requirements.

17. Do not operate without the side discharge chute installed and in the down position or with an optional grass catcher or mulch plate completely installed.
18. Check the blade mounting bolts at frequent intervals for proper tightness.
19. Make sure all hydraulic fluid connections are tight and all hydraulic hoses and lines are in good condition before starting the machine.
20. Be sure the interlock switches are functioning correctly.

WARNING

Always wear hearing protection. Operating this machine over prolonged periods of time can cause loss of hearing.

WARNING

This machine is equipped with an interlock system intended to protect the operator and others from injury. This is accomplished by preventing the engine from starting unless the deck drive is disengaged, the parking brake is on, the steering control levers are in the neutral position and the operator is in the seat. The system shuts off the engine if the operator leaves the seat with the deck drive engaged and/or the steering control levers are not in the neutral position and the parking brake is not engaged. Never operate equipment with the interlock system disconnected or malfunctioning.

2.4 TESTING THE SAFETY INTERLOCK SYSTEM

The safety interlock system should be tested each time before using the machine. If the safety interlock system does not operate as described below, contact your local Authorized Scag Power Equipment Dealer immediately to have the safety interlock system repaired.

1. Sit in the seat in the operating position, engage the parking brake, place the steering control levers in the neutral lock position, and engage the PTO switch to the ON (up) position. Try to start the engine; the engine should not start.
2. Sit in the seat in the operating position, engage the parking brake, move either of the steering control handles out of the neutral lock position, move the PTO switch to the OFF (down) position. Try to start the engine; the engine should not start. Repeat for the other steering control lever.
3. Sit in the seat in the operating position, disengage the parking brake, place the steering control levers in the neutral lock position, move the PTO switch to the OFF (down) position. Try to start the engine; the engine should not start.
4. Sit in the seat in the operating position, engage the parking brake, place the steering control levers in the neutral lock position, move the PTO switch to the OFF (down) position, and start the engine. With the engine running, release the parking brake and rise slightly off of the seat. The engine should shut off.

5. Sit in the seat in the operating position, engage the parking brake, place the steering control levers in the neutral lock position, move the PTO switch to the OFF (down) position, and start the engine. With the engine running, engage the PTO switch to the ON (up) position, and rise slightly off of the seat. The engine should shut off.
6. Sit in the seat in the operating position, engage the parking brake, place the steering control levers in the neutral lock position, move the PTO switch to the OFF (down) position, and start the engine. With the engine running, move either steering control lever out of the neutral lock position. The engine should shut off. Repeat for the other steering control lever.

2.5 OPERATION CONSIDERATIONS

1. Know the function of all controls and how to stop quickly.

WARNING

DO NOT operate on steep slopes. To check a slope, attempt to back up it (with the cutter deck down). If the machine can back up the slope without the wheels slipping, reduce speed and use extreme caution. Under no circumstances should the machine be operated on slopes greater than 15 degrees. See Figure 2-4, Page 11 to determine approximate slope or use a flat surface and an app on your cell phone. Reference the Safety Video using the QR Code in section 2.1. ALWAYS FOLLOW OSHA APPROVED OPERATION.

2. Reduce speed and exercise extreme caution on slopes and in sharp turns to prevent tipping or loss of control. Be especially cautious when changing directions on slopes.
3. Stay at least 2 cutting widths away from drop-offs, ditches, retaining walls, water, avoid any slope exceeding 15-degrees, and do not mow under trees on slopes with the roll bar down.
4. To prevent tipping or loss of control, start and stop smoothly, avoid unnecessary turns and travel at reduced speed.
5. If the operator were to lose steering control of the mower while operating, move both steering levers to the neutral position and immediately apply the parking brake. Inspect the machine and correct the problem before continuing to operate.

- When using any attachment, never direct the discharge of material toward bystanders or allow anyone near the machine while in operation.
- Before attempting to start the engine, with the operator in the seat, disengage power to the cutter deck, place the steering control levers in the neutral position and engage the parking brake.
- If the mower discharge ever plugs, shut off the engine, remove the ignition key, and wait for all movement to stop before removing the obstruction.

WARNING

DO NOT use your hand to dislodge the clogged discharge chute. Use a stick or other device to remove clogged material after the engine has stopped running and the blades have stopped turning.

- Be alert for holes, rocks, roots and other hidden hazards in the terrain. Keep away from any drop-offs. Beware of overhead obstructions (low limbs, etc.), underground obstacles (sprinklers, pipes, tree roots, etc.). Cautiously enter a new area. Be alert for hidden hazards.
- Disengage power to cutter deck before backing up. Do not mow in reverse unless absolutely necessary and then only after observation of the entire area behind the mower. If you must mow in reverse, maintain a constant lookout to the rear of the machine and mow slowly.
- DO NOT turn sharply. Use care when backing up.
- Disengage power to cutter deck before crossing roads, walks or gravel drives.
- Mow only in daylight or good artificial light.
- NEVER raise the deck with the blades engaged.
- Take all possible precautions when leaving the machine unattended, such as disengaging the mower, lowering the attachments, setting the parking brake, stopping the engine, and removing the key.
- Disengage power to the attachments when transporting or when not in use.
- The machine and attachments should be stopped and inspected for damage after striking a foreign object, and damage should be repaired before restarting and operating the machine.

CAUTION

Do not touch the engine or the muffler while the engine is running or immediately after stopping. These areas may be hot enough to cause a burn.

DANGER

DO NOT run the engine inside a building or a confined area without proper ventilation. Exhaust fumes are hazardous and contain carbon monoxide which can cause brain injury and death.

- Keep hands and feet away from cutter blades and moving parts. Contact can injure.
- Transport the mower using a heavy duty trailer or truck. Insure the trailer or truck has all of the necessary lighting and markings as required by laws, codes, and ordinances. Secure a trailer with a safety chain.
- Be cautious when loading and unloading onto trailers or trucks. Use only a full width ramp. Ramp angle should be no more than 15 degrees. Back up the ramp and drive down forward.
- When transporting the mower, make sure the park brake is engaged, the steering control levers are in the neutral position, the engine is off with the key removed, and the wheels have been blocked.
- Tie the mower down securely using straps, chains, cable, or ropes. Both front and rear straps must be directed down and outward from machine.
- Use care when approaching blind corners, shrubs, trees, or other objects that may obscure vision.
- NEVER leave the machine running unattended.

Section 2**2.6 ROLL-OVER PROTECTIVE STRUCTURE**** WARNING**

Reduce speed when turning, operating on slopes, slick or wet surfaces. Allow extra distance to stop.

Stay off of slopes too steep for safe operation. To check a slope, attempt to back up it (with the cutter deck down). If the machine can not back up the slope without the wheels slipping, do not operate the machine on this slope. Under no circumstances should the machine be operated on slopes greater than 15 degrees. See Figure 2-4, Page 11 to determine approximate slope or use a flat surface and an app on your cell phone. Reference the Safety Video using the QR Code in section 2.1.

Stay two cut widths away near drop-offs, ditches or embankments. The machine could suddenly roll over if a wheel goes over the edge or if the edge caves in.

Operate the machine smoothly, no sudden turns, starts or stops on a slope.

DO NOT lower the roll bar to mow under trees on slopes. If mowing under trees is required, always use a walk-behind mower or string trimmer.

NEVER tow on slopes. The weight of the towed equipment may cause loss of traction and loss of control.

DO NOT permit untrained personnel to operate the machine.

Be cautious when loading and unloading onto trailers or trucks.

Use only a full width ramp.

Ramp angle should be no more than 15 Degrees. See Figure 2-4, Page 11 to help determine approximate slope or use a flat surface and an app on your cell phone. Reference the Safety Video using the QR Code in section 2.1.

Back up the ramp and drive down forward.

This mower has been designed for good traction and stability under normal mowing conditions. However, caution must be used when traveling on slopes, especially when the grass is wet. Do not mow on wet grass. Wet grass reduces traction and steering control.

Any or all parts of the Roll-Over Protection Structure **MUST NOT** be removed. Failure to adhere to this guideline could result in injury or death.

FOLDABLE ROLL-OVER PROTECTION STRUCTURE** WARNING**

Keep the roll bar in the raised and locked position and the seat belt securely fastened during operation. Failure to do so could cause serious injury or loss of life.

Lower the roll bar only when absolutely necessary.

 WARNING

There is no roll-over protection when the roll bar is in the down position.

Lower the roll bar only when absolutely necessary.

Raise the roll bar as soon as clearance permits.

DO NOT wear the seat belt when the roll bar is in the down position.

ALWAYS wear seat belt when roll bar is in the up position.

Operate the machine smoothly, no sudden turns, starts or stops.

Check the area carefully before mowing for proper overhead clearance (i.e. branches, doorways, etc.).

DO NOT contact any overhead object with the roll bar.

1. To lower the roll bar, remove the hairpin cotter pins and remove the two (2) lock pins. See Figure 2-2.
2. Lower the roll bar to the folded position. See Figure 2-2.
3. To raise the roll bar, lift the bar to the upright position.
4. Install the two (2) lock pins through the holes and secure with the two (2) hairpin cotter pins. See Figure 2-2.

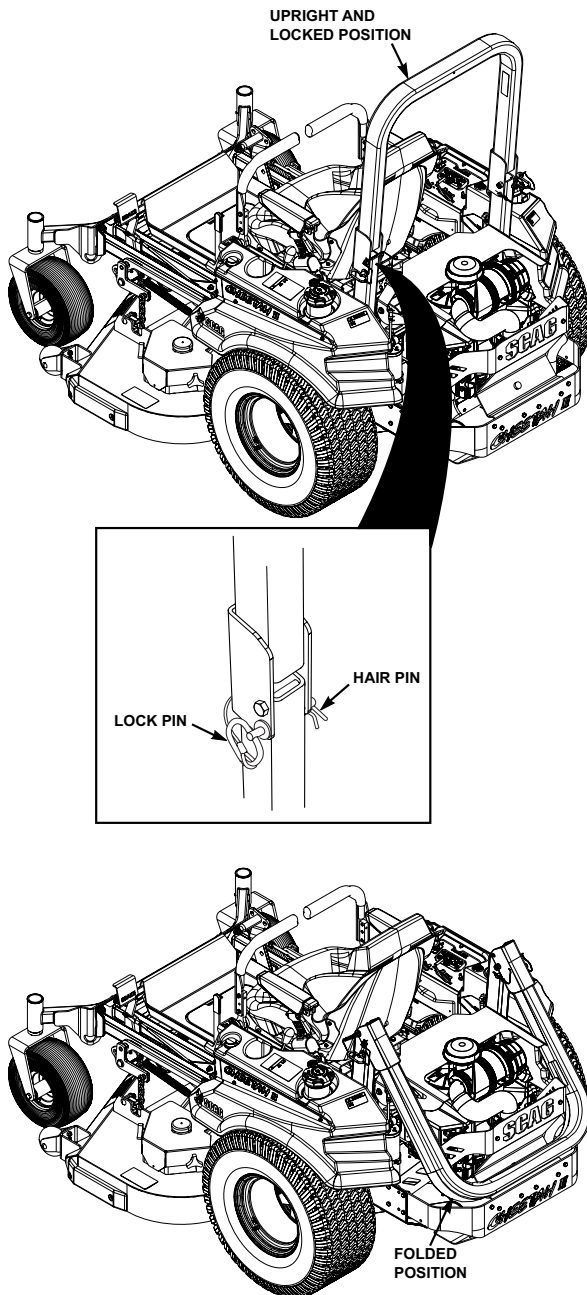

Figure 2-2. Foldable Roll-Over Protection Structure

The potential exposure of the seat belt to severe environmental conditions makes it crucial to inspect the seat belt system regularly.

It is recommended that the seat belt be inspected on a daily basis for signs of damage. Any seat belt system that shows cuts, fraying, extreme or unusual wear, significant discoloration due to UV exposure, dirt or stiffness, abrasion to the seat belt webbing, or damage to the buckle, latch plate, hardware or any other obvious problem should be replaced immediately.

WARNING

Failure to properly inspect and maintain the seat belt can cause serious injury or loss of life.

1. Check the full length of the seat belt webbing for cuts, wear, fraying, dirt and stiffness. See Figure 2-3.
2. Check the seat belt webbing in areas exposed to ultra violet rays from the sun or extreme dust or dirt. If the original color of the webbing in these areas is extremely faded and/or is packed with dirt, the physical strength of this webbing may have deteriorated. If this condition exists, replace the seat belt system.
3. Check the buckle and latch for proper operation and determine if the latch plate is excessively worn, deformed, or if the buckle is damaged or cracked. See Figure 2-3.
4. Be sure to confirm that the seat belt recoil latch is functioning properly.

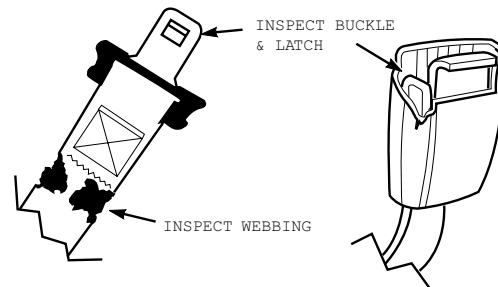

Figure 2-3. Seat Belt Inspection

2.7 MAINTENANCE CONSIDERATIONS AND STORAGE

1. Never make adjustments to the machine with the engine running unless specifically instructed to do so. If the engine is running, keep hands, feet, and clothing away from moving parts.
2. Disengage drives, lower implement, set parking brake, stop engine and remove key or disconnect spark plug wire to prevent accidental starting of the engine when servicing or adjusting the machine. Wait for all movement to stop before adjusting, cleaning or repairing.
3. Disconnect battery or remove spark plug wire before making any repairs. Disconnect the negative terminal first and the positive last. Reconnect the positive first and the negative last.
4. Keep all nuts, bolts and screws tight, to ensure the machine is in safe working condition. Check blade mounting bolts frequently to be sure they are tight.
5. Do not change the engine governor settings or over speed the engine. See the engine operator's manual for information on engine settings.
6. To reduce fire hazard, keep the cutting units, drives, muffler and engine free of grass, leaves, excessive grease, oil and dirt.
7. Park the machine on level ground and engage the parking brake.
8. NEVER allow untrained personnel to service the machine.
9. Use care when checking blades. Use a Blade Buddy (P/N 9212), wrap the blade(s) or wear gloves and USE CAUTION when servicing blades. Only replace blades. NEVER straighten or weld blades.
10. Keep all parts in good working condition. Replace all worn or damaged decals.
11. Use jack stands to support components when required.
12. Carefully release pressure from components with stored energy.



WARNING

Hydraulic fluid is under high pressure and can penetrate skin causing injury. If hydraulic fluid is injected into the skin, it must be surgically removed within a few hours by a doctor or gangrene may result.

Keep body and hands away from pinholes or nozzles that eject hydraulic fluid under high pressure. Use paper or cardboard and not hands to search for leaks.

Safely relieve all pressure from the hydraulic system by placing the control levers in the neutral lock position and shutting off the engine before performing any work on the hydraulic system.

If you need service on your hydraulic system, please see your authorized Scag dealer.

13. Let the engine cool before storing.
14. DO NOT store the machine near an open flame.
15. Shut off fuel while storing or transporting.
16. DO NOT store fuel near flames or drain indoors.
17. Charge batteries in an open, well ventilated area, away from spark and flames. Unplug charger before connecting or disconnecting from battery. Wear protective clothing and use insulated tools.

2.8 USING A SPARK ARRESTOR

The engine in this machine is not equipped with a spark arrestor muffler. It is in violation of California Public Resource Code Section 4442 to use or operate this engine on or near any forest covered, brush covered or grass covered land unless the exhaust system is equipped with a spark arrestor meeting any applicable local or state laws. Other states or federal areas may have similar laws. Check with your state or local authorities for regulations pertaining to these requirements.

2.9 SPARK IGNITION SYSTEM

This spark ignition system complies with Canadian ICES-002.

2.10 SAFETY AND INSTRUCTIONAL DECALS

⚠ DANGER

SPINNING BLADES
KEEP CLEAR
BLADE CONTACT & THROWN OBJECTS CAN INJURE

483407

483407

↑ FORWARD **R**

F **↓ REVERSE**

482100

⚠ WARNING

ROTATING BLADES AND BELTS

- Keep hands, feet & clothing clear
- Keep all guards in place
- Shut off engine & disengage blade clutch before servicing
- Use caution in directing discharge
- Read instruction manual before operating

DO NOT OPERATE UNLESS GRASS CATCHER, MULCHING KIT OR DISCHARGE CHUTE IS INSTALLED

483406

⚠ WARNING

SERIOUS INJURY OR DEATH MAY RESULT FROM MACHINE ROLLOVER

Failure to follow these instructions could result in serious injury or death

- Do not operate machine on steep slopes or near drop offs
- Avoid sharp and/or quick turns
- Do not exceed the machine weight rating on the ROPS
- Always use the seat belt
- Do not jump if machine flips while ROPS is fully extended and using seat belt
- If ROPS is foldable: Keep ROPS fully extended whenever possible

WHEN ROPS MUST BE DOWN: Do not use the seat belt. Drive with extra care.

483300

483300

IMPORTANT

Operation on slopes can be hazardous.

This machine was originally equipped with a Rollover Protection Device with a Roll Bar and Seat Belt.

See your dealer if either is missing or damaged.

483425

483425

START/DRIVE PROCEDURE

- Engage parking brake
- Disengage mower deck drive
- Move control handles to neutral lock position
- Start engine
- Release parking brake
- Select forward or reverse with hydro control handles

⚠ WARNING

AVOID SERIOUS INJURY OR DEATH

- Read the Operator's Manual
- Solicite etiquetas en español a un distribuidor Scag
- Operate only on slopes you can back up and never on slopes greater than 15 degrees
- If machine stops going uphill, stop blades and back down slowly
- Avoid sudden turns
- Do not mow when children or others are around
- Never carry children even with blades off
- Look down and behind before and while backing
- Keep safety devices (guards, shields, switches, etc.) in place and working
- Remove objects that could be thrown by the blades
- Trained operators only

483443

⚠ DANGER

Avoid injury from burns

- Shut off engine
- Allow to cool several minutes
- Remove cap slowly
- Do not overfill

Molded in Fuel Tank

⚠ WARNING

INSTALL BELT COVER BEFORE OPERATING MACHINE

READ OPERATOR'S MANUAL

483402

483402

⚠ WARNING

Operation of this equipment may create sparks that can start fires around dry vegetation. A spark arrester may be required. The operator should contact local fire agencies for laws or regulations relating to fire prevention requirements.

483900

(supplied with California models only)

IMPORTANT ADJUSTMENT PROCEDURES
READ OPERATORS MANUAL FOR MORE DETAILS
Check tire pressure: SC211-61/72 Drive tires-12 psi
Caster tires-Flat Free

HYDRAULIC FLUID LEVEL
Check hydraulic fluid level while fluid is cool. Fluid level should be at full cold line on tanks. Fill with 20W50 motor oil only.

FREE WHEEL OPERATION
To move machine without running engine, turn valve on LH & RH transaxles from RUN to BY-PASS. (see operator's manual)

NEUTRAL ADJUSTMENT

ALIGN TABS

To re-set neutral, have engine off and control levers in neutral. Remove rear wheels. Adjust linkage turnbuckle until tabs on transaxle align. Repeat for opposite side. If wheels still creep after adjustment, see an authorized Scag dealer.

TRACKING ADJUSTMENT

CONTROL LEVER
STOP BOLT

If machine pulls to right, adjust LH control stop bolt CW (inward) to slow left wheel down.
If machine pulls to left, adjust RH control stop bolt CW (inward) to slow right wheel down.

486612

486612

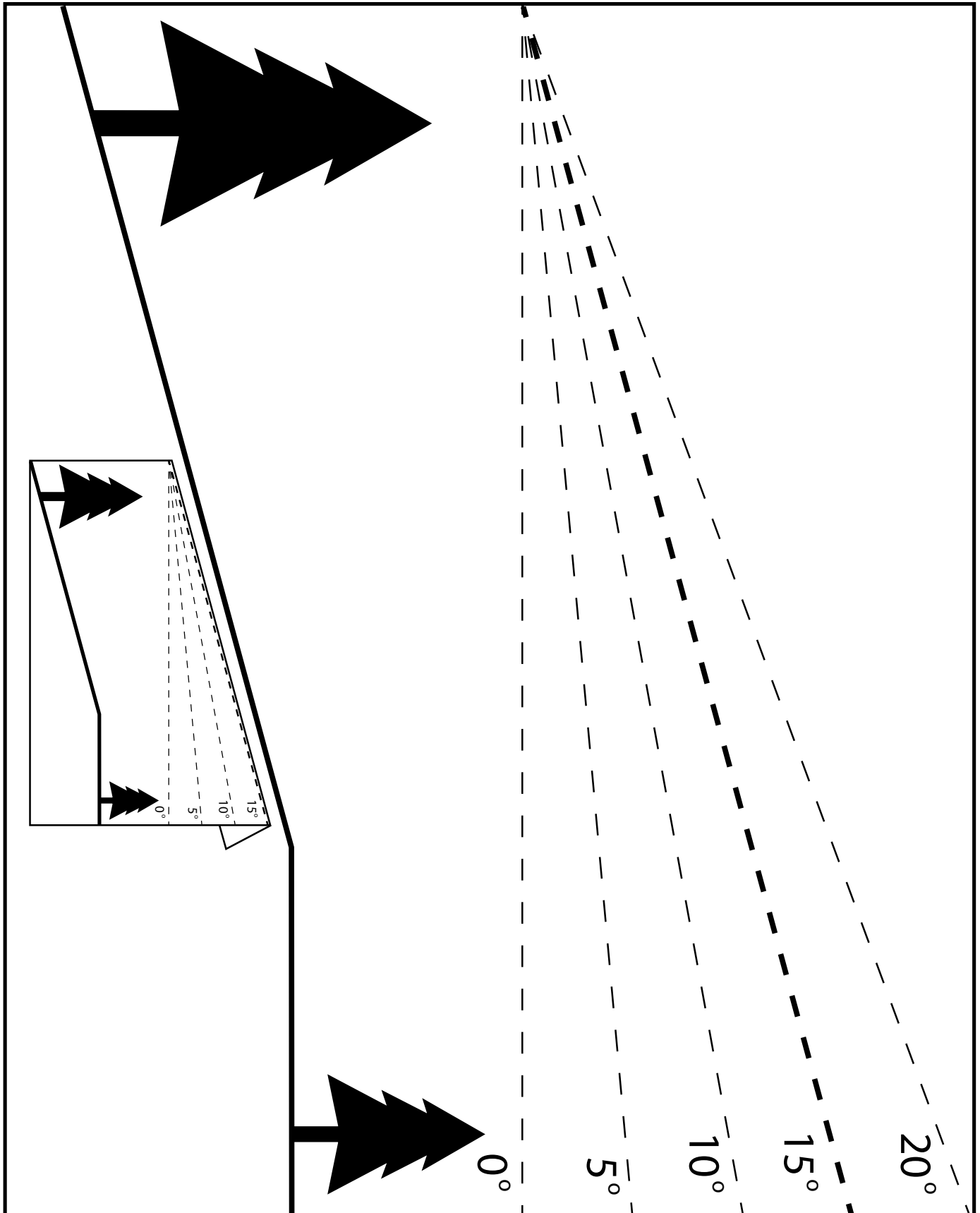

Figure 2-4. Slope Angle Graph

SPECIFICATIONS

3.1 ENGINE

General Type	Heavy Duty Industrial/Commercial Gasoline
Engine Model:	
Scag Model SCZII-61V-31FX, SCZII-61RD-31FX.....	Kawasaki FX921V
Scag Model SCZII-61V-38FX-EFI, SCZII-61RD-38FX-EFI, SCZII-72V-38FX-EFI.....	Kawasaki FX1000V
Scag Model SCZII-61V-37BV-EFI, SCZII-72V-37BV-EFI.....	Briggs & Stratton #61A7
Scag Model SCZII-61V-40BV-EFI, SCZII-72V-40BV-EFI.....	Briggs & Stratton #61G8
Scag Model SCZII-61V-38CV-EFI, SCZII-61RD-38CV-EFI, SCZII-72V-38CV-EFI.....	Kohler Command Pro ECV980
Displacement:	
Kawasaki 31FX (FX921)999cc
Kawasaki 38FX-EFI (FX1000).....	.999cc
Briggs & Stratton 37BV-EFI (#61A7).....	.993cc
Briggs & Stratton 40BV-EFI (#61G8).....	.993cc
Kohler 38CV-EFI (ECV980).....	.999cc
Type:	
Kawasaki (FX).....	4-Cycle, Air-Cooled, Naturally Aspirated Gasoline, OHV
Briggs & Stratton (#61A7).....	4-Cycle, Air-Cooled, Naturally Aspirated Gasoline, OHV
Briggs & Stratton (#61G8).....	4-Cycle, Air-Cooled, Naturally Aspirated Gasoline, OHV
Kohler (ECV980).....	4-Cycle, Air-Cooled, Naturally Aspirated Gasoline, OHV
Cylinders.....	2 with Cast Iron Sleeves
Governor.....	Mechanical Type with Variable Speed Control Set At 3600 RPM
Idle Speed	
Kawasaki.....	1550 RPM
Briggs & Stratton.....	1750 RPM
Kohler.....	1500 RPM
Carburation:	
Kawasaki (FX921V).....	Fixed Jet Downdraft Carburetor
Kawasaki (FX1000V).....	Electronic Fuel Injection
Briggs & Stratton (#61A7, #61G8).....	Electronic Fuel Injection
Kohler (ECV980).....	Electronic Fuel Injection
Fuel Pump:	
Kawasaki (FX).....	Mechanical with In-Line Fuel Filter
Kawasaki (FX1000V).....	Returnless High Pressure Fuel Module with Pulse Type Priming Pump
Briggs & Stratton.....	Electric with In-Line Fuel Filter
Kohler (ECV980).....	Mechanical with In-Line Fuel Filter
Fuel.....	Non-Leaded Gasoline with a Minimum Octane Rating of 87
Oil Pump.....	Full Pressure w/Full-Flow Filter
Starter.....	Electric Starting with Solenoid Shift
Belts.....	Kevlar cord. Self-adjusting, Self-tightening

3.2 ELECTRICAL

Battery	12 Volt
Charging System.....	Alternator
Charging Output:	
Kawasaki.....	12 Volt, 20 Amp
Briggs & Stratton.....	12 Volt, 20 Amp
System Polarity.....	Negative Ground
Interlock Switches.....	Seat, Neutral Control, Mower Engagement (PTO), Parking Brake
Instrument Panel.....	Ammeter, Key Switch, Throttle Lever, Manual Choke, PTO Switch and Fuses
Fuses.....	Two (2) 20 Amp

Section 3

3.3 POWER HEAD

Drive System	Hydraulic Drive with Two Hydro-Gear™ Integrated Zero-Turn Axles
Scag Model (SCZII)	Hydro-Gear™ ZT-5400
Steering/Travel Control	Twin Lever Fingertip Steering Control with Individual Control to Each Wheel with Gas Spring Dampers
Parking Brake	Foot Pedal Actuated Linkage to Brakes on Both Drive Wheel Axles
Wheels:	
(2) Front Caster - (61" & 72" Deck)	13 X 6.50 Four Ply, Flat Free
(2) Drive - (61" & 72" Deck)	24 x 12 x 12 Four-Ply Pneumatic Tubeless, Radius Edge
Tire Pressure:	
Front Caster	Flat Free
Drive	12 PSI
Fuel Tank	13-Gallon Total Capacity, (Dual) Seamless Roto-Low Perm. Tanks with Large Opening and Fuel Gauge
Seat	Padded, Thick Cushion with Tall Back Rest and Recline

Travel Speed	Low Range	High Range
Forward	0 up to 12 MPH	0 up to 16 MPH
Reverse	0 up to 5 MPH	0 up to 8 MPH

-NOTE- The machine will travel at 16 mph for transport purposes. For best cutting performance the forward travel speed should be set in low range and adjusted depending upon the cutting conditions.

3.4 CUTTER DECK

Type	Floating, Adjustable, Anti-Scalping, Hybrid Design Combines Out-Front and Belly-Mount Designs
Construction	Tri-Plate deck construction
	Top of deck consists of three steel plates totaling nearly 1/2" of steel.,7-gauge (3/16") deck skirt.
True Cutting Width:	
61V / 61RD	61" (155.0 cm)
72V	71.5" (181.6 cm)
Cutting Height Adjustment	Foot-Operated Lever Adjustment from Operator's Seat, 1-1/4" to 5" in 1/4" increments
Cutter Blades197 or .250 Thick, Milled Edge, Wear Resistant
61V / 61RD	Three (3) 21" blades
72V	Three (3) 24.5" blades
Blade Engagement	Electric Blade Engagement Clutch with Control Panel Switch Connected to the Cutter Deck through a belt.
Discharge Opening	Extra-Wide Discharge Opening with Spring-Loaded Discharge Chute and Turbo Baffle
Discharge Opening - 61RD	Extra-Wide Rear Discharge Opening
Discharge Chute	Black, Polypropylene (Plastic), Flexible
Discharge Chute - 61RD	Rubber Deflector
Spindles	Heavy-Duty 1-1/8" Top Dimension Spindle Shaft, Cast Housing, Taper Roller Bearing, Low Maintenance with Top Access Grease Fitting and Grease Overfill Relief Poppet
Spindle Pulleys	Split Steel with Easily Removed Taper Hubs
Cutter Deck Belts	B-Section with Kevlar Cord, Self-Adjusting, Self-Tightening
Electric Clutch Type	Ogura Heavy Duty PTO Clutch Brake

3.5 HYDRAULIC SYSTEM

Hydraulic Oil Filter	40 Micron
Hydraulic Reservoir	Nylon

3.6 WEIGHTS AND DIMENSIONS

	61V	61RD	72V
Length.....	85.5"	85.5"	91"
Tracking Width.....	55.25"	55.25"	55.25"
Overall Width w/chute down.....	73.5"	63.5"	83"
Overall Width w/chute up.....	62.75"	N/A	73.25"
Overall Height w/ROPS up.....	67"	67"	67"
Overall Height w/ROPS down.....	49.5"	49.5"	49.5"
Operating Weight..... 1.....	364-1377#	1364-1377#	1399-1412#

3.7 PRODUCTIVITY

	61V / 61RD	72V
Cutting Width.....	61"	72"
Acres Per Day.....	23.7	28

The preceding data will aid you in determining how many acres your Scag mower will cut per day. The chart is an estimate based on 8 hours per day cutting time at 6 MPH with a 20% allowance for overlap and turns.

NOTES

OPERATING INSTRUCTIONS

CAUTION

Do not attempt to operate this mower unless you have read this manual. Learn the location and purpose of all controls and instruments before you operate this mower.

Before operating the mower, familiarize yourself with all mower and engine controls. Knowing the location, function and operation of these controls is important for safe and efficient operation of the mower.

This machine is equipped with the Tiger Eye Advanced Monitoring System. With the key in the on position, before starting the engine, the lights for the Seat Indicator, PTO Indicator, Neutral Indicator and Park Brake Indicator should be illuminated. This indicates there is an operator in the seat, the PTO is off, steering levers are in neutral, and the parking brake is applied. When all the lights are illuminated, the key can be turned to the start position and the mower can be started. See Section 4.3 Safety Interlock System. If any of these indicator lights are not illuminated, the engine will be prevented from starting. If additional information or service is needed, contact your Scag Power Equipment Dealer.

4.1 TIGER EYE INSTRUMENT IDENTIFICATION

1. **Service Air Filter Indicator (Figure 4-1). Optional Accessory.** Indicates the condition of the engine air filter. Icon will display when it is time to change the air filter.
2. **Glow Plug Indicator (Figure 4-1). Used on Diesel Powered Units Only.** Indicator turns on when the key switch is turned to the PREHEAT position. Glow plugs must be preheated for 5 to 10 seconds before starting the engine.
3. **Oil Pressure Indicator (Figure 4-1). Used on Diesel Powered Units Only.** Indicates engine oil pressure. Reference the engine operator's manual for further information.
4. **Service Engine Indicator (Figure 4-1).** Indicates the maintenance reminder for the engine oil change. Has preset maintenance reminder and will start flashing scheduled maintenance 2 hours before preset time and continue flashing until 2 hours after. Automatically resets.
5. **Voltmeter Indicator (Figure 4-1).** Indicates the condition of the charging system. When the engine is running, in normal operating conditions, the bar graph should be in the 12 to 14 volt range.
6. **Seat Indicator (Figure 4-1).** Light will illuminate when the operator is in the seat engaging the seat switch.
7. **PTO Indicator (Figure 4-1).** Light will illuminate when the PTO (mower deck) switch is in the OFF position.
8. **Hour meter Indicator (Figure 4-1).** Indicates the number of hours the engine has been operated. It only operates when the engine is running. Will start flashing with the Service Engine Indicator at scheduled maintenance 2 hours before preset time and continue flashing until 2 hours after. Automatically resets.
9. **Neutral Indicator (Figure 4-1).** Light will illuminate when the steering control levers are in the neutral lock position.
10. **Park Brake Indicator (Figure 4-1).** Light will illuminate when the park brake is in the engaged (ON) position.
11. **Water Temperature Indicator (Figure 4-1). Used on Liquid Cooled Models Only.** Indicates the operating temperature of the engine. If the engine temperature exceeds the maximum preset value, the indicator will flash and the Park Brake, PTO, Seat and Neutral indicator lights will flash in an alternating pattern.

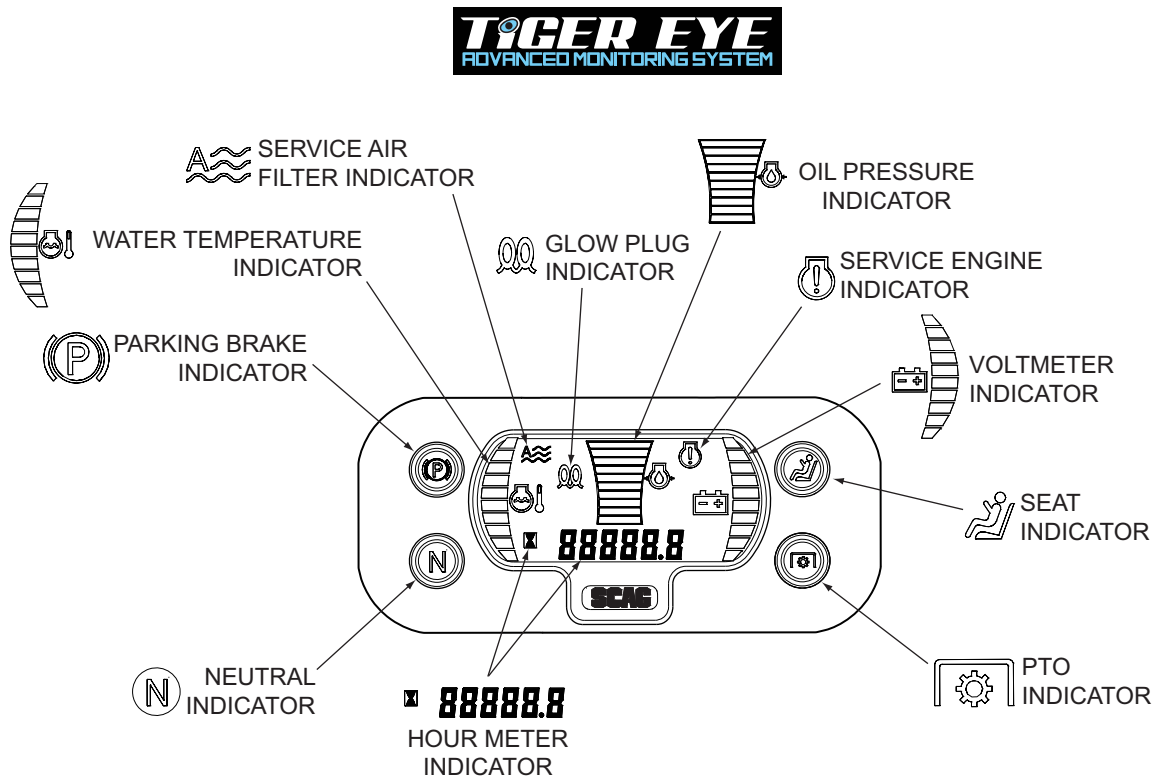

Figure 4-1. Tiger Eye Advanced Monitoring System

4.2 CONTROLS IDENTIFICATION

1. **Ignition Switch (Figure 4-3).** The ignition switch is used to start the engine and has three positions; OFF, ON, and START.
2. **Mower Deck Switch (Figure 4-3).** Used to engage and disengage the mower drive system. Pulling up on the switch will engage the deck drive. Pushing down on the switch will disengage the deck drive.
3. **Engine Choke Control (Figure 4-3).** Used to start a cold engine.
4. **Engine Throttle Control (Figure 4-3).** Used to control the engine speed. Pushing the lever forward increases engine speed. Pulling the lever back decreases engine speed. Full back position is the IDLE position. Full forward is the cutting position.
5. **Left Steering Control (Figure 4-3).** Used to control the mower's left wheel when traveling forward or reverse.
6. **Right Steering Control (Figure 4-3).** Used to control the mower's right wheel when traveling forward or reverse.
7. **Fuse Holders (Figure 4-3).** Two 20-amp fuses protect the mower's electrical system. To replace fuses, pull fuse out of the socket and install a new fuse.
8. **Parking Brake Control (Figure 4-3).** Used to engage and disengage the parking brakes. Push the brake pedal forward and pull the brake latch lever back to engage the parking brakes. Push the brake pedal fully forward, then release, to disengage the parking brakes.
9. **Fuel Tank Gauge (Figure 4-3).** Indicates the amount of fuel in the fuel tank.
10. **Dump Valve Control Levers (Figure 4-2).** Located on the hydraulic axles, used to "free-wheel" the mower. Rotating the levers clockwise until they stop allows the unit to move under hydraulic power. Rotating the levers counter-clockwise allows the mower to be moved by hand (free-wheeling).

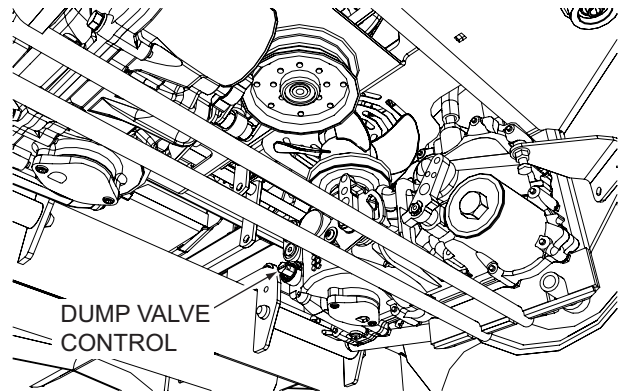

Figure 4-2. Dump Valve Control

11. **Deck Lift Foot Lever (Figure 4-3).** Used to raise and lower the cutter deck. Push full forward to lock in the transport position.
12. **Cutting Height Adjustment (Figure 4-3).** Used to set the cutter deck at the desired cutting height.
13. **Deck Release Lever (Figure 4-3).** Used to lock the cutter deck in the transport position. Push the foot pedal forward and pull back on the release lever to release the cutter deck for normal mowing.
14. **Speed Control Lever (Figure 4-3).** Used to select the mowers operating range. For the best performance while cutting, the LOW speed should be selected. HIGH speed should be selected for transport operation.
15. **Suspension Control Lever (Figure 4-3).** Used to select the optimum suspension rate based on the operator.
16. **Seat Belt (Figure 4-3).** Used to secure the operator. Seat belt must be worn at all times when the ROPS is in the upright and locked position.
17. **Seat Hold Down Release Latch (Figure 4-3).** Located behind the seat. Used to secure the seat in the operator's position. Release the latch to gain access under the seat.
18. **Check Engine Light (Figure 4-3WW).** Indicates the operation of the engine sensors on the Fuel Injection Engines (EFI). If a problem occurs with a sensor on the engine, the light will flash a code. See your authorized Scag Power Equipment dealer for diagnosis and repair.

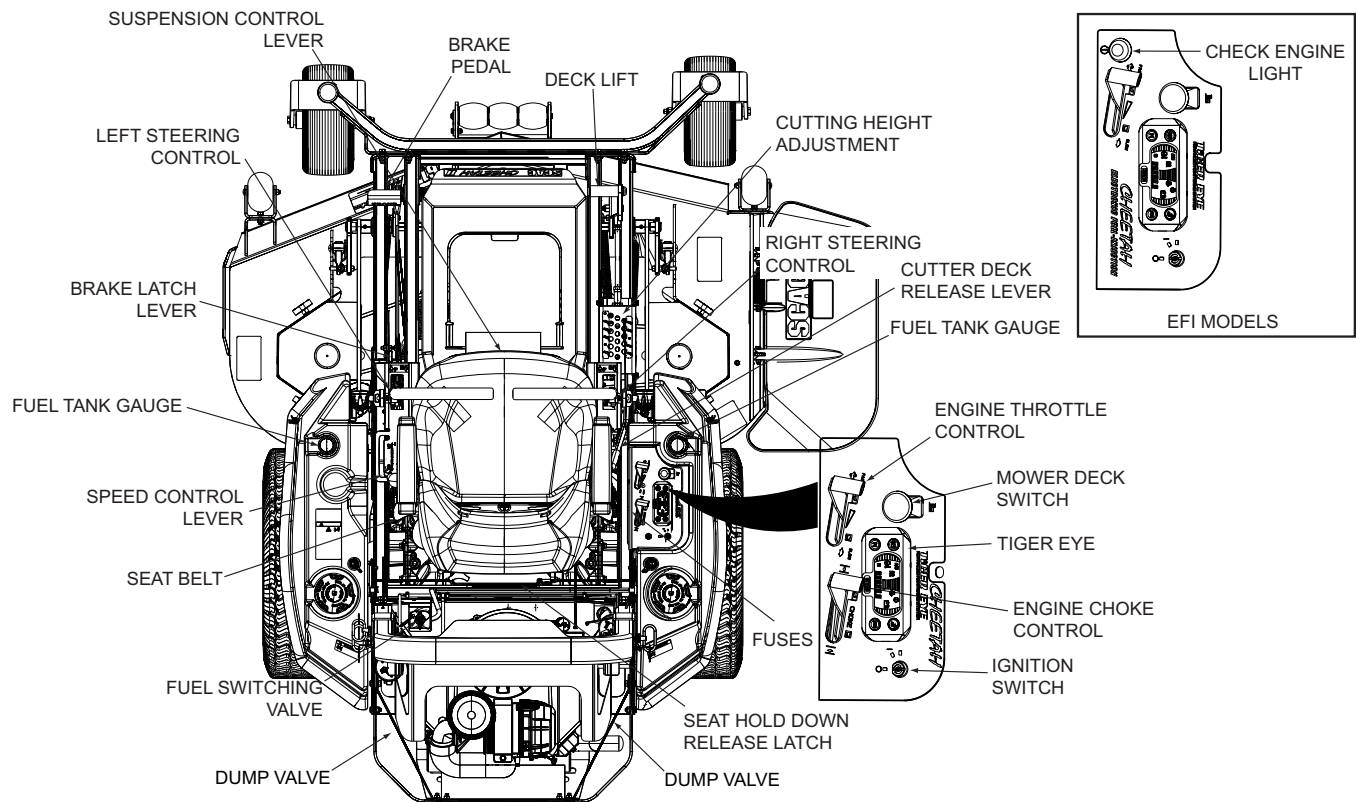

Figure 4-3. Controls and Instruments

4.3 SAFETY INTERLOCK SYSTEM

The mower is equipped with a safety interlock system that prevents the engine from starting unless the deck drive is disengaged, the parking brake is engaged, the steering control levers are in the neutral position and the operator is in the seat. The interlock system shuts off the engine if the operator leaves the seat with the steering control levers not in the neutral position and/or the cutter blades engaged and the parking brake not engaged.

WARNING

Never operate the mower with the interlock system disconnected or malfunctioning. Do not disengage or bypass any switch; injury to yourself and others or property damage could result.

4.4 TESTING THE SAFETY INTERLOCK SYSTEM

The safety interlock system should be tested each time before using the machine. If the safety interlock system does not operate as described below, contact your local Authorized Scag Power Equipment Dealer immediately to have the safety interlock system repaired.

1. Sit in the seat in the operating position, engage the parking brake, place the steering control levers in the neutral lock position, and engage the PTO switch to the ON (up) position. Try to start the engine; the engine should not start.
2. Sit in the seat in the operating position, engage the parking brake, move either of the steering control handles out of the neutral lock position, move the PTO switch to the OFF (down) position. Try to start the engine; the engine should not start. Repeat for the other steering control lever.
3. Sit in the seat in the operating position, disengage the parking brake, place the steering control levers in the neutral lock position, move the PTO switch to the OFF (down) position. Try to start the engine; the engine should not start.

4. Sit in the seat in the operating position, engage the parking brake, place the steering control levers in the neutral lock position, move the PTO switch to the OFF (down) position, and start the engine. With the engine running, release the parking brake and rise slightly off of the seat. The engine should shut off.
5. Sit in the seat in the operating position, engage the parking brake, place the steering control levers in the neutral lock position, move the PTO switch to the OFF (down) position, and start the engine. With the engine running, engage the PTO switch to the ON (up) position, and rise slightly off of the seat. The engine should shut off.
6. Sit in the seat in the operating position, engage the parking brake, place the steering control levers in the neutral lock position, move the PTO switch to the OFF (down) position, and start the engine. With the engine running, move either steering control lever out of the neutral lock position. The engine should shut off. Repeat for the other steering control lever.

4.5 INITIAL RUN-IN PROCEDURES

FIRST DAY OF USE OR APPROXIMATELY 20 HOURS

1. Check all belts for proper alignment and wear at 2, 4 and 8 hours.
2. Change the engine oil and oil filter after the first 20 hours of operation. (See Section 7.4.)
3. Check hydraulic oil level in reservoir. (See Section 7.3.)
4. Check for loose hardware. Tighten as needed.
5. Check interlock system for proper operation. (See Section 4.4.)
6. Check tire pressure. Adjust pressure if necessary. (See Section 7.10.)

4.6 STARTING THE ENGINE

CAUTION

DO NOT USE STARTING FLUIDS. Use of starting fluids in the air intake system may be potentially explosive or cause a “runaway” engine condition that could result in engine damage and/or personal injury.

1. Be sure the fuel shutoff valve, located behind the operator's seat, is fully open. (See Figure 4.2.)
2. Secure the ROPS in the upright and locked position.
3. Sit in the operator's seat, fasten seat belt and place the steering control levers in the neutral position.
4. Engage the parking brake.
5. Place the PTO switch in the disengaged position.
6. If the engine is cold, choke the engine as needed.
7. Move the engine throttle control to about half engine speed.
8. Turn the ignition key to the START position and release the key as soon as the engine starts. Do not hold the key in the START position for more than 15 seconds at a time. Allow at least 60 seconds between each cranking attempt to prevent overheating of the starter motor. Prolonged cranking can damage the starter motor and shorten battery life.
9. Allow engine to warm before operating the mower.

4.7 GROUND TRAVEL AND STEERING

- IMPORTANT -

If you are not familiar with the operation of a machine with lever steering and/or hydrostatic transmissions, the steering and ground speed operations should be learned and practiced in an open area, away from buildings, fences, or obstructions.

Learn the operation on flat ground before operating on slopes.

Start practicing with a slow engine speed and slow forward travel.

Learn to feather the steering controls to obtain a smooth operating action.

Practice operating the mower until you are comfortable with the controls before proceeding to mow.

Section 4**FORWARD TRAVEL**

To travel forward with the mower, disengage the parking brake, pull levers inward out of the neutral lock position and slowly push the steering control levers forward an equal distance. The further the steering control levers are pushed forward the greater the forward speed will be. To increase the speed, push the steering control levers further forward and to decrease the speed, pull the steering control levers back.

To stop the forward travel, pull the steering control levers back to the neutral position.

To steer the mower left while traveling forward, pull the left steering lever back. The further the lever is pulled back, the quicker the mower will turn left.

To steer the mower right while traveling forward, pull the right steering control lever back. The further the lever is pulled back, the quicker the mower will turn right.

- NOTE -

Smooth operation of the steering levers will produce smooth mower operation. While learning the operation of the steering controls, keep the travel speed low.

- IMPORTANT -

Do not travel forward over a curb. The mower will hang up on the curb. Raise the deck and travel backwards over the curb at a 45 degree angle. (See Section 4.2, items 11 - 13, on page 16 for cutter deck raising descriptions.)

REVERSE TRAVEL

CAUTION

Before backing up, observe the rear for persons and obstructions. Clear the area before backing up. Possible injury or property damage could occur.

To travel in reverse, pull levers inward out of the neutral lock position and pull both handles back. Keep the travel speed low while traveling in reverse.

- NOTE -

The mower may not travel straight in reverse. Slight adjustments may need to be made using the steering controls.

To steer left while traveling in reverse, allow the left steering control lever to move forward. The further the control is allowed to move forward, the quicker the mower will turn left.

To steer right while traveling in reverse, allow the right steering control lever to move forward. The further the control is allowed to move forward, the quicker the mower will turn right.

To stop the reverse travel, allow the steering control levers to return to the neutral position. If the mower is to be parked, place the handles in the neutral lock position and engage the parking brake.

CAUTION

Disengage power to the mower before backing up. Do not mow in reverse unless absolutely necessary and then only after observation of the entire area behind the mower.

4.8 ENGAGING THE DECK DRIVE (CUTTER BLADES)

1. Set the throttle at about 3/4 speed. Do not attempt to engage the deck drive at high speed as this shortens the electric clutch life — use only moderate engine speed when engaging the deck drive.



DANGER

ROTATING BLADES

NEVER PUT YOUR HANDS INTO THE DISCHARGE CHUTE FOR ANY REASON!

Shut off the engine and remove the key and only then use a stick or similar object to remove material if clogging has occurred.

2. Engage the deck drive by pulling out on the yellow switch, located on the instrument panel, to the engage position. See Figure 4-4.

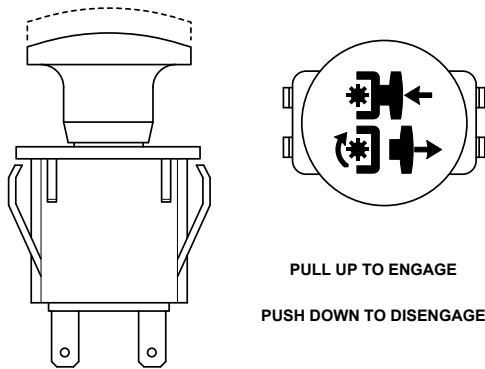



Figure 4-4. Cutter Engage Switch

- NOTE -

A squealing noise may be heard when engaging or disengaging the deck drive. It is caused by the electric clutch plates meshing as the mower comes up to speed. This is normal.

3. To disengage the deck drive, push the switch in to the disengage position.
4. Always operate the engine at full throttle to properly maintain cutting speed. If the engine starts to lug down, reduce the forward speed and allow the engine to operate at maximum RPM.

4.9 HILLSIDE OPERATION



WARNING

DO NOT operate on steep slopes. To check a slope, attempt to back up it (with the cutter deck down). If the machine can back up the slope without the wheels slipping, reduce speed and use extreme caution. Under no circumstances should the machine be operated on slopes greater than 15 degrees. See Figure 2-4, page 11 to determine approximate slope of area to be mowed. ALWAYS FOLLOW OSHA APPROVED OPERATION.

1. This mower has been designed for good traction and stability under normal mowing conditions. However, caution must be used when traveling on slopes, especially when the grass is wet. Wet grass reduces traction and steering control. The Roll-Over Protection System is standard equipment for this machine. See Section 2.6, page 7 of this manual for further details.
2. Stay at least 2 cutting widths away from drop-offs, ditches, retaining walls, water, avoid any slope exceeding 15-degrees, and do not mow under trees on slopes with the roll bar down.
3. To prevent tipping or loss of control, do not start or stop suddenly, avoid unnecessary turns and travel at reduced speed. If tires lose traction, disengage blades and proceed slowly off the slope.
4. Avoid sudden starts when mowing uphill. Sudden starts may cause the machine to tip backwards.
5. Loss of traction may occur when traveling down hill. Weight transfers to the front of the machine and may cause the drive wheels to slip causing loss of braking or steering.
6. Keep tires properly inflated.

4.10 PARKING THE MOWER

1. Park the machine on a flat, level surface only. Do not park the machine on an incline.
2. Place the steering control levers in the neutral position.
3. Disengage the cutter blades.
4. Slow the engine to idle speed.

Section 4

5. Engage the parking brake.
6. Turn the ignition key to the OFF position and remove the key.

4.11 AFTER OPERATION

1. Wash the entire mower after each use. Do not use high pressure spray or direct the spray onto electrical components.

- IMPORTANT -

Do not wash a hot or running engine. Cold water will damage the engine. Use compressed air to clean the engine if it is hot.

2. Keep the entire mower clean to inhibit serious heat damage to the engine or hydraulic oil circuit.
3. Check the drive belts for proper alignment and any signs of wear. Correct and adjust if necessary.

DANGER

To avoid injury from burns, allow the mower to cool before removing the fuel tank cap and refueling.

4. Check the tire pressure. Adjust pressure if necessary. (See Section 7.10.)

4.12 REMOVING CLOGGED MATERIAL

DANGER

ROTATING BLADES

NEVER PUT YOUR HANDS INTO THE DISCHARGE CHUTE FOR ANY REASON!

Shut off the engine and remove the key and only then use a stick or similar object to remove material if clogging has occurred.

1. If the discharge chute becomes clogged, shut off the engine and remove the ignition key. Using a stick or similar item, dislodge the clogged material. Then resume normal mowing.

4.13 MOVING MOWER WITH ENGINE STOPPED

To “free-wheel” or move the mower around without the engine running, rotate the dump valves counter-clockwise. See Figure 4-5. Disengage the parking brake and move the mower by hand. When the machine is in the desired position, engage the parking brake and rotate the valves clockwise until they stop. The dump valve levers must be returned to the DRIVE position to drive the mower.

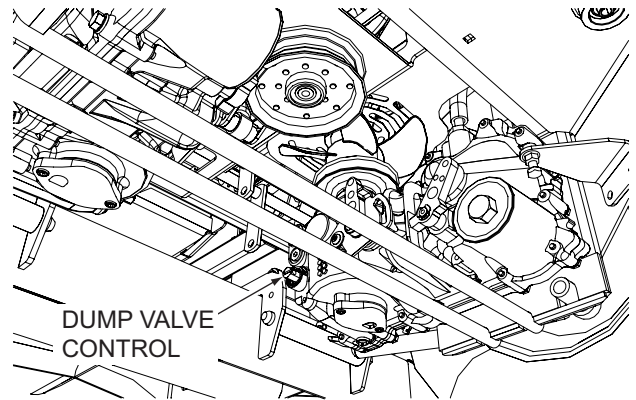

Figure 4-5. Dump Valve Control

4.14 RECOMMENDATIONS FOR MOWING

1. Do not mow with dull blades. A dull blade will tear grass, resulting in poor lawn appearance and reduced mowing power.

WARNING

DO NOT operate without Discharge Chute, Mulching Kit, or entire Grass Catcher properly installed.

2. The discharge chute must not be removed and must be kept in the lowest position to deflect grass clippings and thrown objects downward. Direct the side discharge away from sidewalks or streets to minimize cleanup of clippings. When mowing close to obstacles, direct the discharge away from the obstacles to reduce the chance of property damage by thrown objects. Do not mow when bystanders are present.
3. Cut grass when it is dry and not too tall. Do not cut grass too short (cut off 1/3 or less of existing grass for best appearance). Mow frequently.
4. Keep mower and discharge chute clean.

- For best overall cut performance, it is recommended to set the speed control lever in LOW while mowing. (See Section 4.18.)
- When mowing wet or tall grass, mow the grass twice. Set the speed control lever to LOW. Raise the mower to the highest setting for the first pass and then make a second pass to the desired height.
- Use a slow travel speed for trimming purposes.
- Operate the engine at full throttle for best cutting. Mowing with a lower RPM causes the mower to tear the grass. The engine is designed to be operated at full speed.
- Use the alternate stripe pattern for best lawn appearance. Vary the direction of the stripe each time the grass is mowed to avoid wear patterns in the grass.

4.15 ADJUSTING CUTTING HEIGHT

The mower deck can be adjusted from a height of 1-1/4 inch to 5 inches at 1/4-inch intervals. To adjust the cutting height:

WARNING

DO NOT adjust the cutting height with the mower blades rotating. Disengage the power to the cutter blades and then adjust cutting height.

- Disengage the power to the cutter blades.
- Push the cutting height adjustment foot pedal all the way forward using your right foot until it locks in place. See Figure 4-6.

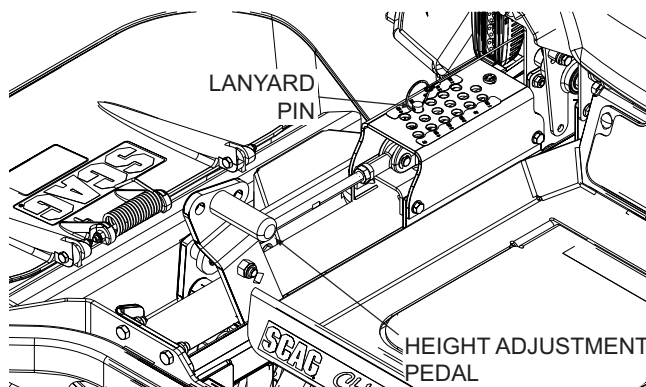

Figure 4-6. Adjusting Cutting Height

- Insert the lanyard pin into the cutting height index at the desired cutting height. Push forward on the deck lift foot lever, hold in place and pull back on the deck release lever. See Figure 4-7. Slowly release the foot pedal. A deck height decal is located on the cutting height index as an aid in adjusting the deck to the desired height. See Figure 4-6.

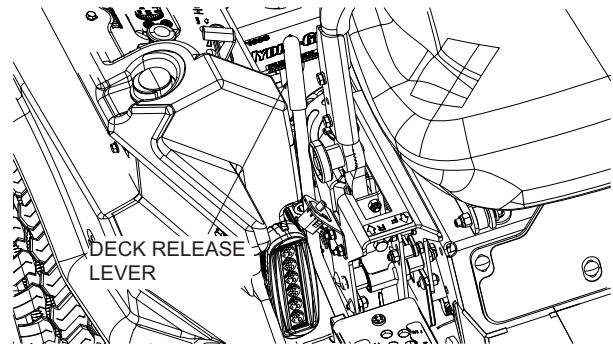

Figure 4-7. Deck Release Lever

4.16 ADJUSTING THE HEIGHT ADJUST PEDAL

- Position the seat to the desired location.
- While in the operator's position without the engine running, push down on the height adjust pedal to check for full function control.
- The height adjust pedal can be located in three (3) different positions for operator comfort and control. See Figure 4-8.

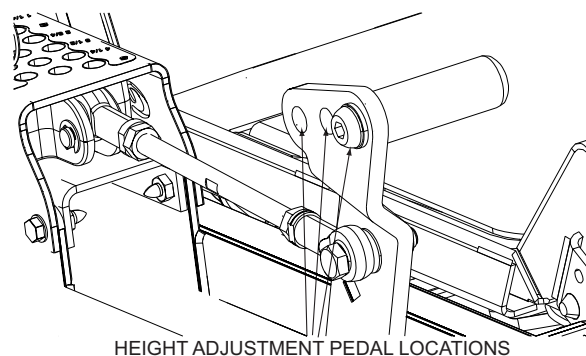

Figure 4-8. Height Adjust Pedal Locations

Section 4

4.17 ADJUSTING THE STEERING LEVERS

1. Position the seat to the desired location.
2. While in the operator's position without the engine running, move both steering levers forward and reverse to check for full function control and comfort.
3. If adjustment of the steering levers is needed, use the following instructions to adjust. See Figure 4-9.
 - A. Loosen the tension knob on the lever assembly.
 - B. Rotate the steering lever forward or backward to achieve the optimum operating position.
 - C. Tighten the tension knob and repeat on the opposite side.
 - D. While in the operator's position, bring the steering levers out of the neutral lock position and check to make sure both levers are even before operating.

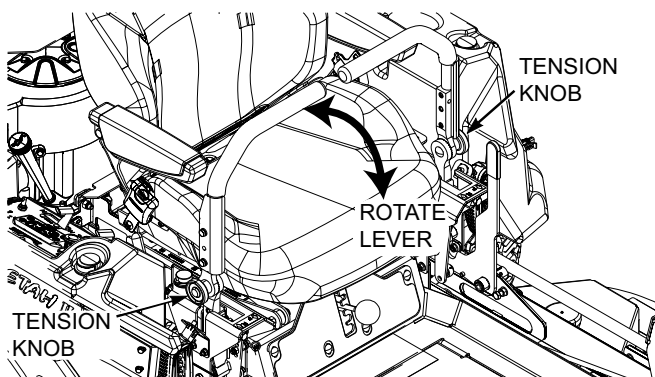

Figure 4-9. Adjusting Steering Levers

4. The control handle can also be adjusted in two different height positions. If necessary, remove the two bolts securing the control handle to the control lever. Install the handle in the desired position.

4.18 SETTING THE SPEED CONTROL

The speed control lever can be set in either LOW or HIGH range. Moving the speed control lever between LOW and HIGH range sets the maximum forward/reverse speed the machine can obtain during operation. See Figure 4-10.

Speed Control Selection Recommendations

LOW Range (Forward Travel Speed = 0 up to 12 mph)
- Recommended for best overall cutting performance in all conditions.

HIGH Range (Forward Travel Speed = 0 up to 16 mph)
- Recommended for transport. Although the machine is capable of engaging the mowing deck in HIGH Range, overall quality of cut may suffer. If the material being cut is sparse or dormant, HIGH Range can be selected to "knock down" tall weeds, seed heads, etc. However for best overall cut performance, it is recommended to select LOW Range for mowing.

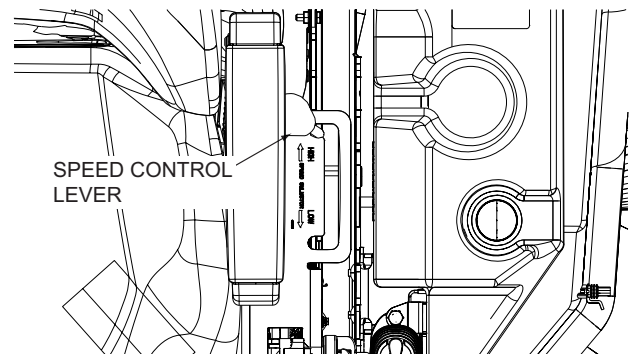

Figure 4-10. Speed Control Lever

4.19 ADJUSTING THE OPERATOR SUSPENSION PLATFORM

The operator suspension platform can be adjusted to optimize operator comfort and ride. Adjust the suspension rate by moving the suspension control lever down to increase (stiffen) or up to decrease (soften) the suspension shock rate. See Figure 4-11.

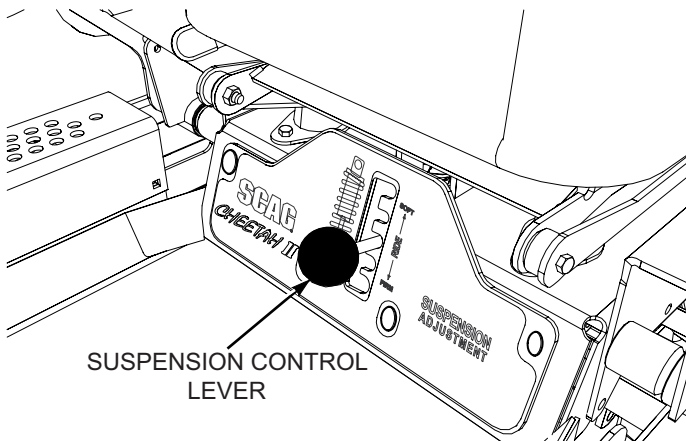
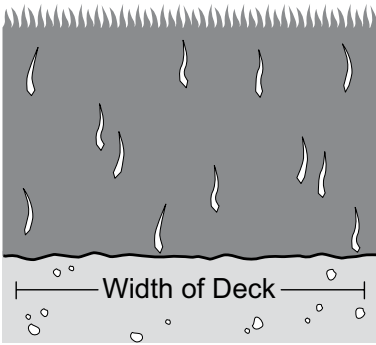
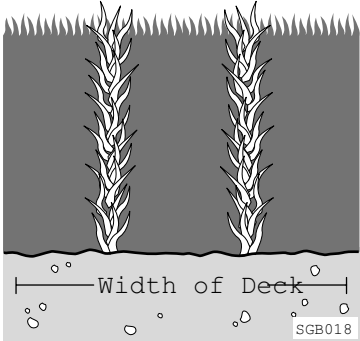
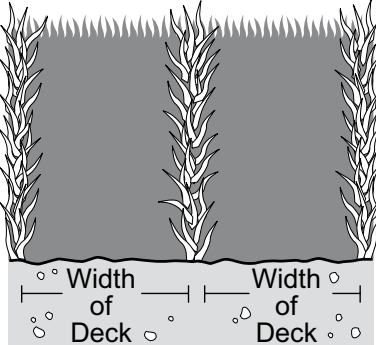

Figure 4-11. Operator Suspension Platform Adjustment

4.20 TOWING (OPTIONAL HITCH ACCESSORY)

1. NEVER allow children or others in or on towed equipment.
2. Tow only with a machine that has a hitch designed for towing. Do not attach towed equipment except at the hitch point.
3. Follow manufacturer's recommendations for weight limit for towed equipment. 250 lbs. maximum towing weight.
4. NEVER tow on slopes. The weight of the towed equipment may cause loss of traction and loss of control.
5. Travel slowly and allow extra distance to stop.
6. Zero-turning with a trailer attached could cause damage to the trailer or mower.

TROUBLESHOOTING CUTTING CONDITIONS

CONDITION	CAUSE	CURE
STRINGERS - OCCASIONAL BLADES OF UNCUT GRASS 	Low engine RPM	Run engine at full RPM
	Ground speed too fast	Slow speed to adjust for conditions
	Wet grass	Cut grass after it has dried out
	Dull blades, incorrect sharpening	Sharpen blades
	Deck plugged, grass accumulation	Clean underside of deck
	Belts slipping	Adjust belt tension
STREAKING - STRIPS OF UNCUT GRASS IN CUTTING PATH 	Dull, worn blades	Sharpen blades
	Incorrect blade sharpening	Sharpen blades
	Low engine RPM	Run engine at full RPM
	Belt slipping	Adjust belt tension
	Deck plugged, grass accumulation	Clean underside of deck
	Ground speed too fast	Slow speed to adjust for conditions
	Wet grass	Cut grass after it has dried out
	Bent blades	Replace blades
STREAKING - STRIPS OF UNCUT GRASS BETWEEN CUTTING PATHS 	Not enough overlapping between rows	Increase the overlap of each pass

TROUBLESHOOTING CUTTING CONDITIONS (CONT'D)

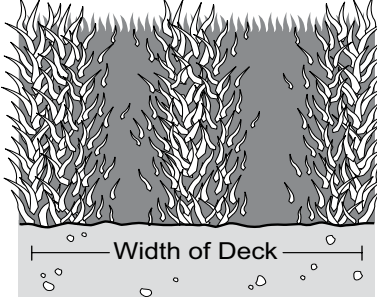
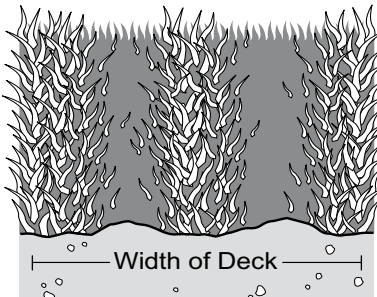
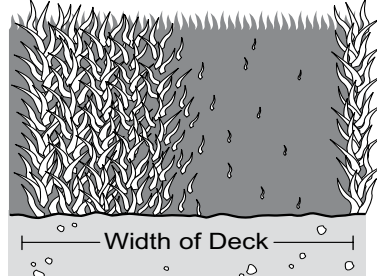
CONDITION	CAUSE	CURE
<p>UNEVEN CUT ON FLAT GROUND - WAVY HIGH-LOW APPEARANCE, SCALLOPED CUT, OR ROUGH CONTOUR</p> 	Lift worn from blade	Replace blade
	Blade upside down	Mount with cutting edge toward ground
	Deck plugged, grass accumulation	Clean underside of deck
	Too much blade angle (deck pitch)	Adjust pitch and level
	Deck mounted improperly	See your authorized SCAG dealer
	Bent spindle area	See your authorized SCAG dealer
	Dull blade	Sharpen blade
<p>UNEVEN CUT ON UNEVEN GROUND - WAVY APPEARANCE, HIGH-LOW SCALLOPED CUT, OR ROUGH CONTOUR</p> 	Uneven ground	May need to reduce ground speed, raise cutting height, and/or change direction of cut
<p>SLOPING RIDGE ACROSS WIDTH OF CUTTING PATH</p> 	Tire pressures not equal	Check and adjust tire pressure
	Wheels uneven	Check and adjust tire pressure
	Deck mounted incorrectly	See your authorized SCAG dealer
	Deck not level side-to-side	Check for level and correct

TROUBLESHOOTING CUTTING CONDITIONS (CONT'D)

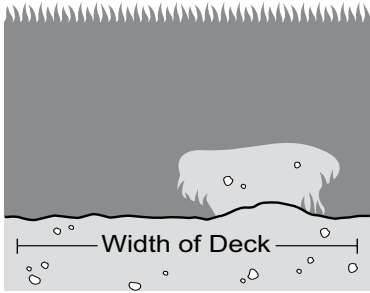
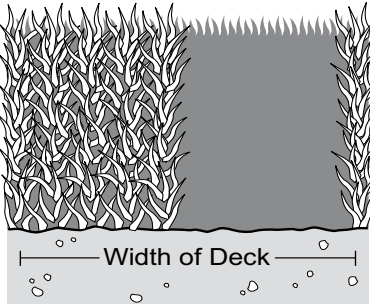
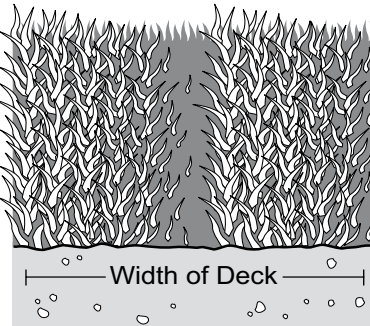
CONDITION	CAUSE	CURE
<p>SCALPING - BLADES HITTING DIRT OR CUTTING VERY CLOSE TO THE GROUND</p> 	Low tire pressures	Check and adjust pressures
	Ground speed too fast	Slow speed to adjust for conditions
	Cutting too low	May need to reduce ground speed, raise cutting height, change direction of cut, and/or change pitch and level
	Rough terrain	May need to reduce ground speed, raise cutting height, and/or change direction of cut
	Wet grass	Cut grass after it has dried out
<p>STEP CUT - RIDGE IN CENTER OF CUTTING PATH</p> 	Blades not mounted evenly	Adjust pitch and level
	Bent blade	Replace blade
	Internal spindle failure	See your authorized SCAG dealer
	Mounting of spindle incorrect	See your authorized SCAG dealer
<p>SLOPE CUT - SLOPING RIDGES ACROSS WIDTH OF CUTTING PATH</p> 	Bent spindle mounting area	See your authorized SCAG dealer
	Internal spindle failure	See your authorized SCAG dealer
	Bent deck housing	See your authorized SCAG dealer

ADJUSTMENTS

6.1 PARKING BRAKE ADJUSTMENT

WARNING

Do not operate the mower if the parking brake is not operable. Possible severe injury could result.

The parking brake linkage should be adjusted whenever the parking brake lever is placed in the "ENGAGE" position and the parking brake will allow the mower to move. If the following procedures do not allow you to engage the parking brake properly, contact your authorized Scag Power Equipment dealer for further brake adjustments.

1. Position a floor jack under the rear of the machine. Raise the machine and support it to prevent it from falling. Block the caster wheels to prevent the machine from moving.
2. With the brake in the engaged position, check the distance between the notch on the brake actuator rod and pivot bushing on the LH side of the machine. The distance should be 1/8". See Figure 6-1.
3. If the distance is not at the specified measurement, turn the adjustment nut on the brake actuator rod until the 1/8" measurement is achieved. See Figure 6-1.
4. Repeat steps 2-3 on the RH side of the machine.
5. Test the brake.

- NOTE -

If this procedure does not achieve proper brake adjustment, please contact your authorized Scag dealer.

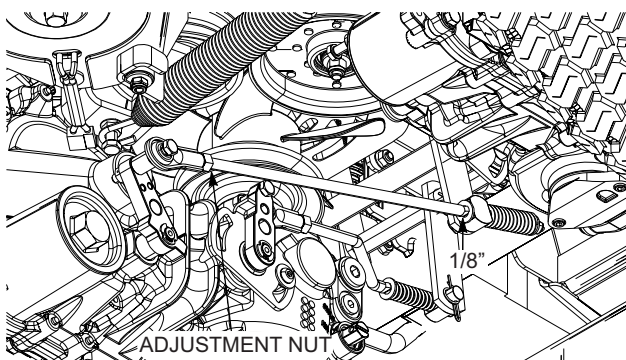

Figure 6-1. Brake Adjustment

6.2 TRAVEL ADJUSTMENTS

Neutral or tracking adjustments will need to be made if:

- A. The steering control levers are in the neutral position and the machine creeps forward or backward (Neutral Adjustment).
- B. The steering control levers are in the full forward position and the mower pulls to one side or the other when traveling in a forward direction (Tracking Adjustment).

NEUTRAL ADJUSTMENT

1. Be sure the dump valve levers are in the run position and the steering control levers are in the neutral lock position.
2. With an operator in the seat, start the engine and disengage the parking brake.
3. Run the engine at full operating speed and check if the machine creeps forward or backwards.
4. If the machine creeps either forward or backward, a neutral adjustment will need to be done.
5. Before making an adjustment, Position a floor jack under the rear of the machine. Raise the machine and support it to prevent it from falling. Block the caster wheels to prevent the machine from moving.
6. To adjust the RH side, make sure the control levers are in the neutral lock position. Then remove the wheel, loosen the jam nut on the control arm, and adjust the control rod until the control plates on the trans axle are centered in neutral. See Figure 6-2.

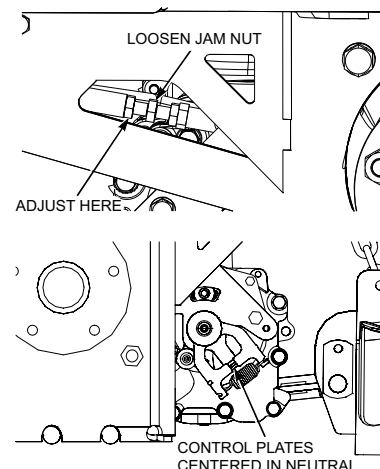

Figure 6-2. Steering Control Linkage Adjustment

Section 6

7. Tighten the jam nuts and repeat for the LH wheel. See Figure 6-2.
8. Operate and test the machine. Actuate the steering control levers forward and reverse several times and return them to the neutral position.
9. Check that the drive wheels remained in neutral and readjust if necessary.
10. Check that the steering control levers hit the stop before the pumps reach full stroke. Adjust as needed.

TRACKING ADJUSTMENT

CAUTION

Stop the engine and remove the key from the ignition before making any adjustments. Wait for all moving parts to come to a complete stop before beginning work.

CAUTION

The engine and drive unit can get hot during operation causing burn injuries. Allow engine and drive components to cool before making any adjustments.

- NOTE -

Before proceeding with this adjustment, be sure that the caster wheels turn plus pivot freely and that the tire pressure in the drive wheels is correct. If the tire pressure is not correct, the machine will pull to the side with the lower pressure.

1. If at full speed the mower pulls right, it is an indication that the left wheel is turning faster than the right wheel. To adjust this condition, proceed as follows:
 - A. Stop the machine and place the steering control levers in the neutral position. Turn the tracking adjustment bolt for the LH pump inward (clockwise). This will cause the control rod to stroke the LH pump less, slowing down the LH wheel. See Figure 6-3.

2. If at full speed the mower pulls left, it is an indication that the right wheel is turning faster than the left wheel. To adjust this condition, proceed as follows:
 - A. Stop the machine and place the steering control levers in the neutral position. Turn the tracking adjustment bolt for the RH pump inward (clockwise). This will cause the control rod to stroke the RH pump less, slowing down the RH wheel. See Figure 6-3.

- NOTE -

If after making the adjustment as outlined in step 2A, the machine creeps forward or backward, perform the neutral adjustment. See Neutral Adjustment on page 27.

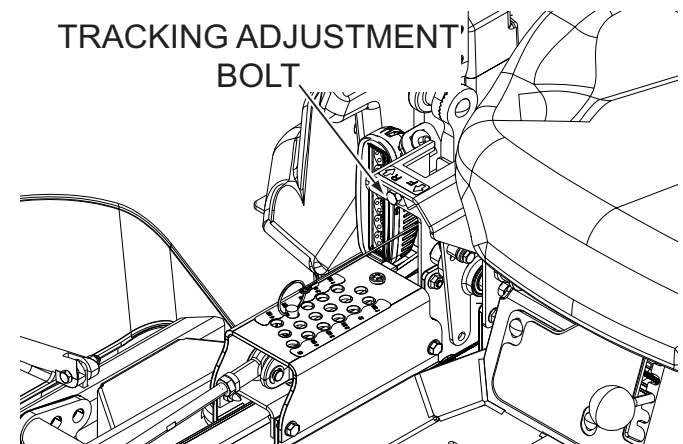

Figure 6-3. Tracking Adjustment

6.3 LOW / HIGH SPEED ADJUSTMENT

The LOW / HIGH speed linkage should be adjusted whenever the lever will not allow the mower to change speeds between LOW and HIGH range. If the following procedures do not allow you to change speeds properly, contact your authorized Scag Power Equipment dealer for further adjustments.

1. Position a floor jack under the rear of the machine. Raise the machine and support it to prevent it from falling. Block the caster wheels to prevent the machine from moving.
2. Position the speed control lever in LOW range.
3. Loosen the jam nut and remove the cotter pin securing the speed control linkage to the speed control rod. See Figure 6-4.
4. Adjust the speed control linkage until speed control arm on the RH axle is against the LOW range stop. See Figure 6-4.
5. Repeat steps for the LH axle.

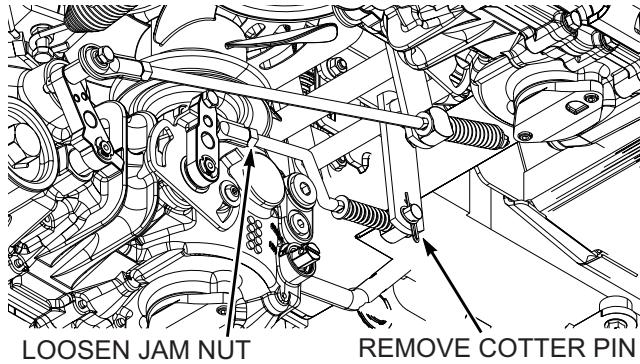

Figure 6-4. Speed Control Adjustment

6.4 THROTTLE CONTROL AND CHOKE ADJUSTMENTS

These adjustments must be performed by your authorized Scag Power Equipment dealer to ensure proper and efficient running of the engine. Should either need adjustment, contact your authorized Scag Power Equipment dealer.

6.5 BELT ADJUSTMENT

WARNING

Before removing any guards, shut the engine off and remove the ignition key.

All drive belts are spring loaded and self-tensioning, however after the first 2, 4, 8 and 10 hours of operation, the belts should be checked for proper alignment and wear. Thereafter, check the belts after every 40 hours of operation or weekly, whichever occurs first.

WARNING

If the pump drive belt fails, steering control will be lost which could result in serious injury or death. Replace the pump drive belt as needed or every 400 hours / 2 years, whichever occurs first.

6.6 BELT ALIGNMENT

Belt alignment is important for proper performance of your Scag mower. If you experience frequent belt wear or breakage, see your authorized Scag Power Equipment dealer for belt adjustment.

6.7 CUTTER DECK ADJUSTMENTS

Cutter deck level, pitch and height are set at the factory. However, if these adjustments should ever need to be made, the following procedures will aid in obtaining the proper cutter deck adjustment.

- NOTE -

Before proceeding with the cutter deck adjustments, be sure that all tires are properly inflated.

CUTTER DECK LEVEL

The cutter deck should be level from side-to-side for proper cutting performance. To check for level, be sure that the mower is on a flat, level surface, the tires are properly inflated and the cutter deck is set at the most common cutting height that you will use. On the RH side of the machine, check the distance from the top of the cutter deck to the floor. Next check the distance from the top of the cutter deck to the floor on the LH side of the machine. Both measurements should be the same. If the two measurements are different, the cutter deck level must be adjusted as follows:

1. If the cutter deck is lower on one side, loosen the elastic stop nuts securing the deck level links on the front and rear of the lower side. See Figure 6-5.

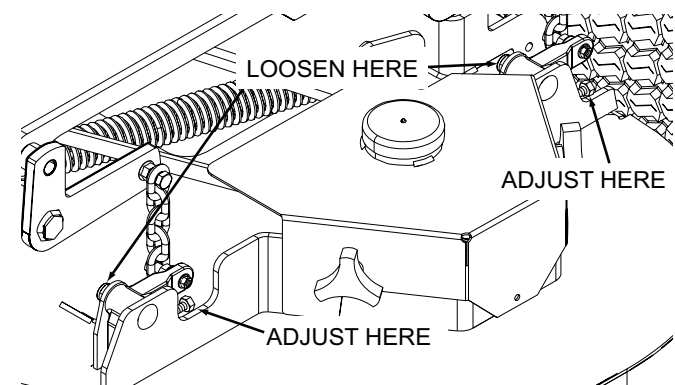

Figure 6-5. Cutter Deck Level Adjustment

2. Turn the adjustment bolts on the front and rear deck level links clockwise until the cutter deck is level between both sides. See Figure 6-5
3. Tighten the two (2) elastic stop nuts to secure the cutter deck in the proper position.

Section 6

CUTTER DECK PITCH

The pitch of the cutter deck should be equal between the front and rear of the cutter deck for proper cutting performance. To check for proper deck pitch, be sure that the mower is on a flat, level surface and the tires are properly inflated.

Check the distance from the top of the cutter deck to the floor at the rear RH side of the cutter deck directly behind the cutter deck hanging chains. Next check the distance from the top of the cutter deck to the floor at the front RH side of the cutter deck directly in front of the cutter deck hanging chains. The measurement at the front of the cutter deck should be the same as the rear of the deck. Make these measurements at the LH side of the cutter deck also. If the measurement at the front of the deck is not the same, the cutter deck pitch must be adjusted as follows:

1. Loosen the elastic stop nuts securing the deck level links on the front of the cutter deck on both sides. See Figure 6-6 and 6-7.

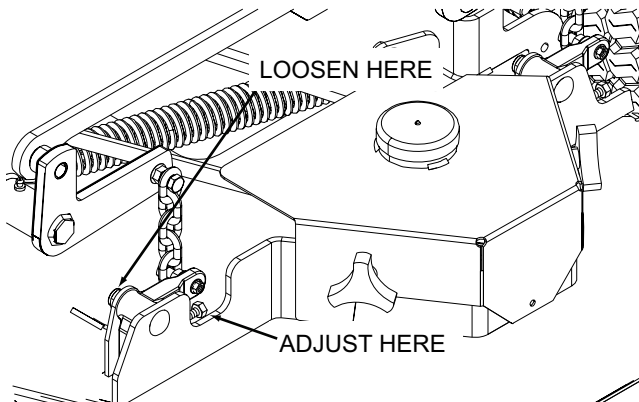

Figure 6-6. Cutter Deck Pitch Adjustment

2. Turn the adjustment bolts on both sides either clockwise to raise or counter-clockwise to lower the front of the cutter deck until the measurements are equal. Tighten the elastic stop nuts.

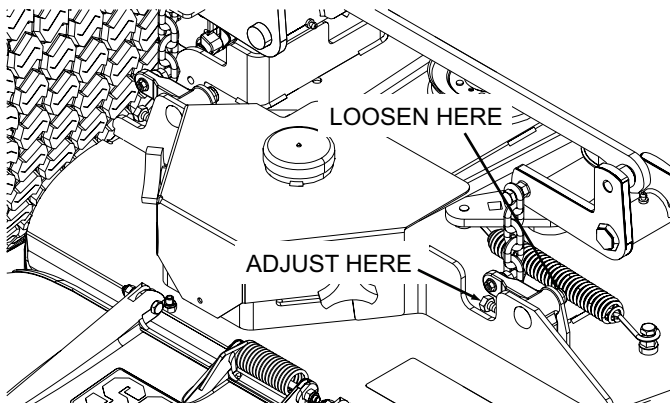

Figure 6-7. Cutter Deck Pitch Adjustment

- NOTE -

To prevent the cutter deck from teetering, all four (4) cutter deck hanging chains must have tension on them. If all four chains do not have tension on them and the deck teeters, you must re-adjust the cutter deck as outlined in the procedures above. All measurements should be taken from the top edge of the deck as the deck has an uneven bottom edge.

CUTTER DECK HEIGHT

The cutter deck height adjustment is made to ensure that the cutter deck is cutting at the height indicated on the cutting height index gauge. To check for proper deck height, be sure that the mower is on a flat, level surface and the tires are properly inflated.

1. Check the cutter deck cutting height by placing the lanyard pin in the 4-1/2" position on the cutting height index. Release the deck from the transport position and allow the deck to move to the 4-1/2" cutting height position.
2. Check the measurement from the floor to the cutter blade tip. If the measurement is not at 4-1/2", an adjustment can be made using the deck height control rod.
3. Loosen the jam nuts on both ends of the deck height control rod. See Figure 6-7.

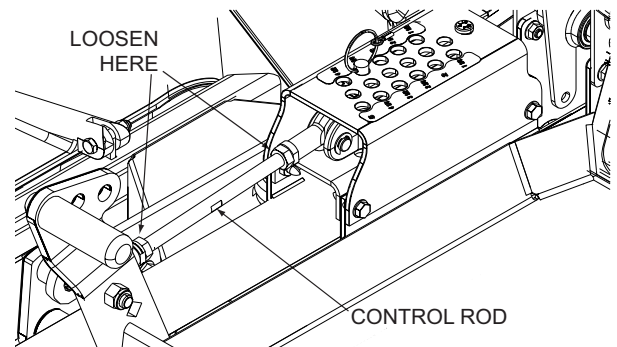

Figure 6-8. Cutter Deck Height Adjustment

4. Turn the control rod (See Figure 6-7) until the measurement from the floor to the cutter blade tip is at 4-1/2". Tighten the jam nuts on the control rod.

- NOTE -

If an adjustment had to be made, be sure that the cutter deck can easily be locked into the transport position.

6.8 CUSTOM-CUT BAFFLE ADJUSTMENT (EXCLUDES REAR DISCHARGE)

The Custom-Cut Baffle is designed to deliver optimum airflow and superior cutting performance in any type of grass. The Custom-Cut Baffle can be raised or lowered to precisely tailor the deck's performance for the type of grass being cut. The baffle can be set in seven (7) different positions for optimum performance.

A. 3-1/2" or 3-3/4" Position - (See Figure 6-9). For very tall, wiry or tough-to-cut grass.

B. 4" (factory setting), 4-1/4" or 4-1/2" Position - (See Figure 6-9). For general purpose cutting. This gives the best mix of cutting performance in all types of grass.

C. 4-3/4" or 5-1/4" Position - (See Figure 6-9). Placing the baffle in either the 4-3/4" or 5-1/4" setting will enhance fall cutting (leaf pickup) and reduce cutter deck "blowout".

To adjust the Custom-Cut Baffle height:

1. Place the cutter deck in the transport position.
2. Remove the hardware securing the Custom-Cut Baffle to the cutter deck.

- NOTE -

Hardware location used in the illustrations are for reference only. Location of hardware may vary depending on cutter deck size.

3. Move the Custom-Cut Baffle to desired position. See Figure 6-8.
4. Reinstall the mounting hardware. Torque hardware to 39 ft.-lbs.

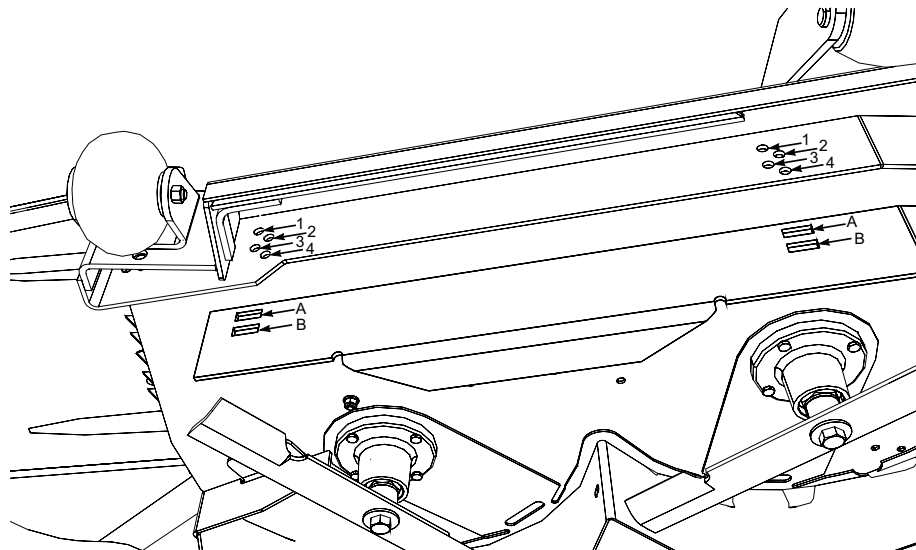

Custom-Cut Baffle Adjustment

Mounting Slot Selected	Mounting Hardware Location			
Slot "A"	Hole 1	Hole 2	Hole 3	Hole 4
Height (inches)	3-3/4"	4-1/4"	4-3/4"	5-1/4"
Slot "B"	Hole 2	Hole 3	Hole 4	
Height (inches)	3-1/2"	4"	4-1/2"	

Figure 6-9. 7-Position Custom-Cut Baffle Adjustment

Section 6

6.9 ADJUSTING THE STEERING DAMPERS

The steering dampener adjustment can be made to increase or decrease the dampening affect for smooth, precise steering control. There are three locations on the steering control levers that allow the operator to adjust the dampening affect of the steering control based on cutting conditions.

1. **Top Mounting Location (Figure 6-10).** Used for the highest dampening affect on the steering controls.
2. **Middle Mounting Location (Figure 6-10).** Used for average dampening affect on the steering controls.
3. **Bottom Mounting Location (Figure 6-10).** Used for the lowest dampening affect on the steering controls.

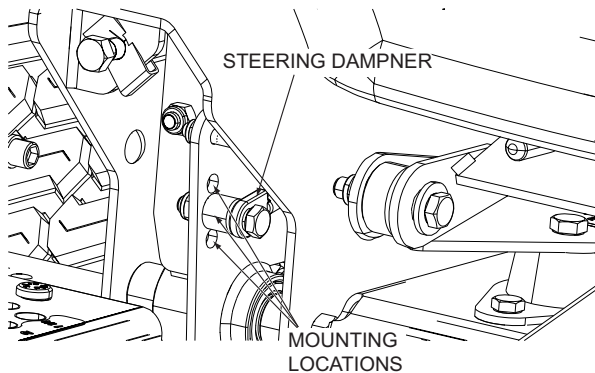

Figure 6-10. Steering Dampener Adjustment

6.10 ELECTRIC CLUTCH ADJUSTMENT

The electric clutch serves two functions in the operation of the mower. In addition to starting and stopping the power flow to the cutter blades, the clutch also acts as a brake to assist in stopping blade rotation when the PTO is switched off or the operator presence circuit is interrupted.

When the clutch is disengaged, the air gap between the armature and rotor must be adjusted to fifteen thousandths of an inch, 0.015, for proper operation. The air gap adjustment is made at three bolts on the clutch. There are three inspection windows, one next to each adjusting bolt. See Figure 6-10.

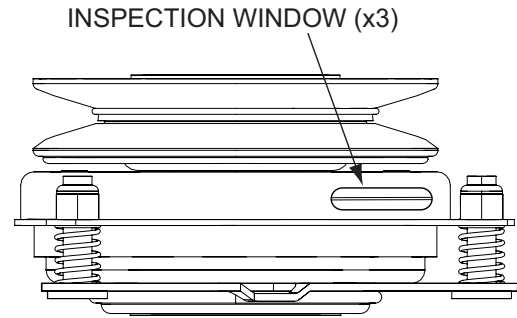

Figure 6-11. Clutch Air Gap Adjustment

1. Locate the inspection windows on the clutch.
2. Place a 0.015 feeler gauge in the slot between the rotor and the armature.
3. Tighten or loosen the adjusting bolt as needed to achieve the 0.015 inch air gap. See Figure 6-11. Perform this operation at all three inspection windows.

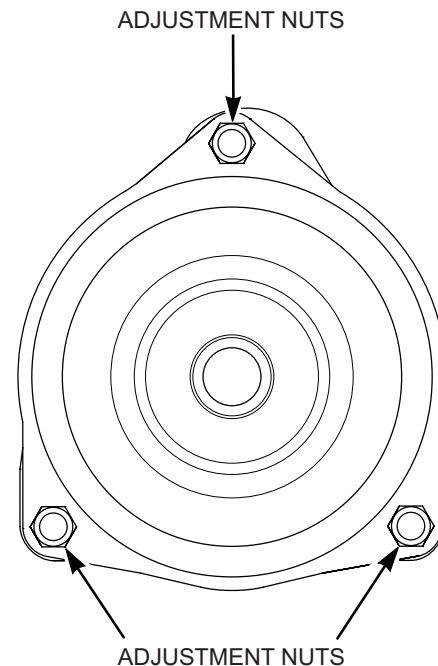

Figure 6-12. Clutch Air Gap Adjustment

This adjustment should be done every 500 hours of operation or annually, whichever comes first. In cases where the machine is heavily used, air gap settings should be checked more often.

If the air gap is too narrow, the clutch armature may drag when disengaged, resulting in premature failure.

If the air gap is too wide, the clutch may be slow to engage as the magnet must pull the armature in from a greater distance.

MAINTENANCE

7.1 MAINTENANCE CHART - RECOMMENDED SERVICE INTERVALS

HOURS							PROCEDURE	COMMENTS
BREAK-IN (FIRST 10)	8	20	40	100	200	500		
X							Check all hardware for tightness	
X							Check hydraulic oil level	See Section 7.3
X							Check all belts for proper alignment	See Section 7.8
X							Change engine oil and filter	See Section 7.4
	X						Check hydraulic fittings and hoses for leaks	Use extreme caution when checking the hydraulic hoses. See Section 2.7
	X						Check engine oil level	See Section 7.4
	X						*Clean mower	See Section 7.11
	X						Check condition of blades	See Section 7.9
	X						Apply grease to fittings	See Section 7.2
	X						Check tire pressure	See Section 7.10
	X						Inspect seat belt for wear or damage	See Section 2.6
	X						Check the operator interlock system	See Section 4.3
		X					Change engine oil and filter	See Section 7.4
			X				Check battery and clean battery posts and cables	See Section 7.7
			X				Inspect pump drive belt. Replace every 400 hours or 2 years, whichever occurs first	See Section 6.5 & 7.8
			X				Check belts for proper alignment	See Section 7.8
				X			Check conditions of fuel lines	
				X			Apply grease to fittings	See Section 7.2
				X			Change engine oil	See Section 7.4
				X			Drain hydraulic system and replace hydraulic oil (initial change)	Use SAE 20W50 Motor Oil. See Section 7.3
				X			*Clean air cleaner element	See Section 7.6

* Perform these maintenance procedures more frequently under extreme dusty or dirty conditions

MAINTENANCE CHART - RECOMMENDED SERVICE INTERVALS (CONT'D)

HOURS						PROCEDURE	COMMENTS
BREAK-IN (FIRST 10)	8	40	100	200	500		
				X		Apply grease to fittings	See Section 7.2
				X		Check hardware for tightness	
				X		Change engine oil filter	See Section 7.4
				X		Check hydraulic oil level	See Section 7.3
					X	Replace engine fuel filter	See Section 7.5
					X	Drain hydraulic system and replace hydraulic oil	Use SAE 20W50 Motor Oil. See Section 7.3
					X	Replace hydraulic oil filter	See Section 7.3
					X	Adjust electric PTO clutch	See Section 6.10

7.2 LUBRICATION





GREASE FITTING LUBRICATION CHART (SEE FIGURE 7-1)

LOCATION	LUBRICATION INTERVAL	LUBRICANT	NO. OF PLACES
1 Caster Wheel Pivot *	500 Hours/Yearly	Chassis Grease	2
2 Caster Wheel Bearings	100 Hours/Monthly	Chassis Grease	2
3 LOW / HIGH Speed Actuator	200 Hours/Monthly	Chassis Grease	2
4 Cutter Deck Belcranks	100 Hours/Bi-Weekly	Chassis Grease	4
5 Cutter Deck Pusharms	100 Hours/Bi-Weekly	Chassis Grease	2
6 Cutter Deck Spindle	40 Hours/Weekly	Spindle Grease	3

+ Compatible Greases: Scag Premium Chassis Grease p/n 486257
 Scag Premium Spindle Grease p/n 486258

* PROCEDURE: Remove grease cap, part number 484195. Remove plug, part number 482028-01, and install grease zerk. Apply grease to the fitting until new grease appears at the top of the caster extension. Remove the grease zerk and reinstall the plug. Reinstall the grease cap. Special tool, part number 47007, is recommended for use in the installation of the grease cap.

GREASE FITTING LUBRICATION Lubricant Interval

-  Spindle Grease
(40 Hours/Weekly)
-  Chassis Grease
(100 Hours/Bi-monthly)
-  Chassis Grease
(200 Hours/Monthly)
-  Chassis Grease
(500 Hours/Yearly)

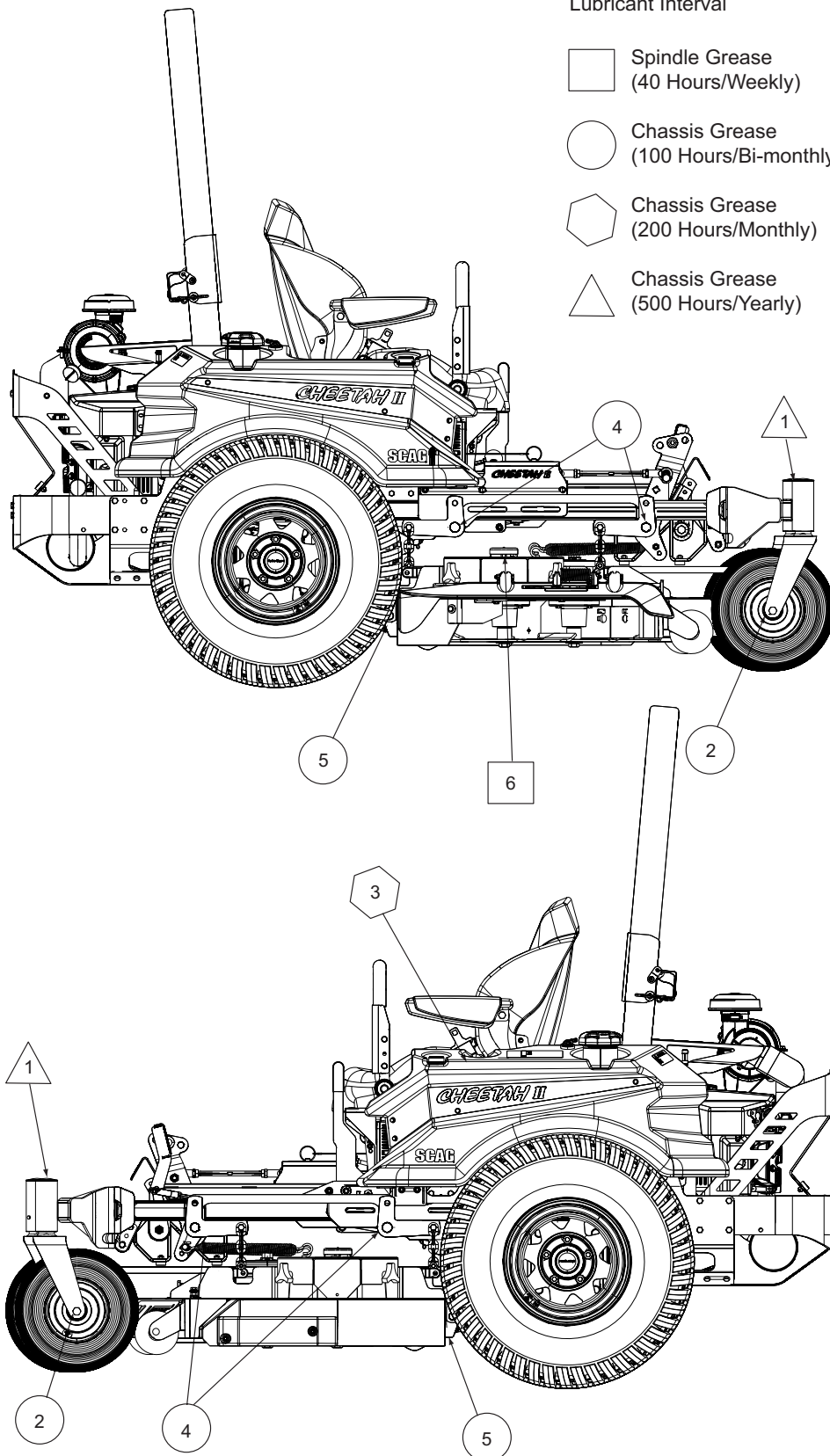

Figure 7-1. Lubrication Fitting Points

Section 7

7.3 HYDRAULIC SYSTEM

A. CHECKING HYDRAULIC OIL LEVEL

The hydraulic oil level of **both** expansion tanks should be checked after the first 10 hours of operation. Thereafter, check the oil after every 200 hours of machine operation or monthly, whichever occurs first.

- IMPORTANT -

If the oil level is consistently low, check for leaks and correct immediately.

1. Wipe dirt and contaminants from around the hydraulic level indicator window.
2. Visually check the level of hydraulic oil. Hydraulic oil must be within the center of the wide portion of the indicator window when the machine is cold. See Figure 7-2. If the fluid is low, add 20W50 oil (Scag p/n 486255 - 1 Quart or p/n 486254 - 1 Gallon). DO NOT overfill; (overfilling the oil reservoir may cause oil seepage around the cap area).

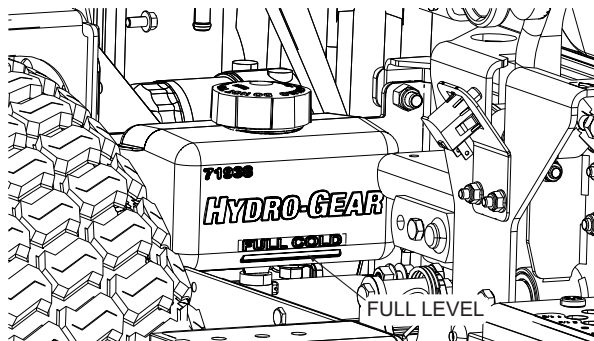

Figure 7-2. Hydraulic Oil Reservoir

B. CHANGING HYDRAULIC OIL AND FILTER

The hydraulic oil should be changed after the first 100 hours of operation. Thereafter, the hydraulic oil should be changed every 500 hours or annually, whichever occurs first. The oil should also be changed if the color of the fluid has become black or milky. A black color and/or a rancid odor usually indicates possible overheating of the oil, and a milky color usually indicates water in the hydraulic oil.

- IMPORTANT -

The hydraulic oil should be changed if you notice the presence of water or a rancid odor to the hydraulic oil.

1. Park the mower on a level surface and stop the engine.
2. Position a floor jack under the rear of the machine. Raise the machine and support it to prevent it from falling. Block the caster wheels to prevent the machine from moving.
3. Place a suitable container (capable of holding 6 quarts) under the RH hydraulic axle assembly. Remove the cover over the hydraulic reservoir located on the LH fuel tank. Remove the fill cap from the reservoir and the drain plug from the bottom of the RH hydraulic axle assembly. See Figure 7-3. Allow the fluid to drain into the container and properly discard it.

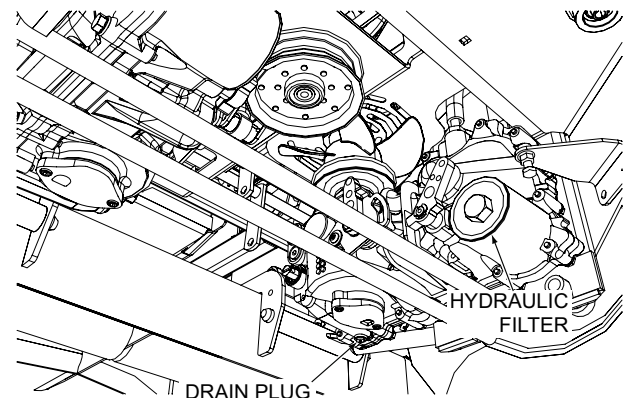
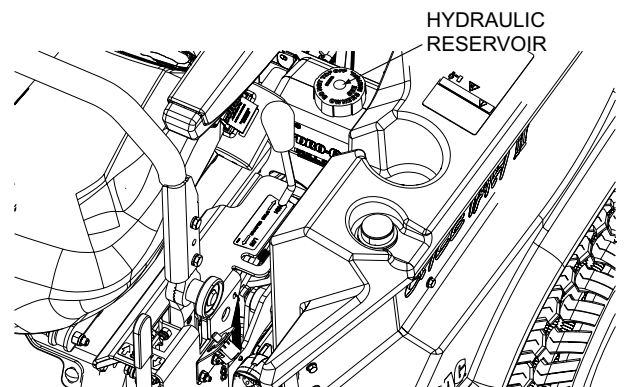

Figure 7-3. Hydraulic Oil Filter and Drain Plug

4. Re-install the drain plug, torque to 32 to 42 in/lbs and remove the hydraulic filter assembly from the RH hydraulic axle.
5. Place the container (capable of holding 6 quarts) under the LH hydraulic axle assembly. Remove the drain plug from the bottom of the LH hydraulic axle assembly. See Figure 7-3. Allow the fluid to drain into the container and properly discard it.

6. Re-install the drain plug and remove the hydraulic filter assembly from the LH hydraulic axle.
7. Install new hydraulic filters in the RH and LH hydraulic axles.
8. Remove the purge port plug next to the inlet fitting on both axles. See Figure 7-4.

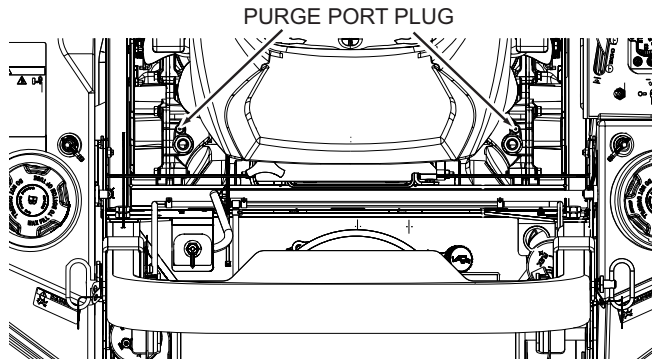

Figure 7-4. Axle Purge Port Plugs

9. Fill **both** hydraulic reservoirs with 20w50 oil (Scag p/n 486255 - 1 Quart or p/n 486254 - 1 Gallon) until the oil just appears at each axle purge port. Approximately 10 quart capacity. Reinstall the purge port plugs and torque to 32 to 42 in/lbs.

-NOTE-

Each axle will fill with oil using approximately 5 quarts of oil. Reinstall the purge port plugs and fill the hydraulic expansion reservoir to the proper level as explained in Section 7.3.

10. Replace the reservoir fill cap and cover.
11. Start the engine and operate the steering control levers forward and backward for two minutes to purge the air out of the hydraulic system. Check the oil level in the reservoir. If necessary, add oil to the reservoir.

7.4 ENGINE OIL

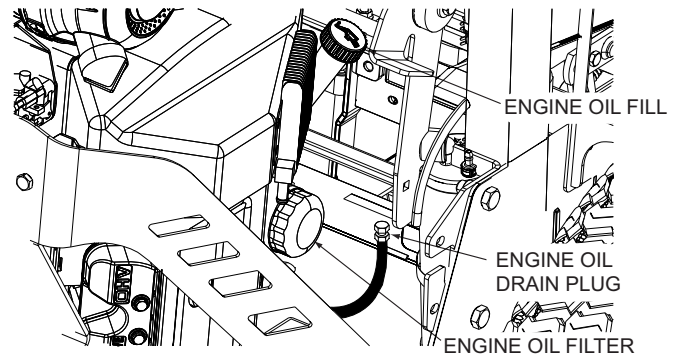

Figure 7-5. Engine Oil Fill/Dipstick, Filter and Drain Locations

A. CHECKING ENGINE CRANKCASE OIL LEVEL

The engine oil level should be checked after every 8 hours of operation or daily as instructed in the Engine Operator's Manual furnished with this mower.

B. CHANGING ENGINE CRANKCASE OIL

After the first 20 hours of operation, change the engine crankcase oil and replace the oil filter. Thereafter, change the engine crankcase oil after every 100 hours of operation or bi-weekly, whichever occurs first. Refer to the Engine Operator's Manual furnished with this mower for instructions.

C. CHANGING ENGINE OIL FILTER

After the first 20 hours of operation, replace the engine oil filter. Thereafter, replace the oil filter after every 200 hours of operation or every month, whichever occurs first. Refer to Engine Operator's Manual for instructions. See Figure 7-4.

Section 7

7.5 ENGINE FUEL SYSTEM

DANGER

To avoid injury from burns, allow the mower to cool before removing the fuel tank cap and refueling.

A. FILLING THE FUEL TANKS

Fill to the bottom of the filler neck insert (approximately 8 gallons per fuel tank indicating Full (F) on the fuel gauge) at the beginning of each operating day. See Figure 7-6. Do not overfill. Use clean, fresh unleaded gasoline with a minimum octane rating of 87 and a maximum of 10% Ethanol.

DO NOT use E85 Fuel. Using E85 Fuel will cause severe damage to the engine.

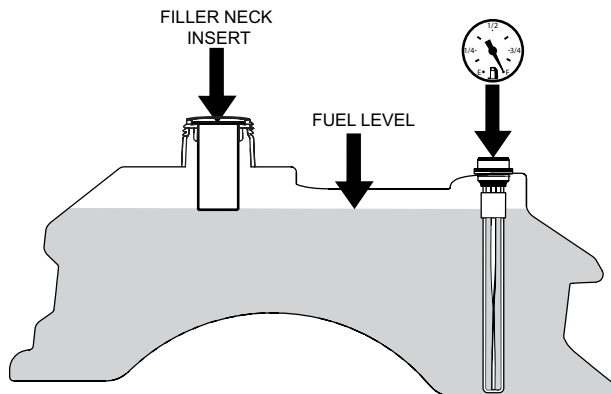

Figure 7-6. C.A.R.B. / EPA Phase 3 Fuel Level

To avoid personal injury or property damage, use extreme care in handling gasoline. Gasoline is extremely flammable and the vapors are explosive.

1. Extinguish all cigarettes, cigars, pipes and other sources of ignition.
2. Use only an approved gasoline container.
3. Never remove the gas cap or add fuel with the engine running. Allow the engine to completely cool before fueling.
4. Never fuel the machine indoors or in an enclosed trailer.
5. Never store the machine or fuel container where there is an open flame, spark or pilot light such as on a water heater or other appliances.

6. Never fill containers inside a vehicle or on a truck or trailer bed with a plastic liner. Always place containers on the ground away from your vehicle before filling.
7. Remove the machine from the truck or trailer and fuel on the ground. If this is not possible, then refuel the machine with a portable container, rather than from a gasoline dispenser nozzle.
8. Keep the nozzle in contact with the rim of fuel tank or container opening at all times until fueling is complete. Do not use a nozzle lock-open device.
9. If fuel is spilled on clothing, change clothing immediately and wash affected skin.
10. DO NOT start the engine until any spilled fuel has been cleaned up or has evaporated.
11. Replace gas cap and tighten securely. Tighten the fuel cap until it ratchets.

B. REPLACING IN-LINE FUEL FILTER ELEMENTS

The engine fuel filter should be replaced after every 500 hours of operation or annually, whichever occurs first. See Figure 7-7.

1. Close the shut-off valve.
2. Remove and replace the engine fuel filter. Open the fuel shut-off valve.

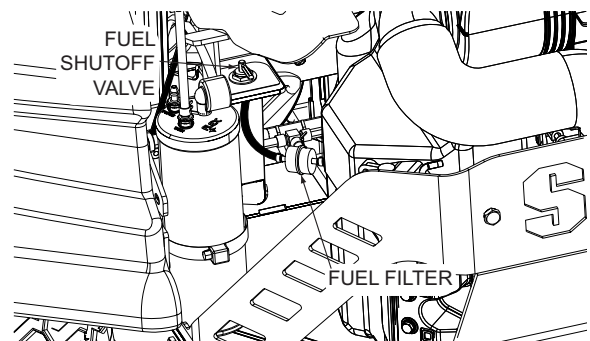

Figure 7-7. Fuel Filter

7.6 ENGINE AIR CLEANER

A. CLEANING AND/OR REPLACING AIR CLEANER ELEMENT

For any air cleaner, the operating environment dictates the air cleaner service periods. Inspect and clean the air cleaner element after every 100 hours of operation or bi-weekly, whichever occurs first and replace the element if required.

- NOTE -

In extremely dusty conditions it may be necessary to check the element once or twice daily to prevent engine damage.

1. Release the two latches securing the air cleaner cover to the air cleaner assembly and remove the cover. Set aside.
2. Remove the air cleaner and inspect.
3. Clean or replace the air cleaner and foam pre-cleaner as recommended by the engine manufacturer.
4. Replace the air cleaner cover and be sure to snap the two latches closed.

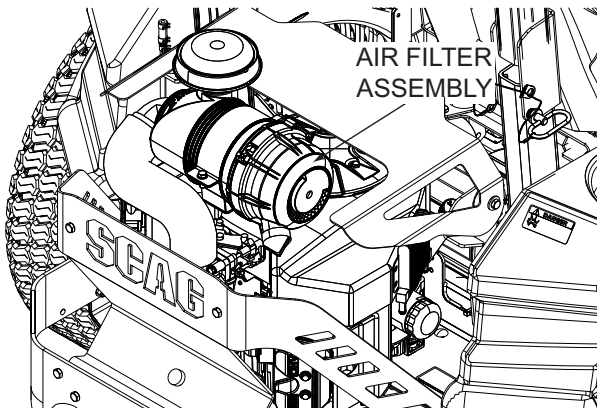

Figure 7-8. Air Filter Assembly

7.7 BATTERY

! WARNING

Lead-acid batteries produce flammable and explosive gases. To avoid personal injury when checking, testing or charging batteries, **DO NOT** use smoking materials near batteries. Keep arcs, sparks and flames away from batteries. Provide proper ventilation and wear safety glasses.

! WARNING

Battery posts, terminals, and related accessories contain lead and lead compounds, chemicals known to cause cancer and reproductive harm. **Wash hands after handling.**

! WARNING

Electric storage battery fluid contains sulfuric acid which is **POISON** and can cause **SEVERE CHEMICAL BURNS**. Avoid contact of fluid with eyes, skin, or clothing. Use proper protective gear when handling batteries. **DO NOT** tip any battery beyond 45° angle in any direction. If fluid contact does occur, follow first aid suggestions below.

BATTERY ELECTROLYTE FIRST AID

External Contact — Flush with water.

Eyes — Flush with water for at least 15 minutes and get medical attention immediately.

Internal — Drink large quantities of water. Follow with Milk Of Magnesia, beaten egg, or vegetable oil. Get medical attention immediately. In case of internal contact, DO NOT give fluids that would induce vomiting.

Section 7

A. CHARGING THE BATTERY

Refer to the battery charger's manual for specific instructions.

Under normal conditions the engine's alternator will have no problem keeping a charge on the battery. If the battery has been completely discharged for a long period of time, the alternator may not be able to recharge the battery, and a battery charger will be required.

DO NOT charge a frozen battery. It may explode and cause injury. Let the battery warm before attaching a charger.

Whenever possible, remove the battery from the mower before charging and make sure the electrolyte covers the plates in all cells.

 <h2 style="margin: 0;">WARNING</h2>
<p>BATTERIES PRODUCE EXPLOSIVE GASES. Charge the battery in a well ventilated space so gases produced while charging can dissipate.</p>

Charging rates between 3 and 50 amperes are satisfactory if excessive gassing or spewing of electrolyte does not occur or the battery does not feel excessively hot (over 125°F). If spewing or gassing occurs or the temperature exceeds 125°F, the charging rate must be reduced or temporarily stopped to permit cooling.

B. JUMP STARTING

1. The booster battery must be a 12 volt type. If a vehicle is used for jump starting, it must have a negative ground system.
2. When connecting the jumper cables, connect the positive cable to the positive battery post, then connect the negative cable to the negative battery post.

7.8 DRIVE BELTS

All drive belts are spring-loaded and self-tensioning, however after the first 2, 4, 8 and 10 hours of operation, the belts should be checked for proper alignment and wear. Thereafter, check the belts after every 40 hours of operation or weekly, whichever occurs first.

- NOTE -

If you experience frequent belt wear or breakage, see your authorized Scag service center for belt adjustment.

 <h2 style="margin: 0;">WARNING</h2>
<p>If the pump drive belt fails, steering control will be lost which could result in serious injury or death. Replace the pump drive belt as needed or every 400 hours / 2 years, whichever occurs first.</p>

7.9 CUTTER BLADES

A. BLADE INSPECTION

1. Remove the ignition key before servicing the blades.
2. Raise the mower deck to the highest position. Place the lanyard pin in the highest cutting height position to prevent the cutter deck from falling.

 <h2 style="margin: 0;">WARNING</h2>
<p>Always wear proper hand and eye protection when working with cutter blades.</p>

3. Check the cutter blades for straightness. If the cutter blades appear bent, they will need to be replaced.
4. Check the cutter blades for wear. If any part of the cutter blade is worn to 1/2 its original thickness, replace the cutter blade.

 <h2 style="margin: 0;">WARNING</h2>
<p>Do not attempt to straighten a bent blade, and never weld a broken or cracked blade. Always replace it with a new blade to assure safety.</p>

5. Check the cutter blades for gouges. If there are gouges on the top or bottom surfaces of the cutter blade, replace the cutter blade.
6. If a blade cutting edge is dull or nicked, it should be sharpened. Remove the blades for sharpening. See "Blade Replacement".

- NOTE -

Keep the blades sharp. Cutting with dull blades not only yields a poor mowing job, but slows the cutting speed of the mower and causes extra wear on the engine and the blade drive by pulling hard.

B. BLADE SHARPENING

- NOTE -

If possible, use a file to sharpen the blade. Using a wheel grinder may burn the blade.

- NOTE -

DO NOT sharpen the blades beyond 1/3 of the width of the blade. See Figure 7-9.

1. Sharpen the cutting edge at the same bevel as the original. See Figure 7-9. Sharpen only the top of the cutting edge to maintain sharpness.

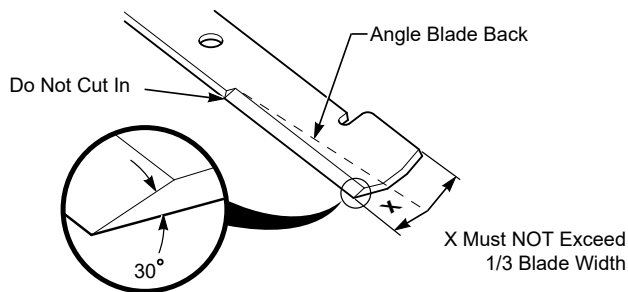

Figure 7-9. Blade Sharpening

2. Check the balance of the blade. If the blades are out of balance, vibration and premature wear can occur. The cutter blades should be balanced to 1-1/2 oz-in. See your authorized Scag dealer for blade balancing or special tools, if you choose to balance your own blades.

C. BLADE REPLACEMENT

! WARNING

Always wear proper hand and eye protection when working with cutter blades.

1. Remove the ignition key before replacing the blades.
2. Raise the mower deck to the highest position. Place the lanyard pin in the highest cutting height position to prevent the cutter deck from falling.
3. Secure the cutter blades to prevent them from rotating, (use the optional Blade Buddy tool P/N 9212, to assist in securing the cutter blades), remove the nut from the blade attaching bolt. Remove the cutter blade, bolt and spacer from the spindle shaft. See Figure 7-10.

- NOTE -

The front of the machine will have to be raised slightly to remove the blade bolt from the cutter spindle.

! CAUTION

Inspect the cutter blade spacer(s) and washer for wear and/or cupping. Replace the worn parts. Worn spacer(s) and/or washer will not allow proper tightening of the cutter blade and can lead to cutter blade failure, personal injury or property damage.

4. To install the new cutter blade, put the flat washer onto the blade bolt and slide the bolt into the hole in the cutter blade.

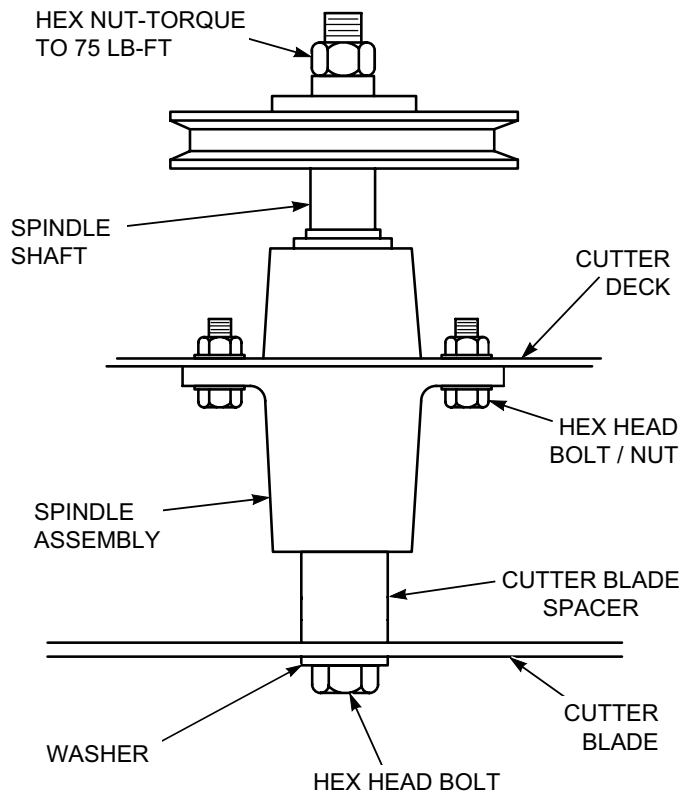

Figure 7-10. Blade Replacement

- NOTE -

Be sure that the blade is installed with the lift wing toward the top.

5. Install the spacer onto the blade bolt and insert the bolt into the cutter spindle shaft.
6. Install the hex nut to the blade bolt at the top of the cutter spindle. Secure the blades from rotating and torque to 75 lb-ft. See Figure 7-10.

7.10 TIRES

Check the tire pressures after every 8 hours of operation or daily.

Caster Wheels	Flat Free
Drive Wheels	12 PSI

7.11 BODY, DECK, AND UPHOLSTERY

CAUTION

Do not wash any portion of the equipment while it is hot. Do not wash the engine; use compressed air.

1. After each use, wash the mower and cutter deck. Use cold water and automotive cleaners. Do not use pressure cleaners.
2. Do not spray electrical components.
3. Use a mild soap solution or a vinyl/rubber cleaner to clean the seat.
4. Repair damaged metal surfaces using Scag touch-up paint available from your authorized Scag dealer. Wax the mower for maximum paint protection.

ILLUSTRATED PARTS LIST

8.1 SCAG APPROVED ATTACHMENTS AND ACCESSORIES

Attachments and accessories manufactured by companies other than Scag Power Equipment are not approved for use on this machine.

Scag approved attachments and accessories:

<u>Accessories</u>	<u>P/N</u>
<u>Grass Collection Systems</u>	
GC-3B Three-Bag catcher	901S
GC-CS "Clam Shell" catcher	901T
Install Kit for SCZ-61V	901X
<u>Mulching Accessories</u>	
Mulch Plate (61)	9288
Mulch Plate (72)	920F
Hurricane Plus Mulch System (61)	9285
Hurricane Plus Mulch System (72)	920E
<u>Miscellaneous</u>	
Blade Buddy	9212
Trailer Hitch	9242
Tiger Stripe Kit (61/72)	923G
-Install Kit (61/72)	921W
Chrome Wheel Cover (12")	920J
Tiger Eye Air Filter Monitor	922U
OCDG, Electric (61 Velocity Plus)	925D
OCDG, Electric (72 Velocity Plus)	925J

<u>Accessories</u>	<u>P/N</u>
<u>Scag Premium Lubricants</u>	
Chassis Grease	486257
Spindle Grease	486258
Hydraulic System Oil (1 gal)	486254
Hydraulic System Oil (1 qt)	486255

NOTES

61V & 72V CUTTER DECKS

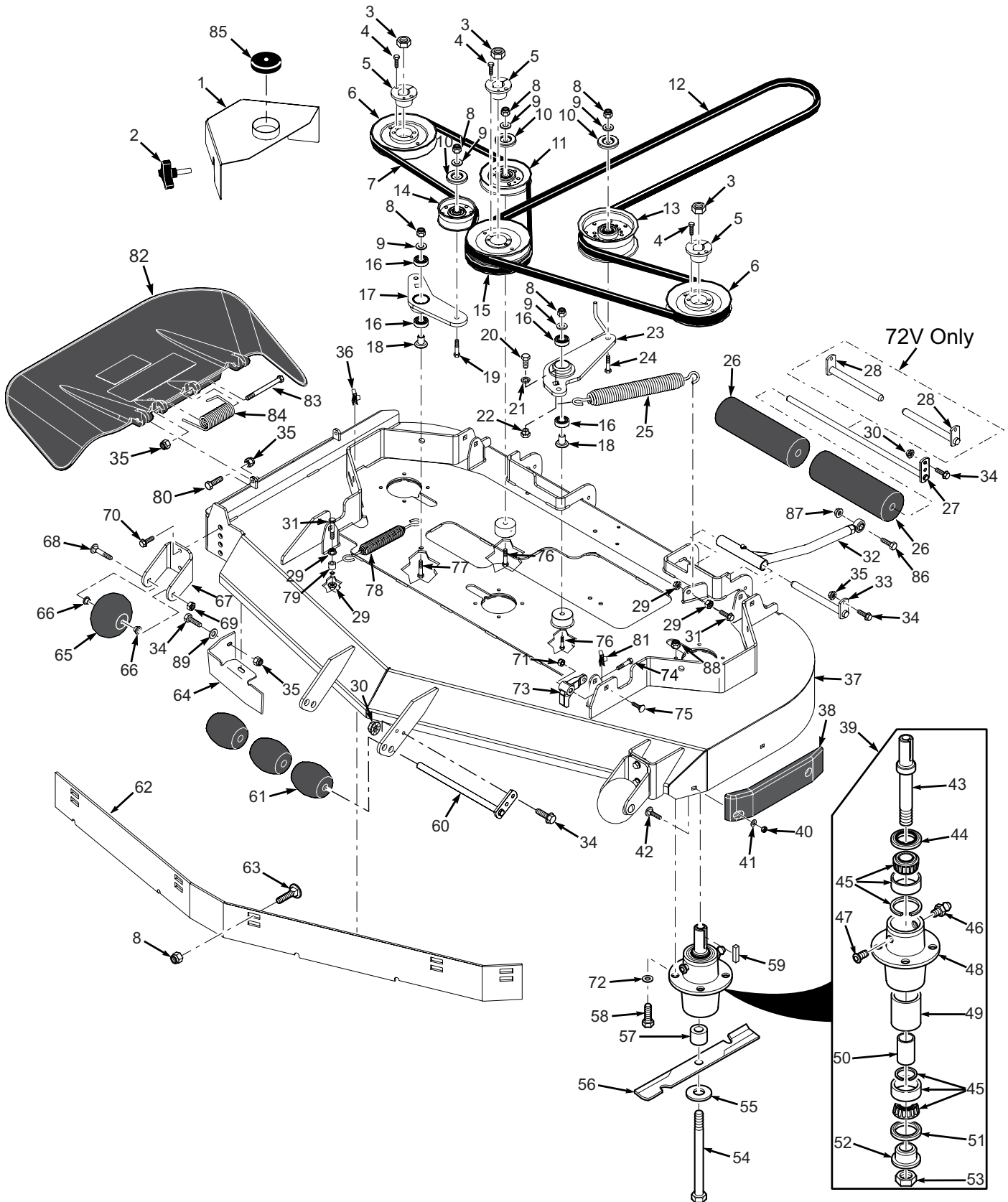

61V & 72V CUTTER DECKS

Ref. No.	Part No.	Description	61	72
1	463194	Belt Cover, LH (INCL 85)	x	
	463195	Belt Cover, RH (INCL 85)	x	
	462409	Belt Cover, 72V		x
2	481625-01	Knob w/Stud	x	x
3	04020-09	Nut, 5/8-11 UNC	x	x
4	04001-172	Bolt, Hex Head 1/4-20 x 1"	x	x
5	48926	Tapered Hub, 1.125" Bore	x	x
6	483286	Pulley, 6.32" Dia.	x	
	484050	Pulley, 7.50" Dia.		x
7	483157	Belt	x	
	484159	Belt		x
8	04021-09	Nut, Elastic Stop 3/8-16	x	x
9	04043-04	Flat washer, 3/8-.391 x .938 x .105	x	x
10	424367	Dust Shield	x	x
11	48181	Pulley, Idler	x	x
12	483741	Belt, Deck Drive	x	
	484088	Belt, Deck Drive		x
13	483210	Pulley, 5" Idler	x	x
14	486045	Pulley, 3-1/2" Idler	x	x
15	483287	Pulley, 6.32" Dia. Double Groove	x	
	484051	Pulley, 7.50" Dia. Double Groove		x
16	48224	Bearing	x	x
17	461946	Idler Arm Assy. (incl. #16)	x	x
18	43689	Pivot, Idler	x	x
19	04001-31	Bolt, Hex Head 3/8-16 x 2-1/2"	x	x
20	04001-27	Bolt, Hex Head 7/16-14 x 1"	x	x
21	04030-05	Lock washer, 7/16" Spring	x	x
22	43686	Boss, Spring Anchor	x	x
23	462269	Idler Arm Assy. (incl. #16)	x	x
24	04001-54	Bolt, Hex Head 3/8-16 x 3"	x	x
25	483246	Spring, LH Cutter Deck	x	x
26	48038	Guide Roller	x	x
27	451118	Shaft Weldment	x	
28	45944	Shaft Weldment		x
29	04019-04	Nut, Serrated Flange 3/8-16	x	x
30	04117-01	Nut, Lock Elastic Stop, 5/16-18	x	x
31	04001-136	Bolt, Hex Head 3/8-16 x 1-1/2" Grade 8	x	x
32	462225	Pusharm Assy., LH	x	x
	462226	Pusharm Assy., RH	x	x
33	451240	Rod Weldment, Pusharm	x	x
34	04001-09	Bolt, Hex Head 5/16-18 x 1"	x	x
35	04021-10	Nut, Elastic Stop 5/16-18	x	x
36	04110-04	U-Nut, 3/8-16	x	x
37	463243	Cutter Deck w/Decals	x	
	463244	Cutter Deck w/Decals		x
38	483176	Wear Pad	x	
	483174	Wear Pad		x
39	461663	Spindle Assembly	x	x
40	04021-04	Nut, Center Lock 5/16-18	x	x
41	04040-04	Flat washer, 5/16-.344 x .688 x .065	x	x
42	04003-12	Bolt, Carriage 5/16-18 x 3/4"	x	x
43	43589	Shaft, Spindle	x	x
44	481024	Seal, Top	x	x
45	481022	Bearing Assembly	x	x

Ref. No.	Part No.	Description	61	72
46	48114-04	Grease Fitting	x	x
47	48677	Relief Fitting, Spindle	x	x
48	43644	Spindle Housing	x	x
49	43312	Spacer, Outside	x	x
50	43296	Spacer, Inside	x	x
51	481025	Seal, Bottom	x	x
52	43297	Spindle Bushing	x	x
53	481035	Nut, Special 1-1/16 - 18	x	x
54	04001-41	Bolt, Hex Head 5/8-11 x 9-1/2"	x	x
55	04043-06	Flat washer, 5/8-.688 x 1.75 x .134 HD	x	x
56	482881	Cutter Blade, 21"	x	
	482882	Cutter Blade, 24-1/2"		x
57	43590	Spacer, Spindle Bottom	x	x
58	04001-176	Bolt, Hex Head 5/16-18 x 1-3/4" Grade 8	x	x
59	04063-08	Key, 1/4 x 1/4 x 2"	x	x
60	45944	Shaft Weldment	x	x
61	482295	Wheel, Anti-Scalp	x	x
62	424841	Baffle, Flange - 61V	x	
	424917	Baffle, Flange - 72V		x
63	04003-23	Bolt, Carriage 3/8-16 x 1"	x	x
64	424209	Baffle, Turbo - 61V	x	
	*425625	Discharge Baffle 61V	x	
	424856	Baffle, Turbo - 72V		x
	*423958	Discharge Baffle 72V		x
65	481632	Wheel, Anti-Scalp	x	x
66	48100-15	Bushing, .376 ID Oilite	x	x
67	422478	Bracket, Anti-Scalp Wheel	x	x
68	04003-26	Bolt, Carriage 3/8-16 x 4"	x	x
69	04021-05	Nut, Center Lock 3/8-16	x	x
70	04017-27	Bolt, Hex Head 3/8-16 x 1" Serrated Flange	x	x
71	04021-11	Nut, Elastic Stop 7/16-14	x	x
72	04030-03	Lock Washer, 5/16	x	x
73	485528	Lever, Deck Level	x	x
74	04107-05	Bolt, 3/8-16 x 2-1/2" w/Patch	x	x
75	04003-42	Bolt, Carriage 7/16-14 x 2-1/4"	x	x
76	04001-54	Bolt, Hex Head 3/8-16 x 3"	x	x
77	04001-46	Bolt, Hex Head 3/8-16 x 2-1/4"	x	x
78	483703	Deck Spring	x	x
79	43063	Spacer	x	x
80	04001-12	Bolt, Hex Head 5/16-18 x 1-3/4"	x	x
81	04110-03	U-Nut, 3/8-16	x	x
82	461846	Discharge Chute Assy. 61V	x	
	*462477	CA Discharge Chute Assy.	x	
	462132	Discharge Chute Assy. 72V		x
	*462478	CA Discharge Chute Assy.		x
83	04001-154	Bolt, Hex Head 5/16-18 x 4-3/4"	x	x
84	483378	Spring, Discharge Chute	x	x
85	484368	Cap, Spindle	x	x
86	04001-128	Bolt, Hex Head 5/8-11 x 3/2"	x	x
87	04021-23	Nut, Centerlock, 5/8-11	x	x
88	04021-22	Nut, Lock Elastic Stop, 5/16-18	x	x
89	04040-15	Flat Washer, 5/16 - .375 x .875 x .083	x	x

* = California Models Only (not shown)

61RD & 72 RD CUTTER DECK

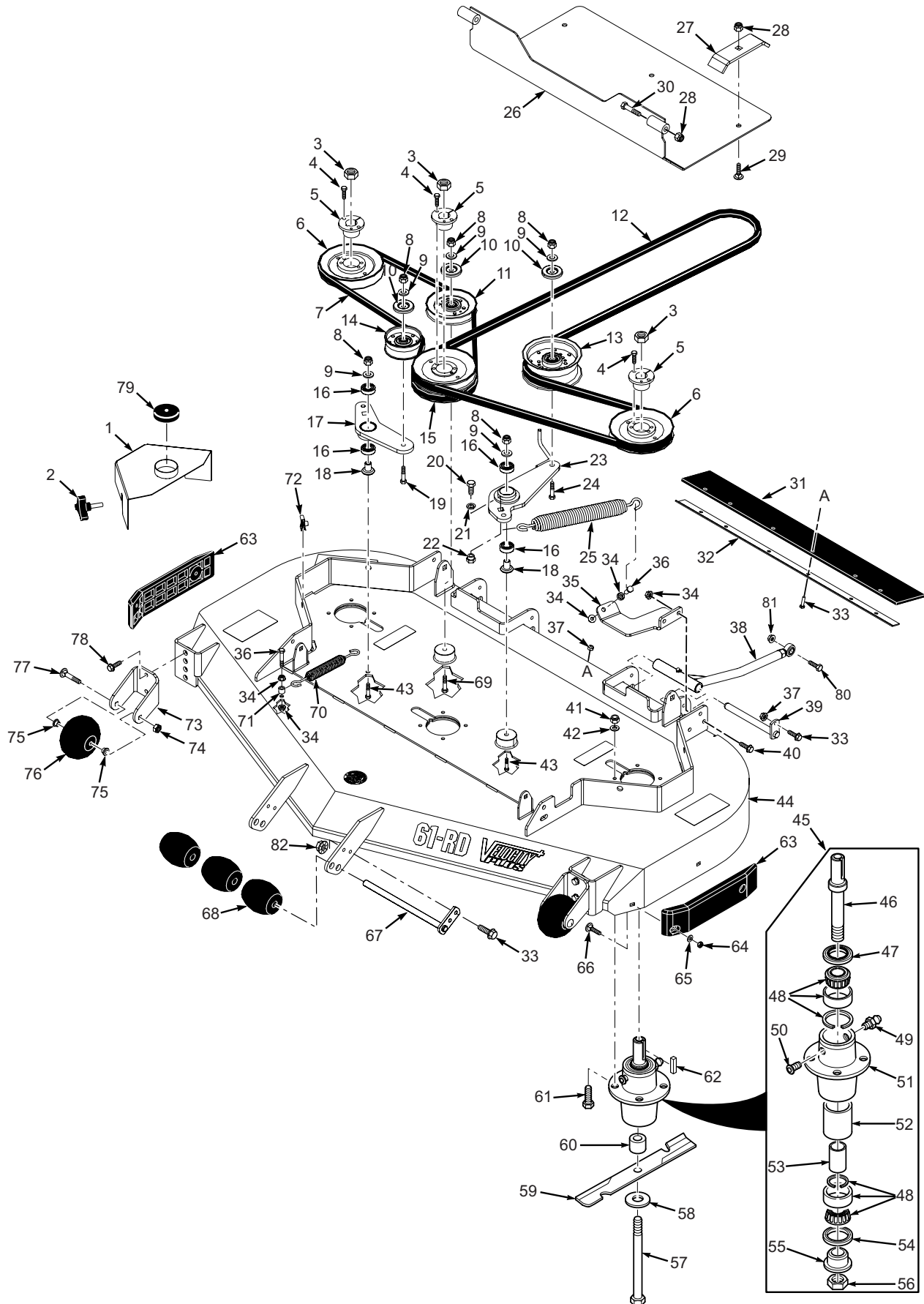

61RD & 72RD CUTTER DECK

Ref. No.	Part No.	Description
1	463194	Belt Cover, LH 61V
	463195	Belt Cover, RH 61V
	462409	Belt Cover, 72RD
2	481625-01	Knob w/Stud
3	04020-09	Nut, 5/8-11 UNC
4	04001-172	Bolt, Hex Head 1/4-20 x 1"
5	48926	Tapered Hub, 1.125" Bore
6	483286	Pulley, 6.32" Dia. 61RD
	484050	Pulley 7.5" Dia. 72RD
7	483157	Belt, 61RD RH Cutter Deck
	484159	Belt, 72RD RH Cutter Deck
8	04021-09	Nut, Elastic Stop 3/8-16
9	04043-04	Flat washer, 3/8-.391 x .938 x .105
10	424367	Dust Shield
11	48181	Pulley, Idler
12	483741	Belt, Deck Drive
13	483210	Pulley, 5" Idler
14	486045	Pulley, 3-1/2" Idler
15	483287	Pulley, 6.32" Dia. Double Groove 61RD
	484051	Pulley, 7.5" Dia. Double Groove 72RD
16	48224	Bearing
17	461946	Idler Arm Assy. (incl. #16)
18	43689	Pivot, Idler
19	04001-31	Bolt, Hex Head 3/8-16 x 2-1/2"
20	04001-27	Bolt, Hex Head 7/16-14 x 1"
21	04030-05	Lock washer, 7/16" Spring
22	43686	Boss, Spring Anchor
23	462269	Idler Arm Assy. Deck Drive (incl. #16)
24	04001-54	Bolt, Hex Head 3/8-16 x 3"
25	483246	Spring, LH Cutter Deck
26	452341	Weldment, Debris Shield
27	425897	Mounting Bracket, Shield
28	04021-10	Nut, Elastic Stop 5/16-18
29	04003-38	Bolt, Carriage 5/16-18 x 1-1/2"
30	04001-13	Bolt, Hex Head 5/16-18 x 2-3/4"
31	484557	Pad, Rubber
32	425899	Retaining Plate, Pad
33	04001-09	Bolt, Hex Head 5/16-18 x 1"
34	04019-04	Nut, Serrated Flange 3/8-16
35	425335	Spring Mount, SMCZ
36	04001-136	Bolt, Hex Head 3/8-16 x 1-1/2" Grade 8
37	04021-10	Nut, Elastic Stop 5/16-18
38	462225	Pusharm Assembly, LH
	462226	Pusharm Assembly, RH
39	451240	Rod Weldment, Pusharm
40	04001-19	Bolt, Hex Head 3/8-16 x 1"
41	04021-22	Nut, Elastic Stop 5/16-18 Grade 8
42	04030-03	Lock washer, 5/16"
43	04001-54	Bolt, Hex Head 3/8-16 x 3"
44	463245	Cutter Deck Assembly w/Decals SCZII-61RD
	463622	Cutter Deck Assembly w/Decals SCZII-72RD

Ref. No.	Part No.	Description
45	461663	Spindle Assembly
46	43589	Shaft, Spindle
47	481024	Seal, Top
48	481022	Bearing Assembly
49	48114-04	Grease Fitting
50	48677	Relief Fitting, Spindle
51	43644	Spindle Housing
52	43312	Spacer, Outside
53	43296	Spacer, Inside
54	481025	Seal, Bottom
55	43297	Spindle Bushing
56	481035	Nut, Special 1-1/16 - 18
57	04001-41	Bolt, Hex Head 5/8-11 x 9-1/2"
58	04043-06	Flat washer, 5/8-.688 x 1.75 x .134 HD
59	482881	Cutter Blade, 21" 61RD
	482882	Cutter Blade, 24.5" 72RD
60	43590	Spacer, Spindle Bottom
61	04001-176	Bolt, Hex Head 5/16-18 x 1-3/4" Grade 8
62	04063-08	Key, 1/4 x 1/4 x 2"
63	483176	Wear Pad 61RD
	483174	Wear Pad 72RD
64	04021-04	Nut, Center Lock 5/16-18
65	04040-04	Flat washer, 5/16-.344 x .688 x .065
66	04003-12	Bolt, Carriage 5/16-18 x 3/4"
67	45944	Shaft Weldment
68	482295	Wheel, Anti-Scalp
69	04001-46	Bolt, Hex Head 3/8-16 x 2-1/4"
70	483703	Deck Spring
71	43063	Spacer
72	04110-04	U-Nut, 3/8-16
73	422478	Bracket, Anti-Scalp Wheel
74	04021-05	Nut, Center Lock 3/8-16
75	48100-15	Bushing, .376 I.D. Oilite
76	481632	Wheel, Anti-Scalp
77	04003-26	Bolt, Carriage 3/8-16 x 4"
78	04017-27	Bolt, Hex Head Serrated Flange 3/8-16 x 1"
79	484368	Cap, Spindle
80	04001-128	Bolt, Hex Head, 5/8-11 x 3 1/2"
81	04021-23	Nut, Centerlock, 5/8-11
82	04117-01	Nut, Lock Elastic Stop, 5/16-18

CUTTER DECK CONTROLS

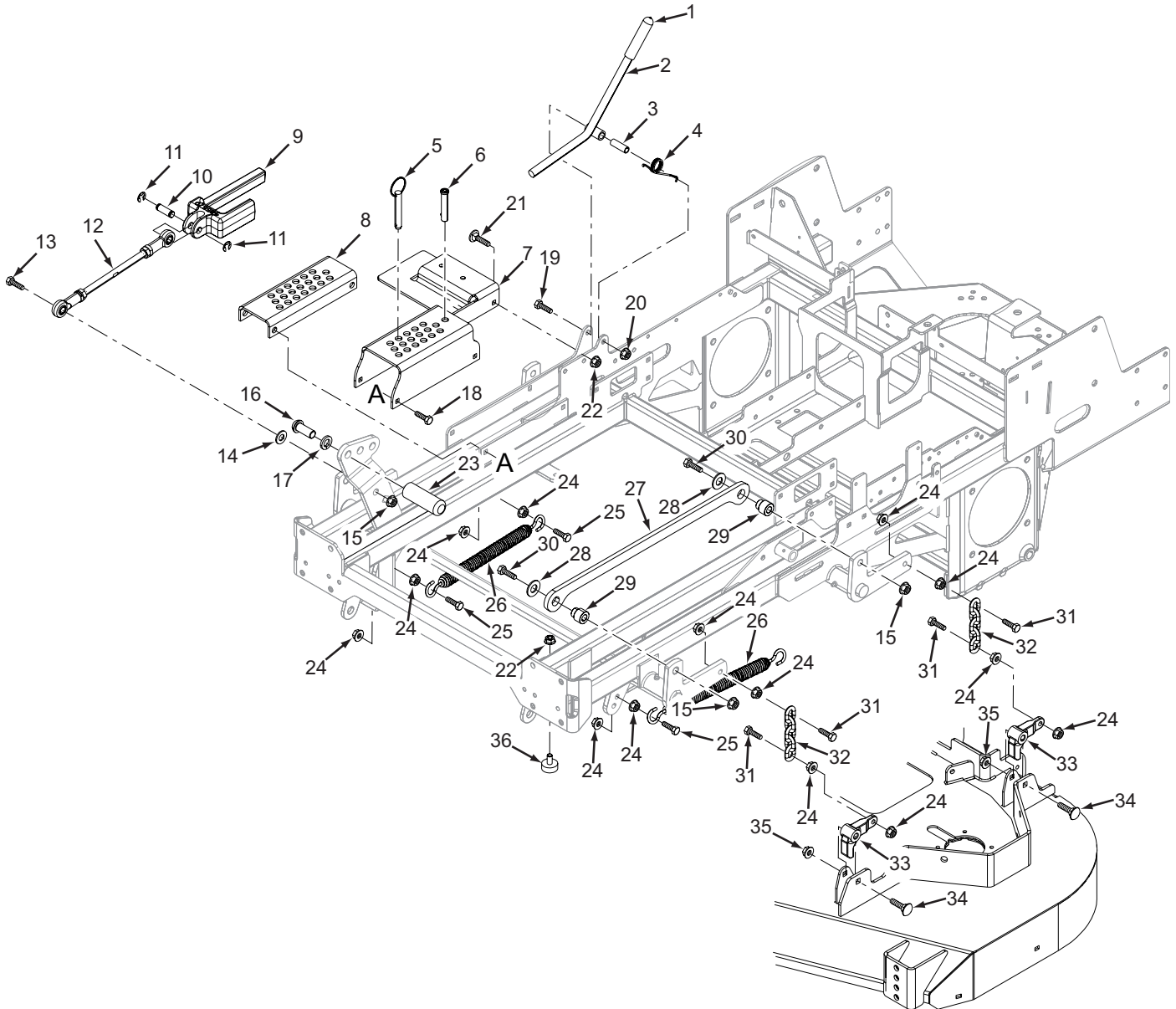

CUTTER DECK CONTROLS

Ref. No.	Part No.	Description
1	481477	Grip, Deck Latch
2	462253	Deck Latch Assembly w/Grip
3	43668	Spacer, Deck Latch
4	484191	Spring, Torsion Return Lever
5	483345	Ring Pin Assembly w/Lanyard
6	04059-01	Pin, Locking
7	463235-G	Adjustment Bracket, Upper Cut Height (Scag Gold)
	463235-B	Adjustment Bracket, Upper Cut Height (Black)
8	452408	Adjustment Bracket, Lower Cut Height
9	462883	Slide, Height Adjustment Assembly (INCL. 10,11,12)
10	43487	Pin, Deck Lift
11	04050-18	Retaining Ring, 1/2" External "E"
12	484141	Linkage, Deck Lift
	481765	Rod End, 1/2-20 RH Female
	481766	Rod End, 1/2-20 LH Female
	04020-27	Nut, 1/2-20 UNF Jam
	04020-28	Nut, 1/2-20 UNF LH Jam
13	04001-72	Bolt, Hex Head 1/2-13 x 2"
14	04040-07	Flat washer, 1/2-.531 X 1.062 X .095
15	04021-07	Nut, Lock Elastic Stop, 1/2-13
16	04108-04	Bolt, 5/8-11 x 1-1/2"
17	04030-07	Lock Washer, 5/8 Spring
18	04006-02	Bolt, 5/16-18 x 1-1/4"
19	04001-22	Bolt, 3/8-16 x 2-3/4"
20	04021-09	Nut, Lock Elastic Stop, 3/8-16
21	04003-12	Bolt, Carriage, 5/16-18 x 3/4"
22	04019-03	Nut, Serrated Flange, 5/16-18
23	424504	Pedal, Foot
24	04019-04	Nut, Serrated Flange, 3/8-16
25	04001-136	Bolt, 3/8-16 x 1-1/2"
26	481598	Spring, Deck Lift
27	428214	Link, Deck Lift
28	04040-13	Flat Washer, 1/2- .562 x 1.375 x .109
29	431018	Pivot, Deck Link
30	04001-153	Bolt, 1/2-13 x 2-1/4"
31	04001-20	Bolt, 3/8-16 x 1-1/2"
32	482628	Chain Assembly (INCL. 24,31)
33	485528	Lever, Deck Level
34	04003-42	Bolt, Carriage 7/16-14 x 2-1/4"
35	04021-11	Nut, Elastic Stop, 7/16-14
36	481284	Bumper, Rubber

SHEET METAL COMPONENTS

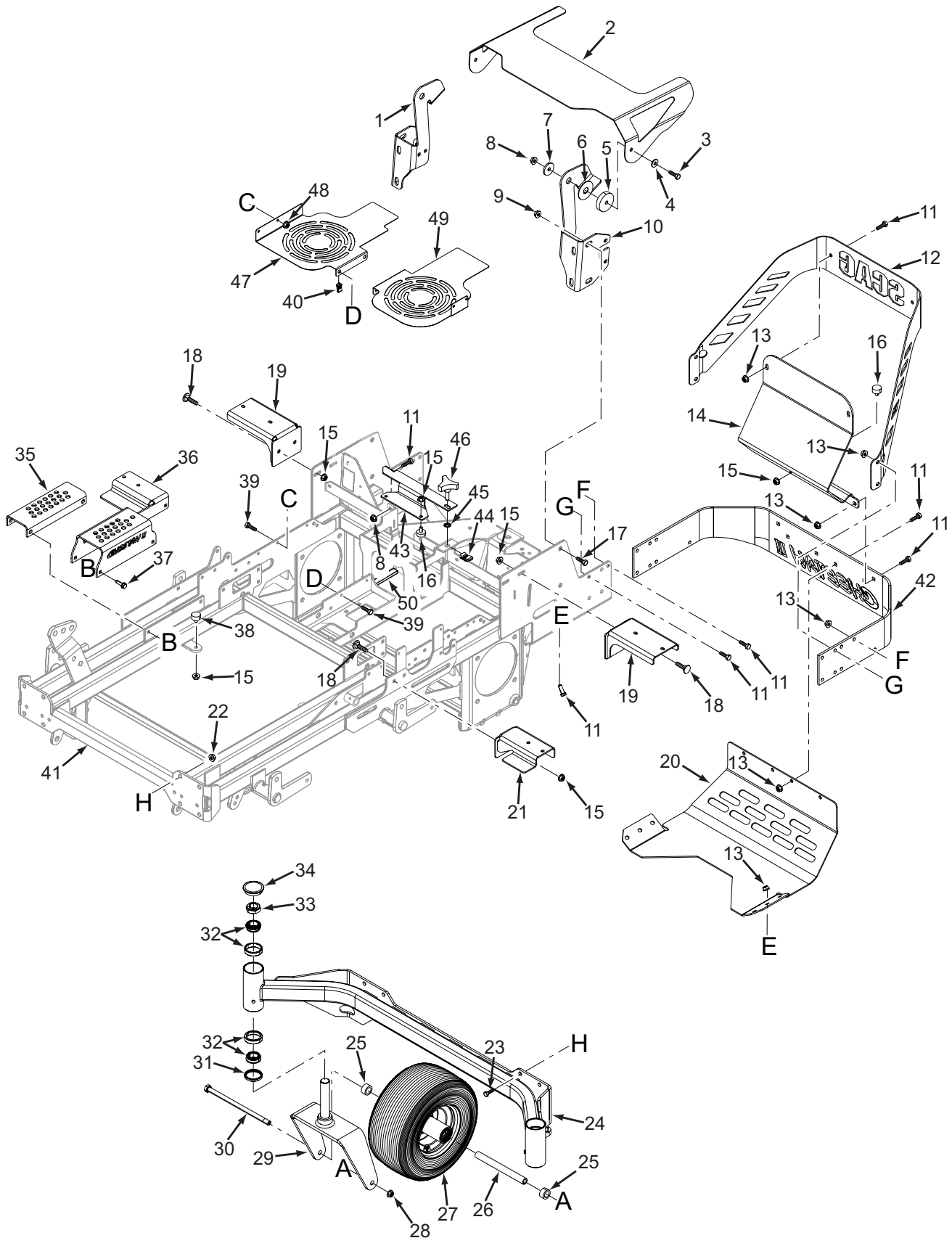

SHEET METAL COMPONENTS

Ref. No.	Part No.	Description
1	427178	Rops Mounting RH
2	428312	Hood, SCZII
3	04001-21	Bolt, 3/8-16 x 1-3/4"
4	04041-07	Flat Washer, 3/8 - .391 x .938 x .105
5	43740	Spacer, Hood
6	483471	Disc, Anti Friction
7	04041-11	Flat Washer, 3/8 - .406 x 1.5 x 7 Ga
8	04021-09	Nut, Lock Elastic Stop, 3/8-16
9	04117-04	Nut, Lock Flange Elastic Stop, 1/2-13
10	427177	Rops Mounting LH
11	04001-19	Bolt, 3/8-16 x 1"
12	428202-G	Engine Cover, Sides (Scag Gold)
	428202-B	Engine Cover, Sides (Black)
13	04019-04	Nut, Serrated Flange, 3/8-16
14	428333-G	Engine Cover, Rear (Scag Gold)
	428333-B	Engine Cover, Rear (Black)
15	04019-03	Nut, Serrated Flange, 5/16-18
16	481284	Bumper, Rubber
17	04001-70	Bolt, 1/2-13 x 1-1/4"
18	04003-12	Bolt, Carriage, 5/16-18 x 3/4"
19	428261	Mounting Bracket, Fuel Tank Rear
20	428292-G	Skid Plate, Rear (Scag Gold)
	428292-B	Skid Plate, Rear (Black)
21	428233	Mounting Bracket, Fuel Tank Front
22	04117-05	Nut, Lock Flange Elastic Stop, 7/16-14
23	04001-28	Bolt, 7/16-14 x 1-1/4"
24	452193-G	Caster Support 61V (Scag Gold)
	452193-B	Caster Support 61V (Black)
	452194-G	Caster Support 72V (Scag Gold)
	452194-B	Caster Support 72V (Black)
25	43584	Spacer, Caster Wheel
26	43583	Sleeve, Caster Wheel
27	9278	Caster Wheel Assembly (Scag Gold)
	924C	Caster Wheel Assembly (Black)
	482621	Bearing
	482622	Seal
28	04021-07	Nut, Lock Elastic Stop, 1/2-13
29	453110	Yoke Weldment
30	04001-167	Bolt, 1/2-13 x 9-1/2"
31	481025	Seal, 2" OD x 1.625 Bore
32	48668	Bearing 1" DIA
33	04021-20	Nut, Lock Jam Elastic Stop, 1"-14
34	484195	Grease Cap
35	452408	Bracket, Lower Cutting Height
36	428228	Bracket, Upper Cutting Height
37	04006-02	Bolt, 5/16-18 x 1-1/4"
38	484201	Bumper, Rubber
39	04017-05	Bolt, Serrated Flange, 1/4-20 x 3/4"
40	04110-01	U-Nut, 1/4-20
41	463242-G	Frame w/ Decals (Scag Gold)
	463242-B	Frame w/ Decals (Black)
42	428206-G	Bumper, Rear (Scag Gold)
	428206-B	Bumper, Rear (Black)
43	428236-G	Cover, Battery Box (Scag Gold)
	428236-B	Cover, Battery Box (Black)
44	04110-03	U-Nut, 3/8-16
45	04024-02	Nut, Push-On - 3/8 Thd
46	481625-01	Knob w/ Stud, 3/8-16 x 1-1/4"
47	425300-G	Fan Cover, RH (Scag Gold)
	425300-B	Fan Cover, RH (Black)
48	04019-02	Nut, Serrated Flange, 1/4-20
49	425299-G	Fan Cover, LH (Scag Gold)
	425299-B	Fan Cover, LH (Black)
50	48661	Pad, Rubber

SCZII ROLL-OVER PROTECTION STRUCTURE

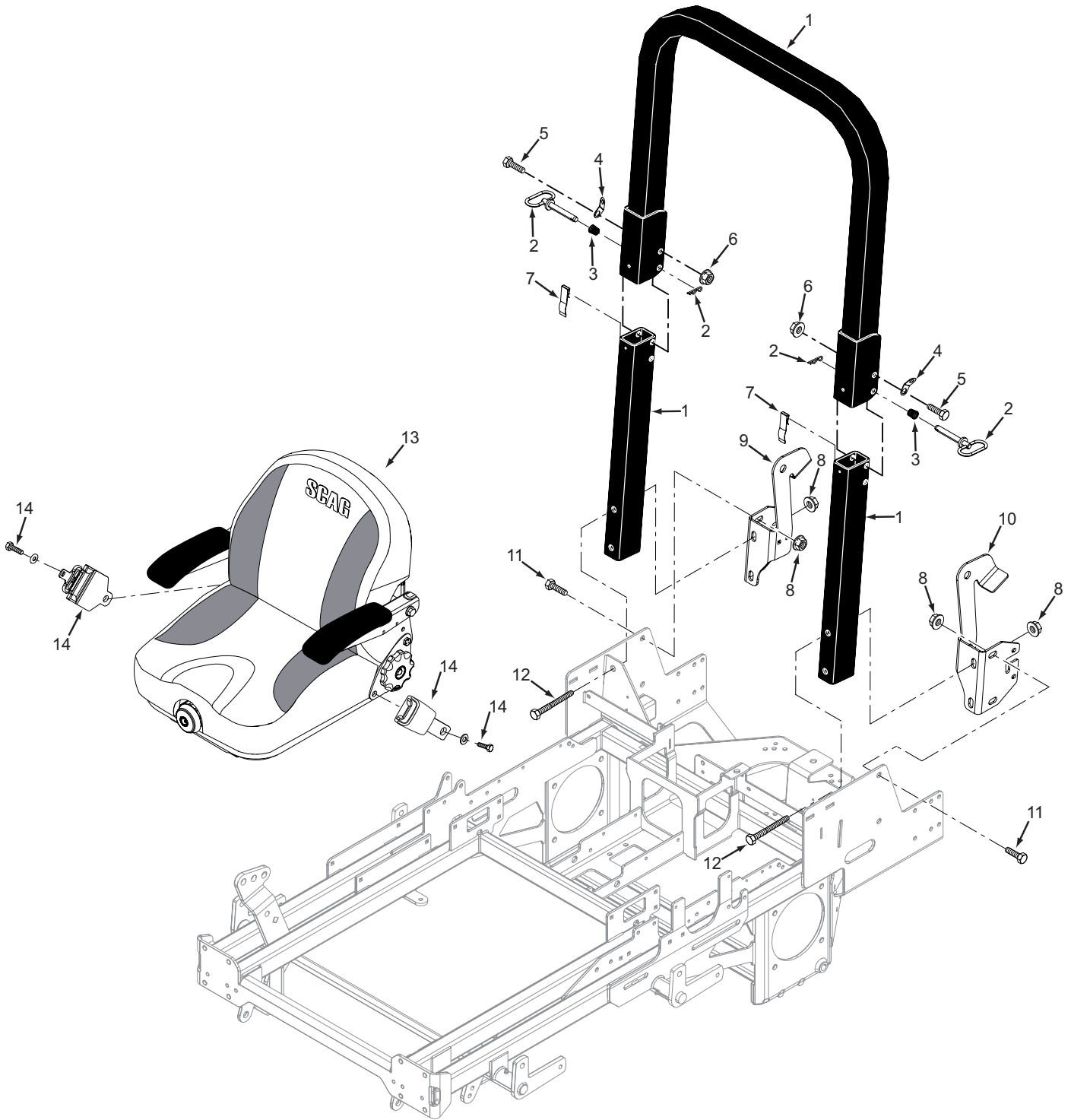

SCZII ROLL-OVER PROTECTION STRUCTURE

Ref. No.	Part No.	Description
1	463430	ROPS, Foldable SCZII
2	484168	Pin Assembly (incl. #3, #4)
3	484170	Spring, ROPS
4	484169	Clip, ROPS
5	04001-90	Bolt, Hex Head 1/2-13 x 3-1/4"
6	04021-07	Nut, Elastic Stop 1/2-13
7	484167	Spring Clip, ROPS
8	04117-04	Nut, Lock Flange Elastic Stop, 1/2-13
9	427178	Rops Mount RH
10	427177	Rops Mount LH
11	04001-70	Bolt, Hex Head 1/2-13 x 1-1/4"
12	04001-194	Bolt, Hex Head 1/2-13 x 4-1/4"
13	486591	Seat Assembly, Suspension (INCL 14)
	487076	Seat Assembly (INCL 14)
14	484717	Seat Belt Kit, Retractable, Suspension
	487274	Seat Belt Kit, Retractable

SCZII SEAT ASSEMBLY

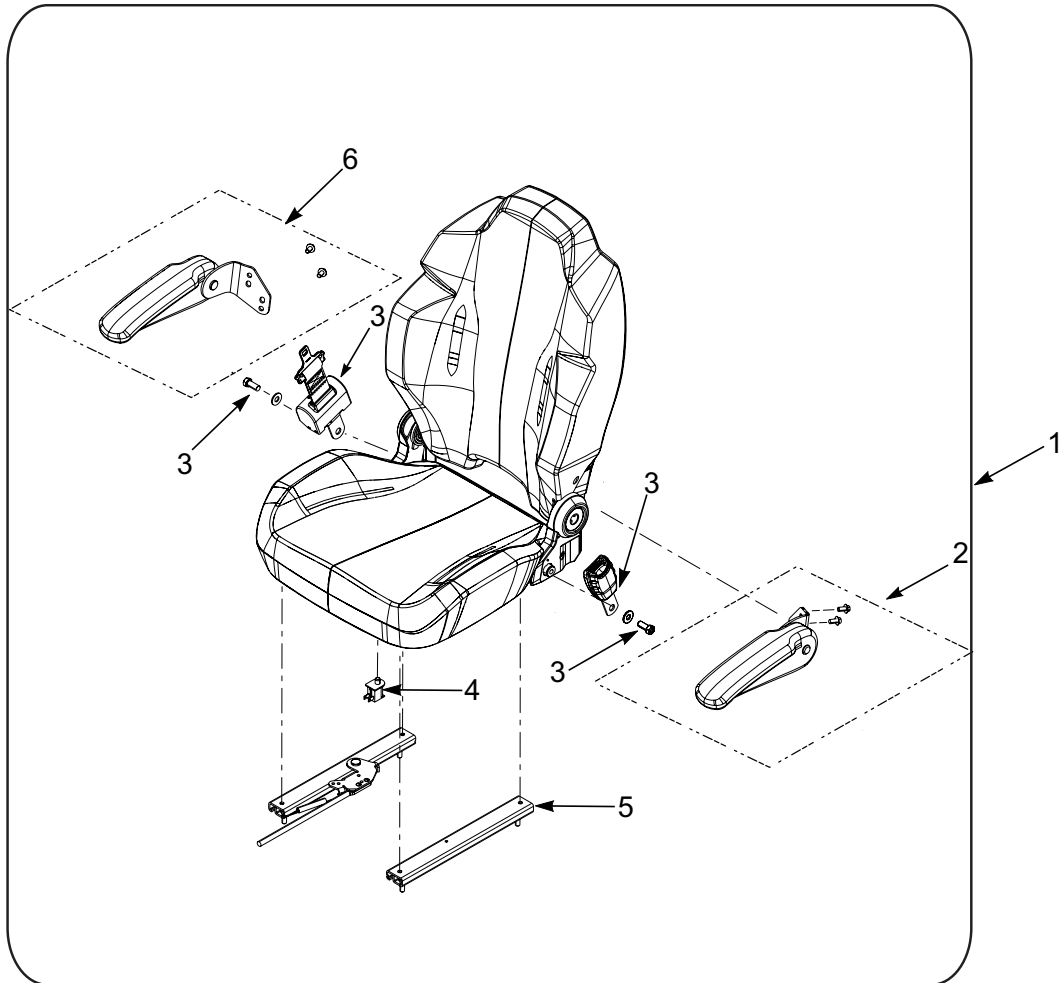

SCZII SEAT ASSEMBLY

Ref. No.	Part No.	Description
1	487076	Seat Assembly - SCZII
2	487272	Armrest Kit, LH
3	487274	Seat Belt Kit
4	481638	Switch, N/O
5	487275	Track Kit
6	487273	Armrest Kit, RH

SCZII SUSPENSION SEAT ASSEMBLY

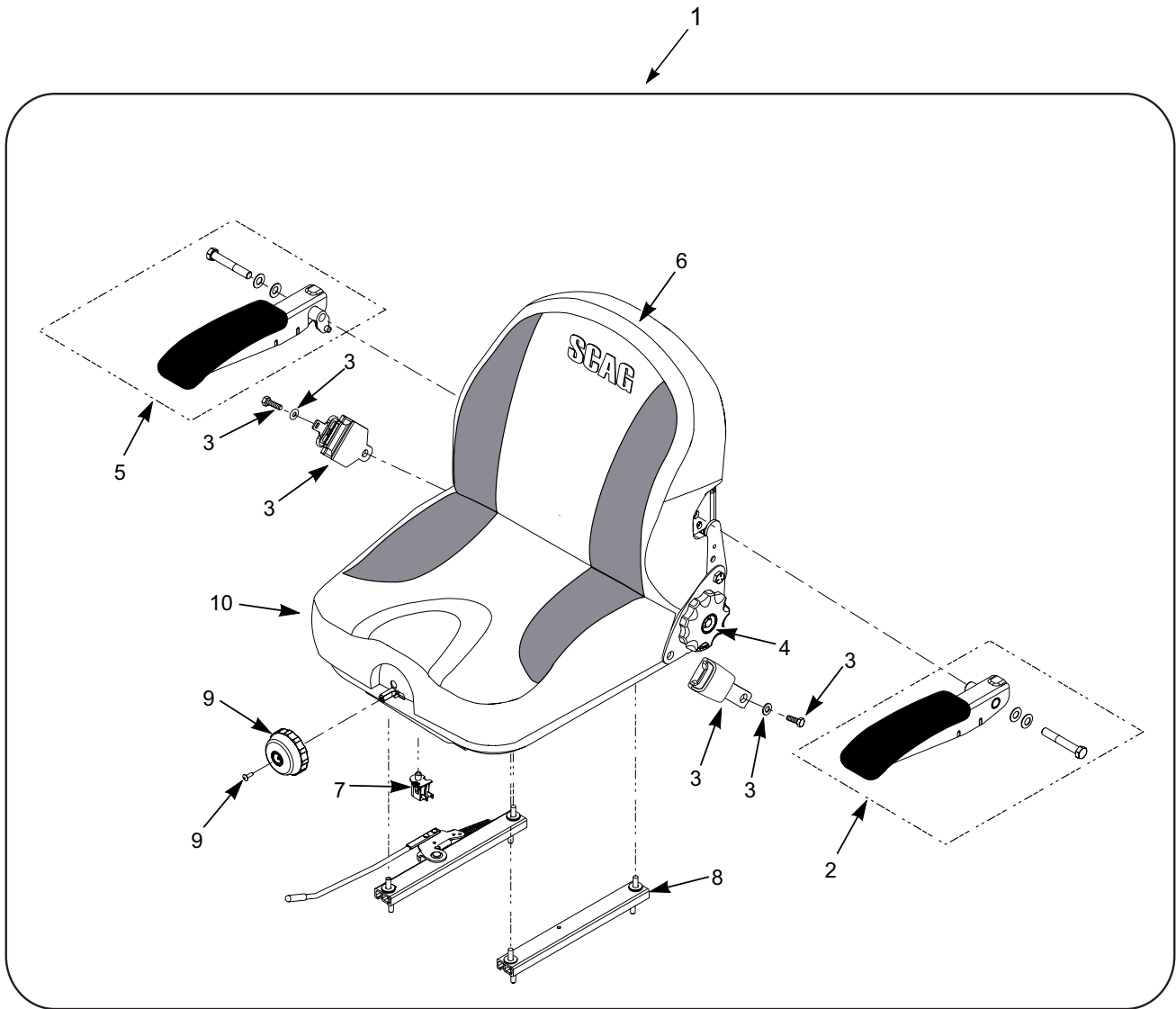

SCZII SUSPENSION SEAT ASSEMBLY

Ref. No.	Part No.	Description
1	486591	Suspension Seat Assembly w/seat belt
2	484709	Armrest Kit, LH
3	484717	Seat Belt Kit
4	485652	Recliner Knob Kit
5	484710	Armrest Kit, RH
6	486596	Cover, Back Cushion
7	481638	Seat Switch
8	485594	Track Kit, (Includes Handle Kit p/n 485717)
9	484714	Suspension Knob Kit
10	486597	Cover, Seat Cushion
11	*484719	Bellows (Track Cover)

SCZII SUSPENSION SYSTEM

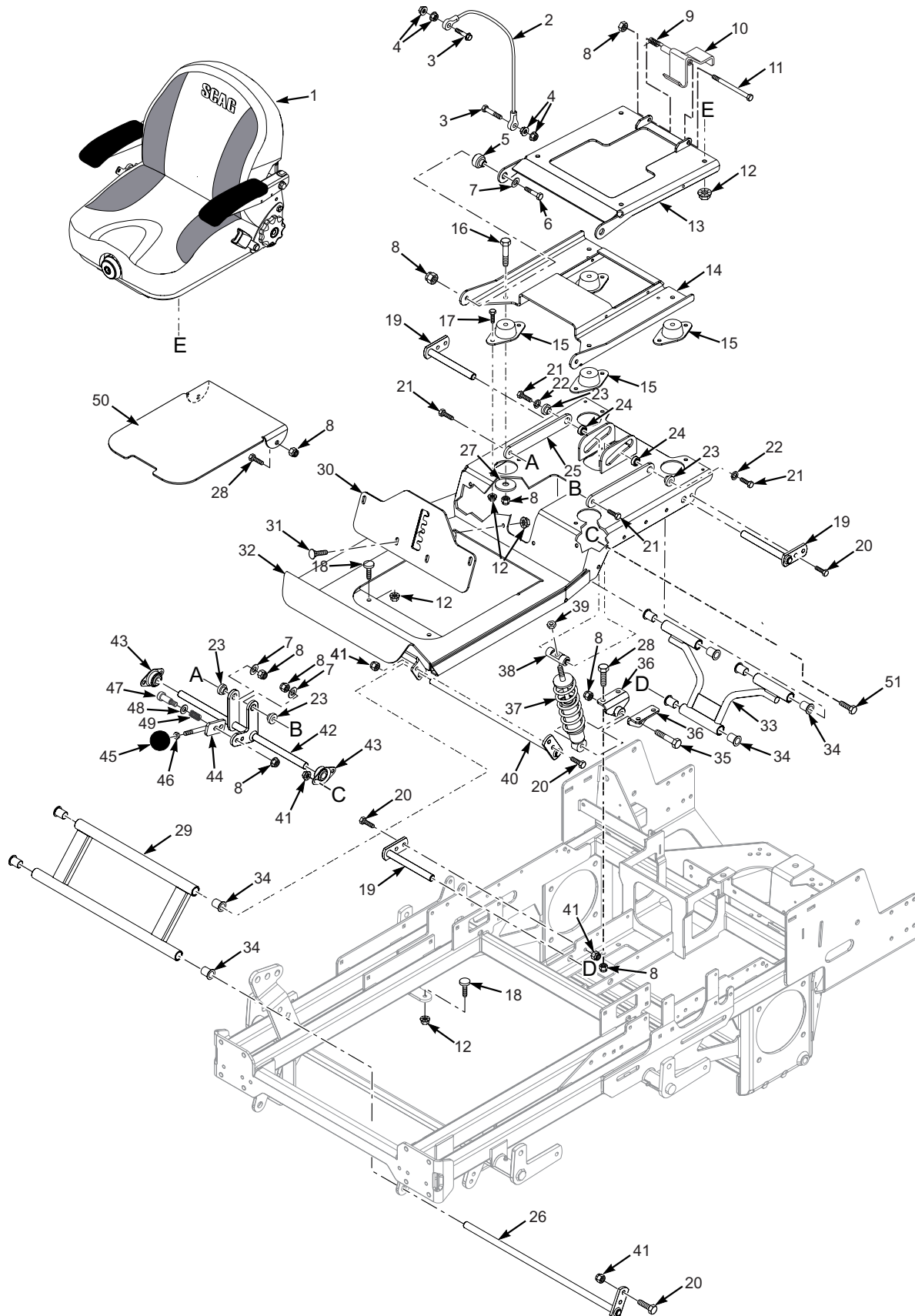

SCZII SUSPENSION SYSTEM

Ref. No.	Part No.	Description
1	486591 487076	Seat Assembly, Suspension Seat Assembly
2	483559	Cable, Seat Stop
3	04001-59	Bolt, Hex Head 1/4-20 x 1-1/4"
4	04019-02	Nut, Serrated Flange 1/4-20
5	43606	Sleeve, Seat Base Mount
6	04001-45	Bolt, Hex Head 3/8-16 x 2"
7	04041-07	Flat washer, 3/8-.391 x .938 x .105
8	04021-09	Nut, Elastic Stop 3/8-16
9	483371	Spring, Seat Latch
10	452143	Latch Weldment, Seat
11	04001-100	Bolt, Hex Head 3/8-16 x 6"
12	04019-03	Nut, Serrated Flange 5/16-18
13	463238-G 463238-B	Seat Plate Weldment (Scag Gold) Seat Plate Weldment (Black)
14	463236-G 463236-B	Seat Mounting Plate w/Decal (Scag Gold) Seat Mounting Plate w/Decal (Black)
15	484148	Isolator, Seat
16	04001-46	Bolt, Hex Head 3/8-16 x 2-1/4"
17	04001-08	Bolt, Hex Head 5/16-18 x 3/4"
18	484201	Bumper, Rubber
19	452152	Shaft Weldment, Rear Op. Platform Pivot
20	04001-09	Bolt, Hex Head 5/16-18 x 1"
21	04001-20	Bolt, Hex Head 3/8-16 x 1-1/2"
22	04030-04	Lock washer, 3/8" Spring
23	43086	Bushing
24	484035	Bearing
25	425257	Link, Suspension Seat Tensioner
26	452150	Pin Weldment, Op Platform Lower Pivot

Ref. No.	Part No.	Description
27	04041-38	Flat washer, 3/8-.406 x 2.25 x .188
28	04001-19	Bolt, Hex Head 3/8-16 x 1"
29	463231	Suspension Pivot Assembly, Front
30	463239	Bracket, Suspension Adjustment w/Decal
31	04003-04	Bolt, Carriage 5/16-18 x 1"
32	463237-G 463237-B	Seat Mounting Base w/Decal (Scag Gold) Seat Mounting Base w/Decal (Black)
33	462212	Suspension Pivot Assembly, Rear
34	483453-14	Bearing
35	04001-22	Bolt, Hex Head 3/8-16 x 2-3/4"
36	452154	Mount Weldment, Shock
37	484032	Shock Absorber, Suspension
38	484150	Mount, Suspension Shock
39	04021-18	Nut, Elastic Stop 3/8-24 Grade 8
40	452151	Pin Weldment, Op Platform Upper Pivot
41	04021-10	Nut, Elastic Stop 5/16-18
42	452107	Pivot Weldment, Suspension Tensioner
43	48796	Bearing, Self Align 5/8" ID
44	452106	Adjustment Lever, Suspension
45	484010	Knob
46	04020-12	Nut, Jam 3/8-16
47	04009-11	Bolt, Shoulder 3/8 x 1"
48	04040-05	Flat washer, 3/8-.406 x .812 x .065
49	483601	Spring
50	428164-G 428164-G	Cover, Foot Plate (Scag Gold) Cover, Foot Plate (Black)
51	04001-08	Bolt, 5/16-18 x 3/4"

SCZII STEERING COMPONENTS

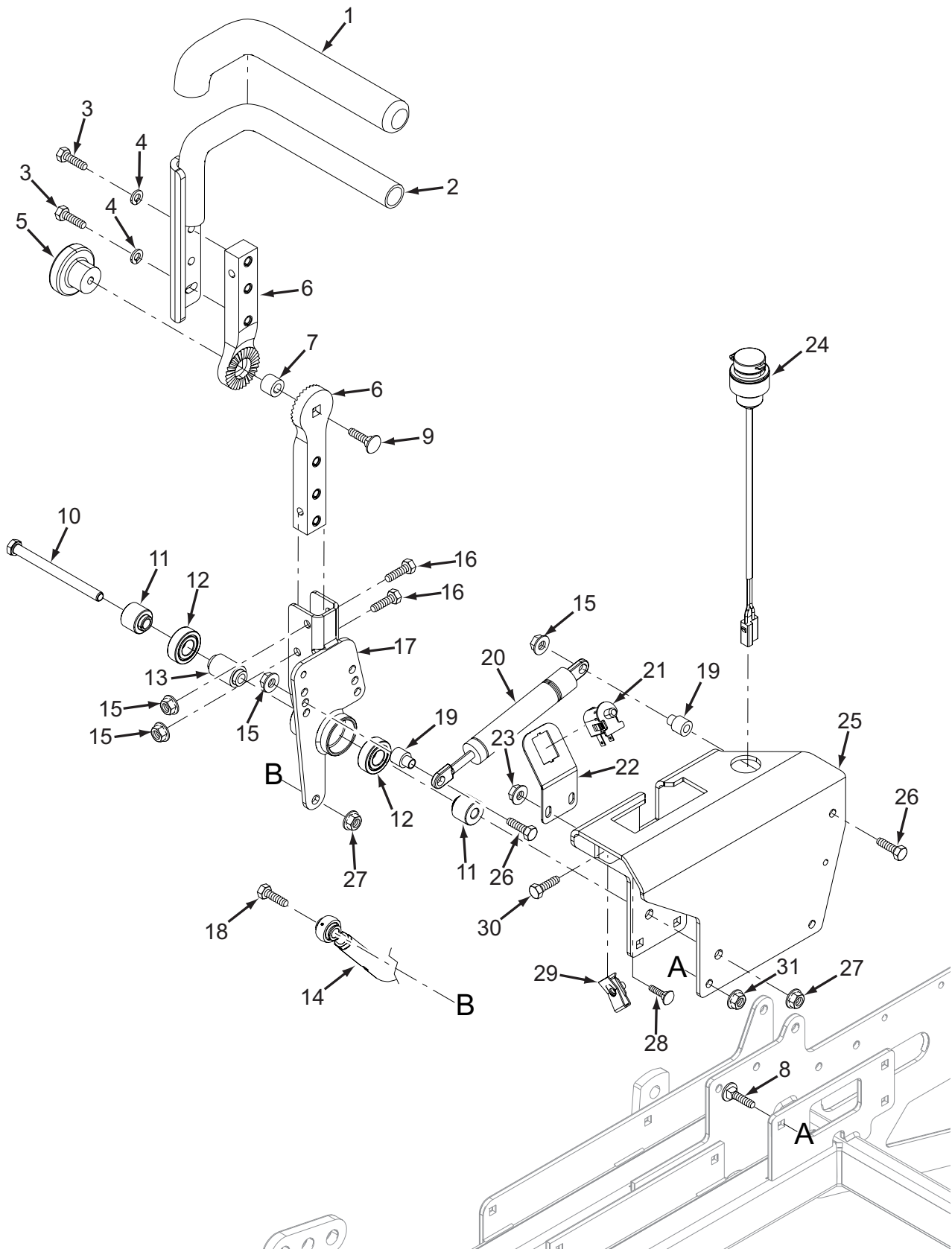

SCZII STEERING COMPONENTS

Ref. No.	Part No.	Description
1	484376	Grip, Control Lever
2	462805	Handlebar w/ Grip RH
	462804	Handlebar w/ Grip LH
3	04001-09	Bolt, 5/16-18 x 1"
4	04030-03	Lock Washer, 5/16
5	483269	Knob, Control Handle
6	483238	Pivot, Control Lever
7	483250	Spacer, Rubber
8	04003-12	Bolt, Carriage, 5/16-18 x 3/4"
9	04003-05	Bolt, Carriage, 3/8-16 x 1-1/2"
10	04001-23	Bolt, 3/8-16 x 4-1/2"
11	43607	Spacer, Controls
12	48224	Ball Bearing, Neutral Ret.
13	43600	Spacer, Bearing
14	486555	Steering Link Assembly, SCZII
	486608	Turnbuckle, 3/8-24
	486609	Rod End, Male Trunion, 3/8-24
	486610	Rod End, Female Trunion, 3/8-24
	04020-26	Nut, 3/8-24 LH Jam
	04020-25	Nut, 3/8-24 Jam
15	04021-10	Nut, Lock Elastic Stop, 5/16-18
16	04001-12	Bolt, 5/16-18 x 1-3/4"
17	453077	Pivot Weldment, Control Arm RH
	453076	Pivot Weldment, Control Arm LH
18	04001-20	Bolt, 3/8-16 x 1-1/2"
19	43602	Spacer, Pump Dampener
20	484193	Dampener, SCZII
21	481638	Switch, N/O
22	425905	Mounting Bracket, Neutral Switch
23	04117-03	Nut, Lock Flanged Elastic Stop, 1/4-20
24	485568	Power Plug, 12V
25	463234	Control Plate w/ Decals RH
	463233	Control Plate w/ Decals LH
26	04001-11	Bolt, 5/16-18 x 1-1/2"
27	04021-09	Nut, Lock Elastic Stop, 3/8-16
28	04003-02	Bolt, Carriage, 1/4-20 x 3/4"
29	04110-03	U-Nut, 3/8-16
30	04107-03	Bolt, 3/8-16 x 1-1/4" w/ Lock
31	04019-03	Nut, Serrated Flange, 5/16-18

SCZII DRIVE SYSTEM COMPONENTS

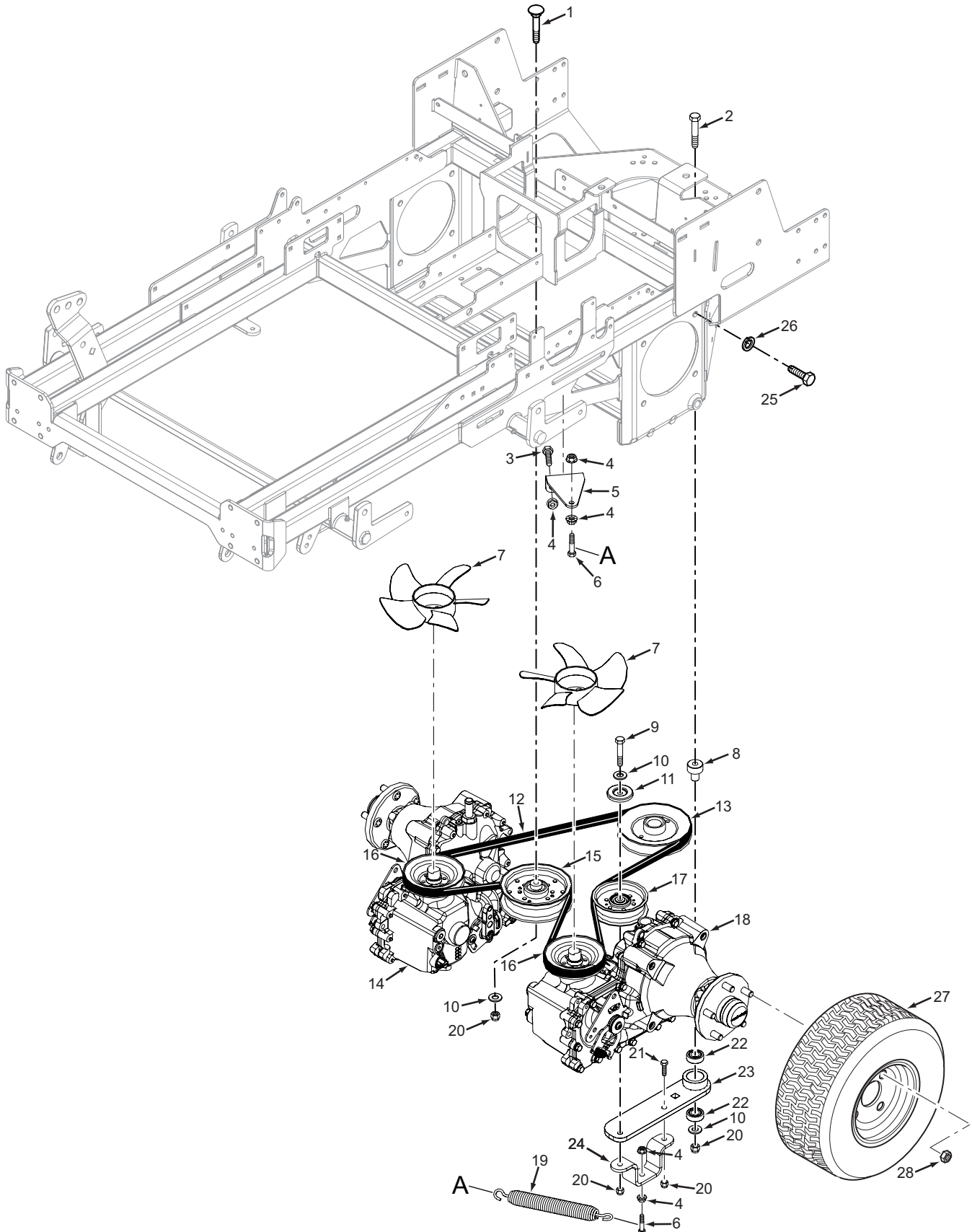

SCZII DRIVE SYSTEM COMPONENTS

Ref. No.	Part No.	Description
1	04003-21	Bolt, Carriage 3/8-16 x 2-1/2"
2	04001-54	Bolt, Hex Head 3/8-16 x 3"
3	04001-19	Bolt, Hex Head 3/8-16 x 1"
4	04019-04	Nut, Serrated Flange 3/8-16
5	425385	Mounting Bracket, Spring - Idler Arm
6	04001-136	Bolt, Hex Head 3/8-16 x 1-1/2" Grade 8
7	HG71906	Kit, Fan / Pulley
8	43504	Pivot, Idler Long
9	04001-22	Bolt, Hex Head 3/8-16 x 2-3/4"
10	04043-04	Flat washer, 3/8-.391 x .938 x .105 HD
11	424367	Dust Shield
12	483165	Belt, Pump Drive
13	484098	Pulley, 5.80" Dia. - 1.125 Bore
14	483798	Transaxle, RH
15	483215	Pulley, 5" Dia. Idler
16	HG71906	Kit, Fan / Pulley
17	484128	Pulley, 4" Dia. Idler
18	483797	Trans axle, LH
19	484202	Spring, Idler Arm
20	04021-09	Nut, Elastic Stop 3/8-16
21	04001-32	Bolt, Hex Head 3/8-16 x 1-1/4"
22	48224	Bearing
23	462259	Idler Arm Assembly (incl. # 22)
24	425386	Mounting Bracket, Idler
25	04001-70	Bolt, Hex Head 1/2-13 x 1-1/4"
26	04030-06	Lock washer, 1/2" Spring
27	484024	Wheel Assembly, 24 x 12-12 4-Ply (5-Hole) - (Scag Gold)
	487422	Wheel Assembly, 24 x 12-12 4-Ply (5-Hole) - (Black)
	484023	Rim w/Valve Stem (Scag Gold)
	487423	Rim w/Valve Stem (Black)
	481852	Tire, 24 x 12-12 4-Ply
28	04028-02	Lug Nut, 1/2-20

SCZII SPEED CONTROL COMPONENTS

Ref. No.	Part No.	Description
1	484093	Knob, Soft Touch
2	04020-12	Nut, Jam 3/8-16 UNC
3	453097	Lever Weldment, Speed Control SCZII
4	04009-11	Bolt, Shoulder 3/8 x 1"
5	04040-05	Flat washer, 3/8-.406 x .812 x .065
6	483601	Spring, Speed Control
7	04009-14	Bolt, Shoulder 3/8 x 3/8"
8	04019-03	Nut, Serrated Flange 5/16-18
9	463233	Control Weldment w/ Decals
10	04001-10	Bolt, Hex Head 5/16-18 x 1-1/4"
11	04003-12	Bolt, Carriage, 5/16-18 x 3/4"
12	04020-14	Nut, 3/8-24 UNF Jam
13	484177	Rod End, 3/8-24
14	04021-04	Nut, Lock Center Lock, 5/16-18
15	484149	Bearing, Self Align
16	04117-01	Nut, FLG HH Elastic Stop 5/16-18
17	04001-08	Bolt, Hex Head 5/16-18 x 3/4"
18	04069-02	Pin, Rue Cotter 1/2" Dia.
19	453066	Speed Control Bellcrank Weldment
20	486500	Speed Linkage Assembly (INCL. 12,13,21,22
21	04021-27	Nut, Elastic Stop 3/8-24
22	484175	Spring
23	04041-45	Flat washer, 3/8-.376/.380 x .734 x .063
24	485317	Bushing, Pivot

SCZII BRAKE COMPONENTS

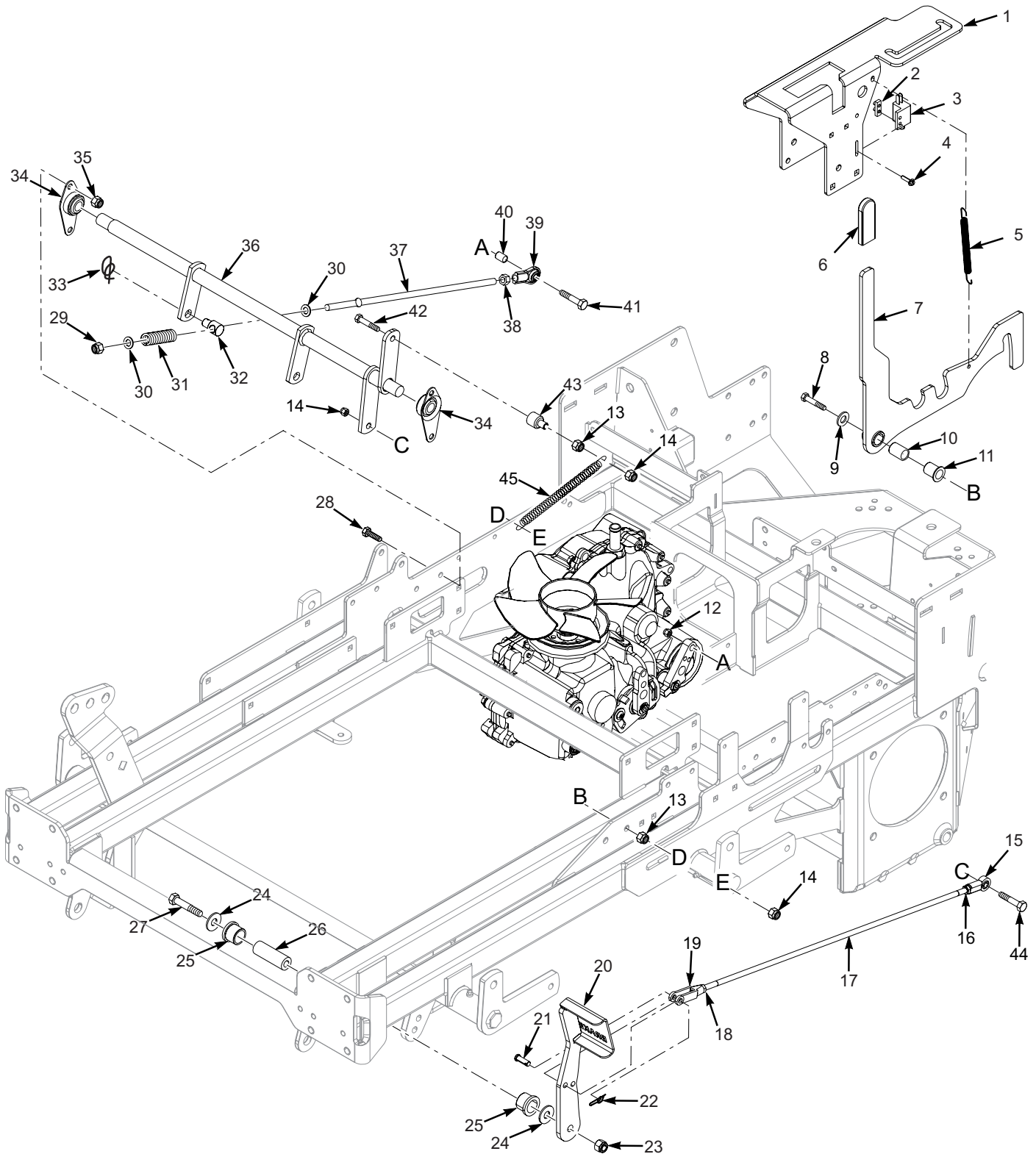

SCZII BRAKE COMPONENTS

Ref. No.	Part No.	Description
1	463233	Control Weldment w/ Decal
2	422373	Plate, Threaded
3	486616	Switch, N/C
4	04010-12	Screw, #10-32 x .75
5	483600	Spring, Brake
6	482102	Grip, Brake Lever
7	463192	Brake Lever w/ Grip
8	04001-31	Bolt, 3/8-16 x 2-1/2"
9	04043-04	Flat Washer, 3/8 - .391 x .938 x .105
10	431047	Pivot, Brake Lever
11	483453-14	Bearing, .625 ID
12	04021-04	Nut, Lock Center Lock, 5/16-18
13	04021-05	Nut, Lock Center Lock, 3/8-16
14	04021-09	Nut, Lock Elastic Stop, 3/8-16
15	48544	Rod End, 3/8-24 LH Thd
16	04020-26	Nut, 3/8-24 LH Jam
17	486575	Brake Rod Assembly (INCL. 15,16,18,19)
18	04020-25	Nut, 3/8-24 Jam
19	48343-04	Clevis, 3/8-24
20	453138	Brake Pedal
21	04064-02	Clevis Pin, 3/8 x 1.06
22	04069-01	Pin, Rue Cotter - 3/8 Dia
23	04021-07	Nut, Lock Elastic Stop, 1/2-13
24	04040-13	Flat Washer, 1/2- .562 x 1.375 x .109
25	483453-03	Bearing, 1" ID
26	43872	Sleeve, Brake Pivot
27	04001-194	Bolt, 1/2-13 x 4-1/4"
28	04001-08	Bolt, 5/16-18 x 3/4"
29	04021-27	Nut, Lock Elastic Stop, 3/8-24
30	04041-45	Flat Washer, 3/8 - .376/.380 x .734 x .063
31	484182	Spring, Lower Brake
32	485317	Bushing, Pivot Slide
33	04069-02	Pin, Rue Cotter - 1/2" Dia
34	484149	Bearing, Self Align
35	04117-01	Nut, Lock Flange Elastic Stop, 5/16-18
36	453067	Brake Linkage Weldment
37	485321	Brake Linkage Assembly (INCL. 29,30,31,32,38,39)
38	04020-14	Nut, 3/8-24
39	484177	Rod End, 3/8-24 Thd 5/16 Bore
40	43749	Spacer, V-link
41	04001-195	Bolt, 5/16-18 x 2-1/2"
42	04001-22	Bolt, 3/8-16 x 2-3/4"
43	43503	Pivot, Idler - Short
44	04001-26	Bolt, 3/8-16 x 1-1/4"
45	481343	Spring, Hopper Door

SCZII HYDRAULIC SYSTEM

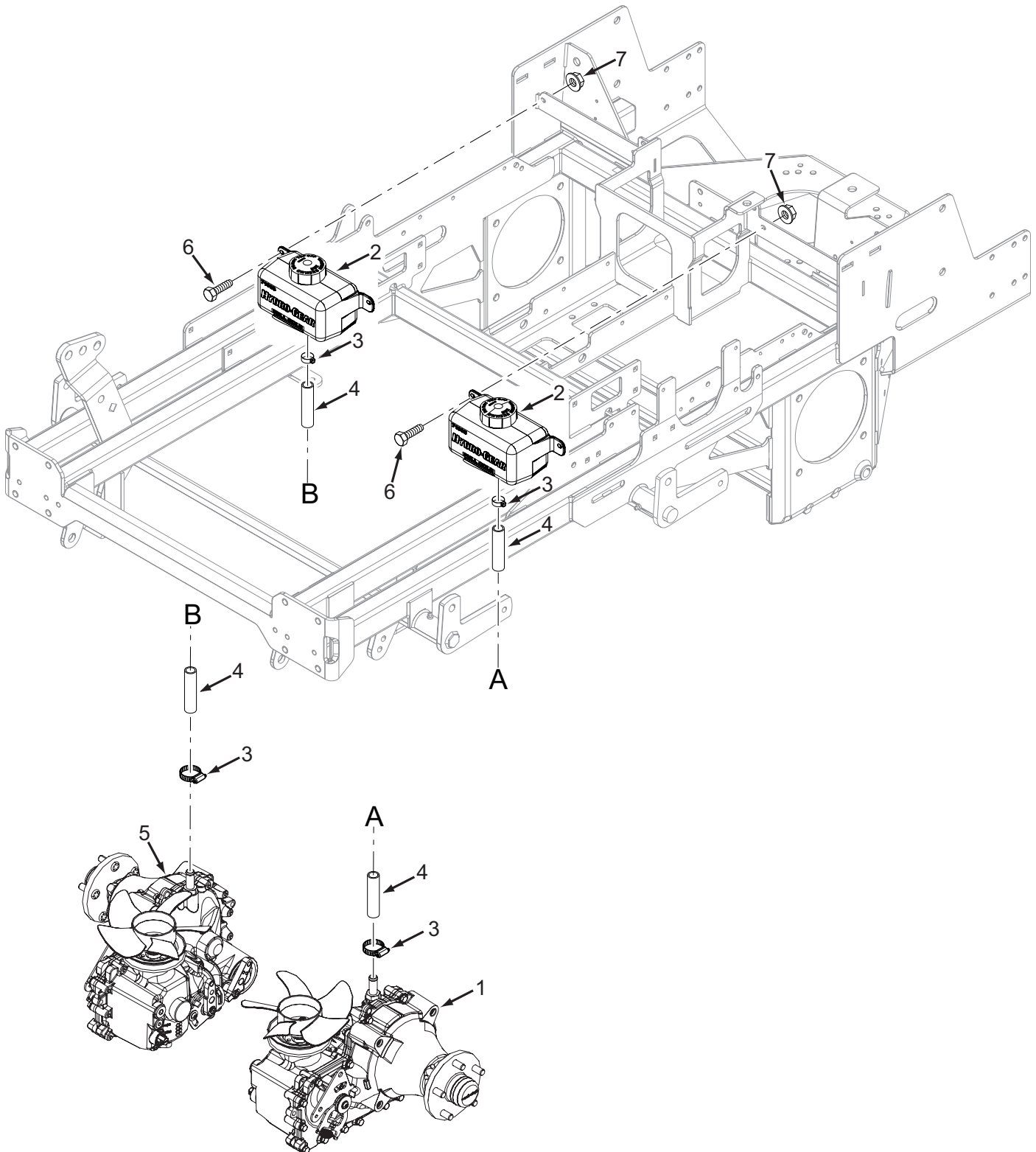

SCZII HYDRAULIC SYSTEM

Ref. No.	Part No.	Description
1	483797	Trans axle, LH
2	486568	Hydraulic Tank, 1,000 ml
3	48136-16	Clamp, 1" Max Dia.
4	48504	Hose, 5/8 Pushlock (order by inch)
5	483798	Trans axle, RH
6	04001-01	Bolt, 1/4-20 x 3/4"
7	04019-02	Nut, Serrated Flange, 1/4-20

SCZII FUEL SYSTEM

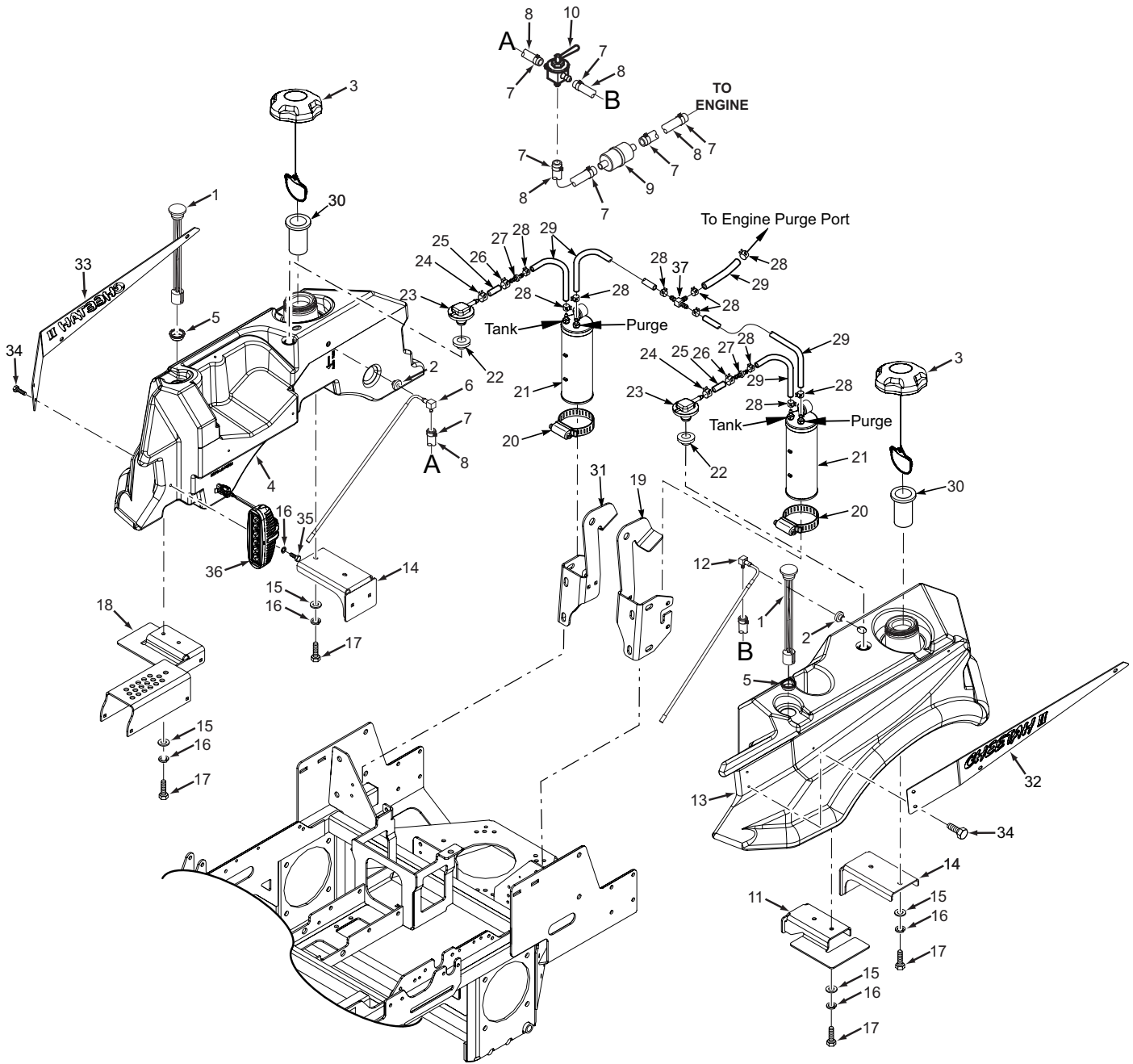

SCZII FUEL SYSTEM

Ref. No.	Part No.	Description
1	484243	Fuel Gauge
2	482571	Bushing, .56 Dia. Viton
3	484286	Fuel Cap, Tethered
	484297	Fuel Cap w/Tethered - California Models Only (not shown)
4	463273	Fuel Tank Assembly, RH (incl. #1, 2, 5, 6, 22, 23)
5	484242	Grommet
6	484553	Fuel Tube Assembly, RH
7	48059-01	Clamp, Fuel Hose 1/4" ID
8	483617	Fuel Hose, 1/4" Non-Perm (order by inch)
9	**	Fuel Filter
10	482212	Valve, Fuel Shut-Off
11	428233	Mounting Bracket, Fuel Tank Front
12	484552	Fuel Tube Assembly, LH
13	463272	Fuel Tank Assembly, LH (incl. #1, 2, 5, 12, 22, 23)
14	428261	Mounting Bracket, Fuel Tank Rear
15	04040-15	Flat washer, 5/16-.375 x .875 x .083
16	04030-03	Lock washer, 5/16" Spring
17	04001-08	Bolt, Hex Head 5/16-18 x 3/4"
18	463235-G	Adjustment Bracket, Upper Cut Height (Scag Gold)
	463235-B	Adjustment Bracket, Upper Cut Height (Black)
19	427177	Rops Mounting Bracket LH
20	48136-17	Clamp
21	484342	Carbon Canister
	484366	Dust Filter, Carbon Canister
22	484285	Grommet, Viton
23	484333	Remote Vent
24	48059-02	Clamp, Fuel Hose 7/32"
25	484347	Hose, 1/4" Vapor Recovery (order by inch)
26	48059-02	Clamp, Fuel Hose 7/32"
27	484343-01	Mender, 1/4 x 3/16 w/.02 Hole
28	48059-05	Clamp, Vapor Recovery Hose 3/16"
29	484345	Hose, 3/16"
30	484279-01	Tube, Fuel Tank Insert
31	427178	Rops Mounting Bracket RH
32	428229	Plate, LH Fuel Tank
33	428195	Plate, RH Fuel Tank
34	04017-04	Bolt, Serrated Flange 1/4-20 x 1/2"
35	04015-11	Screw, 5/16-18 x 3/4"
36	486672	Light Assembly
37	48935-02	Tee, 3/16 x 3/16 x 3/16 Union - Hose Barb

** Available through the individual engine manufacturer.

SCZII ENGINE & ATTACHING PARTS

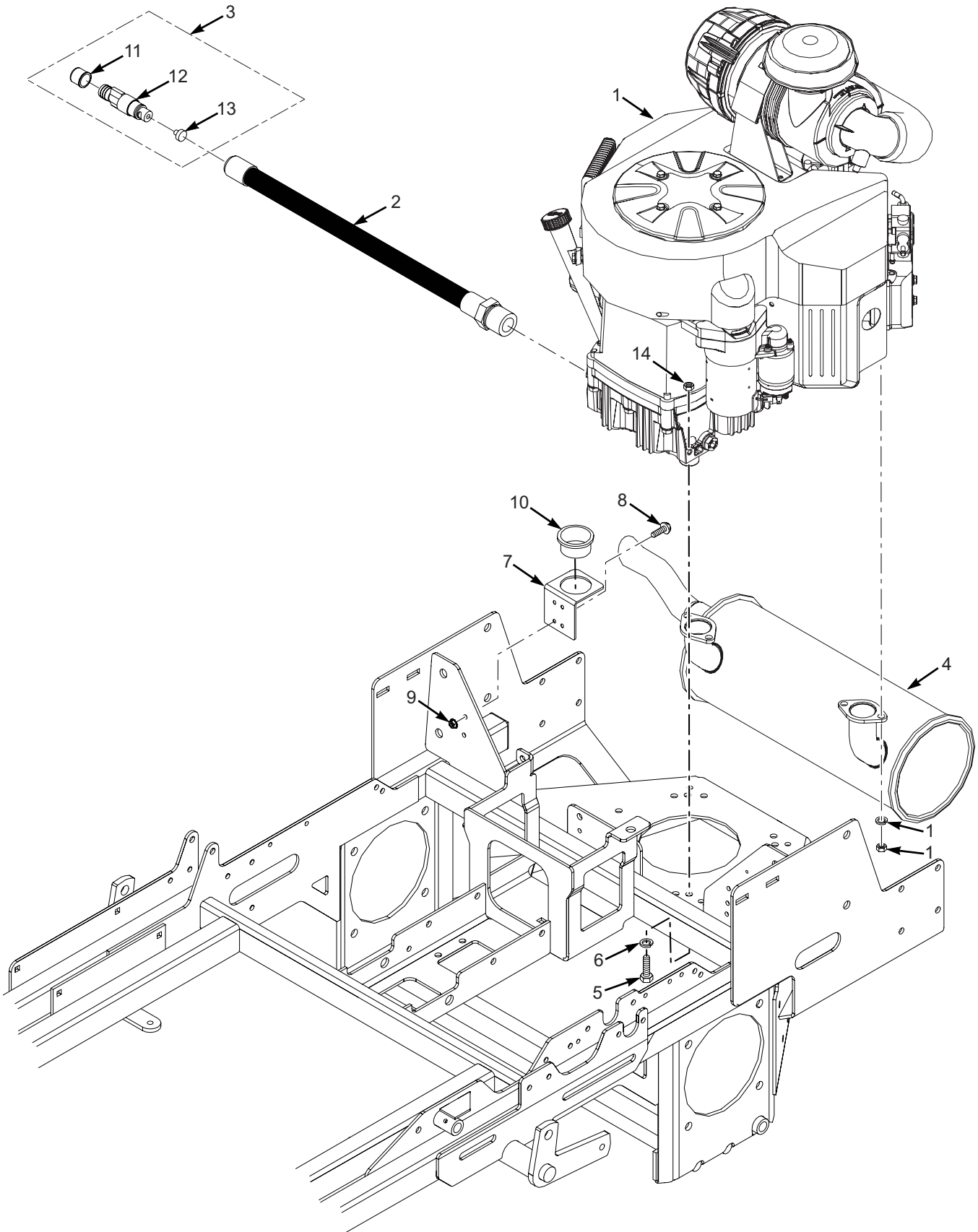

SCZII ENGINE & ATTACHING PARTS

Ref. No.	Part No.	Description
1	**485033	Engine, Kawasaki 31FX - (FX921)
	**486726	Engine, Kawasaki 38FX-EFI (FX1000)
	**486516	Engine, Briggs & Stratton 37 BV-EFI (#61A7)
	**487604	Engine, Briggs & Stratton 40BV-EFI (#61G8)
	**487294	Engine, Kohler 38CV-EFI (ECV940)
	**487615	Engine, Briggs & Stratton 36 HP BV
2	484581	Hose, Oil Drain, Kawasaki (incl. # 3)
	484599	Hose, Oil Drain, Briggs & Stratton (incl. # 3)
	484597	Hose, Oil Drain, Kohler (incl. # 3)
	***484706	Hose, Oil Drain, Briggs & Stratton (incl. # 3)
3	484583	Valve Assembly, Oil Drain
4	486648	Muffler, Kawasaki - FX921
	*486660	Pipe, Muffler Extension - FX921 / 38CV-EFI
	*48633	Muffler Clamp - FX921
	486108	Muffler, Briggs & Stratton - 37 BV-EFI
	*486659	Pipe, Muffler Extension - 37 BV-EFI / 40BV-EFI
	*484291	Clamp, Muffler - 1-3/4" - 37 BV-EFI / 38CV-EFI / 40BV-EFI
	487617	Muffler, Briggs & Stratton 40BV-EFI
	487293	Muffler, Kohler - 38CV-EFI
5	04001-32	Bolt, 3/8-16 x 1-1/4"
	04001-20	Bolt, 3/8-16 x 1-1/2" (37BV-EFI / 38CV-EFI)
6	04030-04	Lock washer, 3/8" Spring (31FX)
7	425975-G	Bracket, Oil Drain Hose (Scag Gold)
	425975-B	Bracket, Oil Drain Hose (Black)
8	04010-32	Screw, #8-32 x 5/8"
9	04021-17	Nut, Elastic Stop #8-32
10	484617	Bushing, Thick Panel Snap
11	484585	Cap
12	48603-12	O-Ring
13	484586	Seal
14	04134-03	Nut, Lock Flange Top Lock, 3/8-16 (37BV-EFI / 38CV-EFI)

* Not Shown

** Available through the individual engine manufacturer.

ZT-5400 TRANSAXLE ASSEMBLY

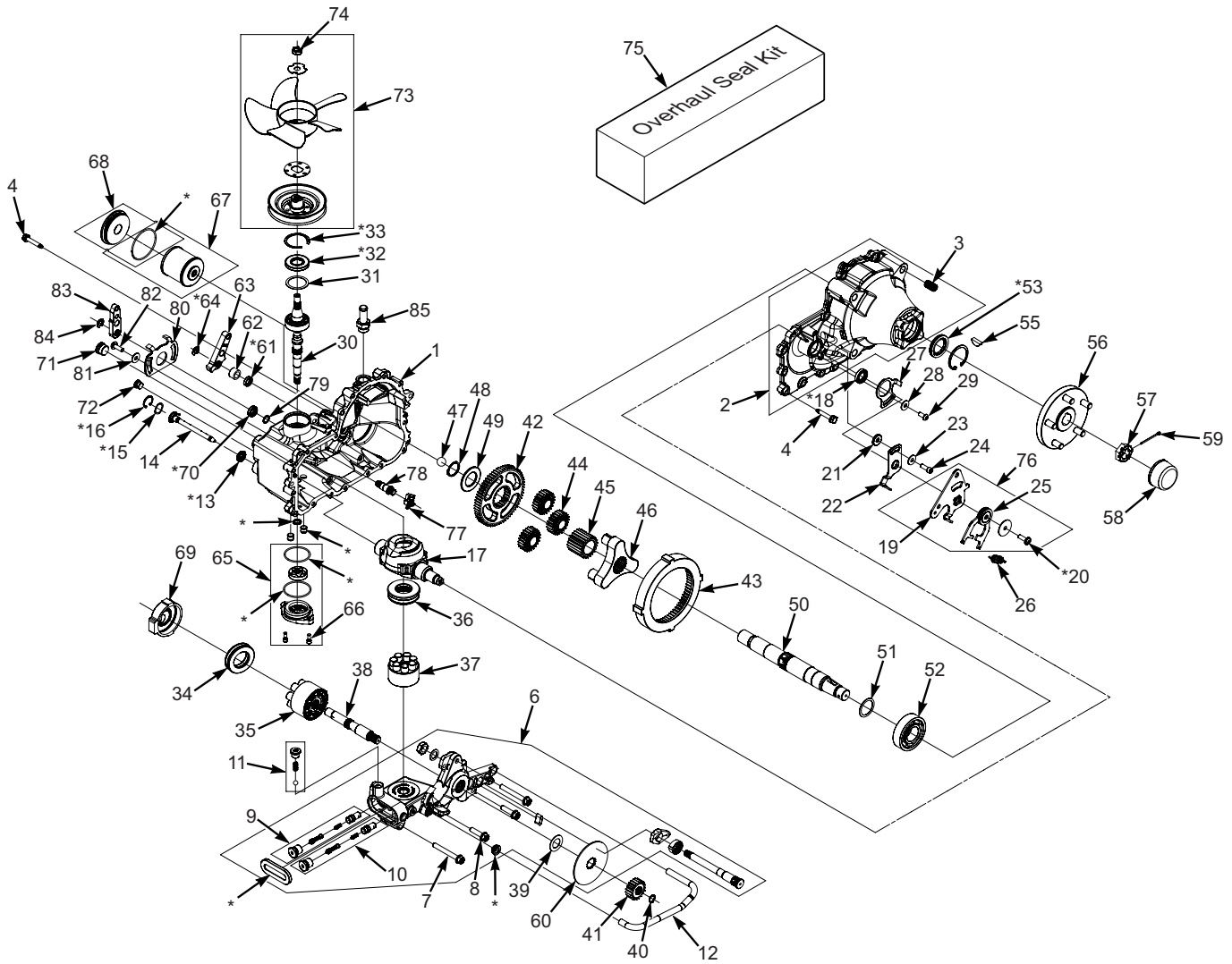

* - Included with Seal Kit Item # 75

ZT-5400 TRANSAXLE ASSEMBLY

Ref. No.	Part No.	Description
1	HG71946	Kit, Housing Main, LH
	HG71947	Kit, Housing Main, RH
2	HG71948	Kit, Housing Side, LH
	HG71948	Kit, Housing Side, RH
3	HG52973	Insert, 1/2-13 x 1-1/2" UNC
4	HG52974	Screw, Hex Flange 5/16-18 x 1-1/2"
5	HG50928	Tube, Sealant
6	HG71995	Kit, Center Section, LH
	HG71996	Kit, Center Section, RH
7	HG52977	Bolt, Hex Flange 3/8-16 x 3"
8	HG52137	Screw, Hex Flange Head 3/8-16 x 1-1/2"
9	HG71952	Kit, Shock Valve
10	HG71952	Kit, Shock Valve
11	HG71999	Kit, Charge Relief
12	HG52984	Tube, Filter, LH
	HG52983	Tube, Filter, RH
13	HG53197	Seal, Lip 12x 24 x 5 TC
14	HG71940	Kit, Bypass Actuator
15	HG53321	Spring, Wave
16	HG53322	Ring, Retaining, HO-100
17	HG52972	Swash Plate, 16cc. Machined
18	HG52989	Seal, Lip 22 x 32 x 7
19	HG53222	Arm, Control, LH
	HG53221	Arm, Control, RH
20	HG51812	TWHCS, 5/16-18 x 1" (Patch)
21	HG52527	Spacer, .320 x 1.005 x .179
22	HG51946	Arm, Neutral, LH
	HG51945	Arm, Neutral, RH
23	HG44130	Washer, .34 x .88 x .06
24	HG51616	SHCS, 5/16-24 x .875 (Patch)
25	HG52433	Assembly, RTN Uni-Directional (CCW) LH
	HG52434	Assembly, RTN Uni-Directional (CW) RH
26	HG51605	Spring, Extension, RTN - 44lbs
27	HG53190	Plate, Stop, LH
	HG53189	Plate, Stop, RH
28	HG44130	Washer, .34 x .88 x .06
29	HG53519	HBHCS, 5/16-18 x 3/4"
30	HG71941	Kit, Input Shaft
31	HG51279	Spacer
32	HG51280	Seal, Lip 25 x 52 x 7 TC
33	HG52650	Ring, Retaining Internal
34	HG53341	Bearing, Thrust 42 x 68 x 16
35	HG70082	Kit, Cylinder Block - 21cc.
36	HG52991	Bearing, Thrust 35 x 70 x 22
37	HG70735	Kit, Cylinder Block - 16cc.
38	HG52992	Shaft, Motor
39	HG52993	Washer, .89 x 1.50 x .04
40	HG44145	Ring, Retaining
41	HG52994	Gear, 19T
42	HG52996	Gear, 65T
43	HG52998	Gear, Ring 68T
44	HG52999	Gear, Planet 23T
45	HG53000	Gear, Sun 22T

Ref. No.	Part No.	Description
46	HG53001	Carrier
47	HG53002	Ball, Thrust .75
48	HG53003	Ring, Retaining 1-1/4"
49	HG53004	Spacer, Thrust, Axle
50	HG53005	Shaft, Axle
51	HG53006	Washer, 1.40 x 1.75 x .05
52	HG53007	Bearing, Ball 35 x 80 x 21
53	HG53008	Seal, Lip 1.375 x 2.062 x .250
54	HG50859	Ring, Retaining Internal
55	HG51796	Key, Shaft, Axle
56	HG72039	Kit, Hub, 5-Bolt
57	HG51821	Nut, Hex 1-20 Slotted
58	HG53724	Cap, Axle
59	HG51822	Pin, Cotter 9/64 x 2"
60	HG53012	Rotor, Brake
61	HG53015	Seal, .56 x .88 x .19
62	HG53356	Spacer, .57 x .86 x .53
63	HG53018	Handle, Actuating
64	HG53019	Ring, Retaining
65	HG71942	Kit, Charge Cover
66	HG9007300-2510	Screw, 1/4-20 x .625
67	HG71943	Kit, Filter
68	HG71944	Kit, Filter Plug
69	HG53026	Plate, Motor Swash
70	HG9008000-0127	Seal, 15 x 24 x 7
71	HG9005110-8700	Plug, 7/8-14
72	HG9005110-5600	Plug, 9/16-18
73	HG71906	Kit, Fan/Pulley
74	HG44133	Nut, Hex 1/2-20 w/Patch
75	HG73190	Seal Kit
76	HG72002	Kit, RTN Bi-Directional LH
	HG72001	Kit, RTN Bi-Directional RH
77	HG53028	Cam, 2-Speed
78	HG53029	Shaft, 2-Speed, Bevel
79	HG53030	Ring, Retaining External .59"
80	HG53034	Arm, Lock Down 2-Speed
81	HG44130	Washer, .34 x .88 x .06
82	HG53519	HBHCS, 5/16-18 x 3/4"
83	HG53193	Handle, Actuating
84	HG53019	Ring, Retaining External .375"
85	HG53037	Fitting, 7/8-14 SAE, .625 Beaded

SCZII ELECTRICAL SYSTEM

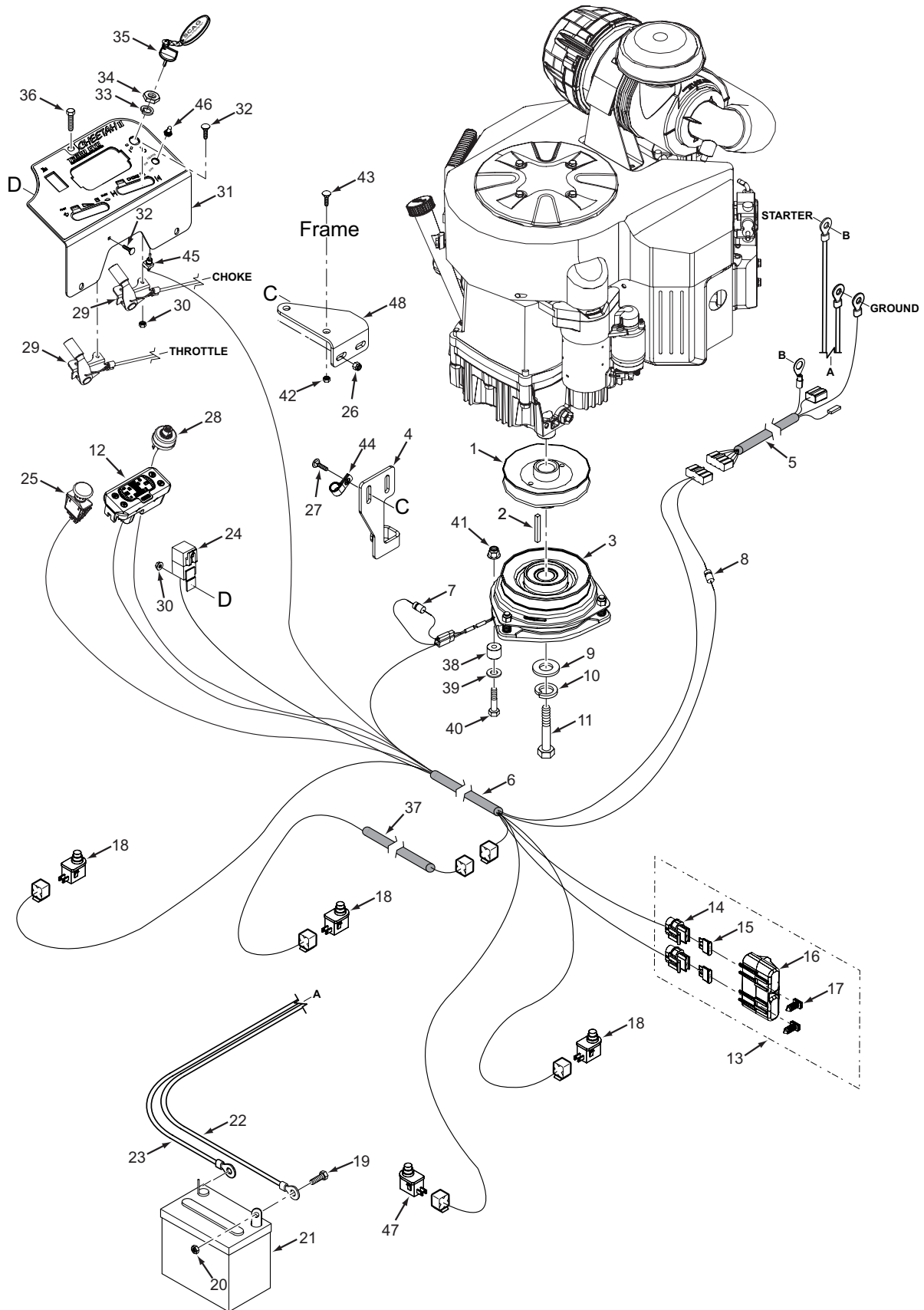

SCZII ELECTRICAL SYSTEM

Ref. No.	Part No.	Description
1	484098	Pulley, 5.80 Dia. - 1.125 Bore
2	04063-23	Key, 1/4 x 1/4 x 3-1/4"
3	461826	Electric Clutch w/Tag - GT-5 (FX921)
4	426950	Bracket, Anti-Rotation
5	485678	Wire Harness Adapter, Kawasaki
	487840	Wire Harness Adapter, Briggs & Stratton 36BV
6	486503	Wire Harness, SCZII
7	483958	Diode, 600V - 6A
8	482253	Diode
9	04041-28	Flat washer, 7/16-.469 x 1.75 x .25
10	04030-05	Lock washer, 7/16" Spring
11	04102-03	Bolt, Hex Head 7/16-20 x 2-1/4" w/Patch
12	484721	Tiger Eye Cluster Gauge
13	483642	Double Fuse Assembly (incl. # 14, 15, 16, 17)
14	483629	Fuse Holder
15	48298	Fuse, 20 Amp
16	483571	Cover, Sealed Double
17	482588	Clip, Wire
18	481638	Switch, N.O.
19	04001-44	Bolt, Hex Head 1/4-20 x 1/2"
20	04020-02	Nut, 1/4-20
21	*	Battery
22	48029-11	Battery Cable, 27" Black
23	48029-13	Battery Cable, 25" Red
	**48126	Rubber Boot
24	483013	Relay
25	485833	Switch, PTO - 10 Amp
26	04117-01	Nut, FLF HH Elastic Stop 5/16-18
27	04003-04	Bolt, Carriage 5/16-18 x 1"
28	48798	Keypad w/Hardware
29	481544	Control Cable (Kawasaki FX921 Choke Cable)
	481363	Control Cable (Kawasaki FX921 Throttle Cable)
30	04021-26	Nut, Elastic Stop #10-24
31	463241	Instrument Panel w/Decal
32	04003-43	Bolt, Carriage #10-24 x 1/2"
33	48017-03	Lock washer, 5/8" Internal
34	48017-04	Nut, Hex 5/8-32
35	462069	Key Assembly w/Fob
36	04017-04	Bolt, Hex Head 1/4-20 x 1/2" Serrated Flange
37	484722	Wire Harness, Operator Platform -SCZII
38	431009	Bushing, UHMW
39	04040-15	Flat washer, 5/16-.375 x .875 x .083
40	04001-11	Bolt, Hex Head 5/16-18 x 1-1/2"
41	04021-10	Nut, Lock Elastic Stop, 5/16-18
42	04019-04	Nut, Serrated Flange, 3/8-16
43	04003-23	Bolt, Carriage, 3/8-16 x 1"
44	48030-09	Clamp, Cable - 1/2" ID
45	483120	Switch, On/Off
46	483121	Boot, Switch
47	486616	Switch, N/C
48	425392	Bracket, Anti-Rotation

* Not available through Scag

** Not Shown

SCZII EFI ELECTRICAL SYSTEM

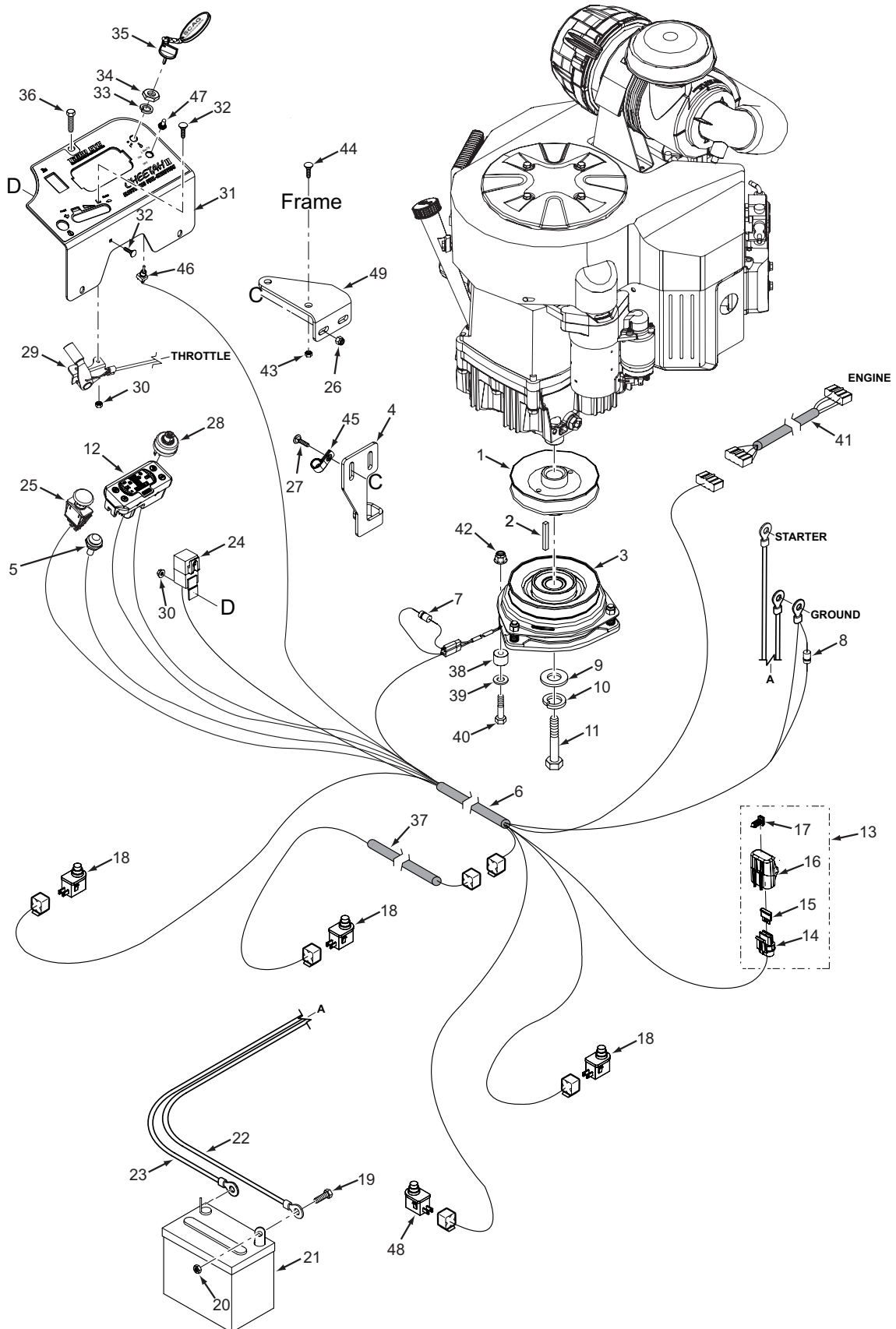

SCZII EFI ELECTRICAL SYSTEM

Ref. No.	Part No.	Description
1	484098	Pulley, 5.80 Dia. - 1.125 Bore
2	04063-23	Key, 1/4 x 1/4 x 3-1/4"
3	461826	Electric Clutch w/Tag - GT-5
4	426950	Bracket, Anti-Rotation
5	481182	Indicator Light Assembly
6	487408	Wire Harness, SCZII-EFI
	486753	Wire Harness, SCZII-FX-EFI
7	483958	Diode, 600V - 6A
8	482253	Diode
9	04041-28	Flat washer, 7/16-.469 x 1.75 x .25
10	04030-05	Lock washer, 7/16" Spring
11	04102-03	Bolt, Hex Head 7/16-20 x 2-1/4" w/Patch
12	484721	Tiger Eye Cluster Gauge
13	485739	Fuse Assembly (incl. # 14, 16, 17)
14	483629	Fuse Holder
15	48298	Fuse, 20 Amp
16	483643	Cover, Sealed Single
17	482588	Clip, Wire
18	481638	Switch, N.O.
19	04001-44	Bolt, Hex Head 1/4-20 x 1/2"
20	04020-02	Nut, 1/4-20
21	*	Battery
22	48029-07	Battery Cable, 18" Black (37BV-EFI / 38CV-EFI)
	48029-11	Battery Cable, 27" Black (38FX-EFI)
23	48029-28	Battery Cable, 26" Red (w-brade)
	**48126	Rubber Boot
24	483013	Relay
25	485833	Switch, PTO - 10 Amp
26	04117-01	Nut, FLF HH Elastic Stop 5/16-18
27	04003-04	Bolt, Carriage 5/16-18 x 1"
28	48798	Keyswitch w/Hardware
29	481544	Control Cable (38CV-EFI)
	485464	Control, E-Gov Throttle (37BV-EFI, 38FX-EFI, 40BV-EFI)
	483533	Knob, Throttle Control (38FX-EFI) (not shown)
30	04021-26	Nut, Elastic Stop #10-24
31	463240	Instrument Panel w/Decal
32	04003-43	Bolt, Carriage #10-24 x 1/2"
33	48017-03	Lock washer, 5/8" Internal
34	48017-04	Nut, Hex 5/8-32
35	462069	Key Assembly w/Fob
36	04017-04	Bolt, Hex Head 1/4-20 x 1/2" Serrated Flange
37	484722	Wire Harness, Operator Platform -SCZII
38	431009	Bushing, UHMW
39	04040-15	Flat washer, 5/16-.375 x .875 x .083
40	04001-11	Bolt, Hex Head 5/16-18 x 1-1/2"
41	486139	Wire Harness Adapter, Briggs & Stratton 37 BV-EFI / Kohler 38CV-EFI
42	04021-10	Nut, Lock Elastic Stop, 5/16-18
43	04019-04	Nut, Serrated Flange, 3/8-16
44	04003-23	Bolt, Carriage, 3/8-16 x 1"
45	48030-09	Clamp, Cable - 1/2" ID
46	483120	Switch, On/Off
47	483121	Boot, Switch
48	486616	Switch, N/C
49	425392	Bracket, Anti-Rotation

* Not available through Scag

** Not Shown

REPLACEMENT DECALS AND INFORMATION PLATES



1

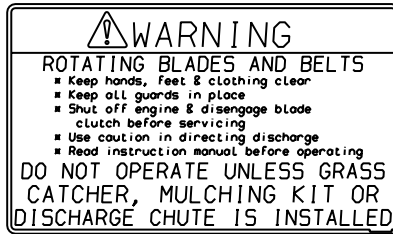

2



8

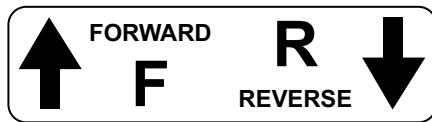

6

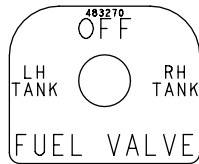

10



3



9

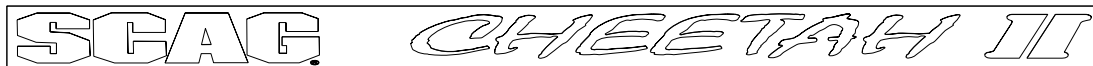

11

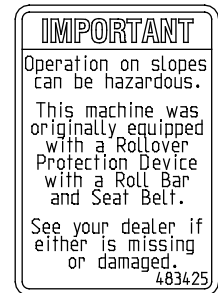

5

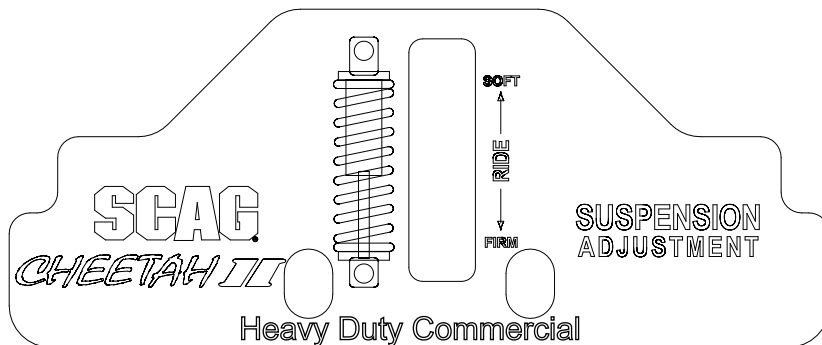

12



13



14

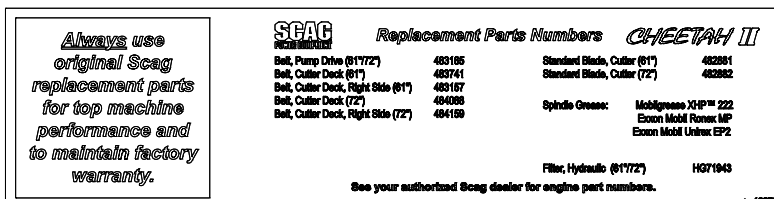

19

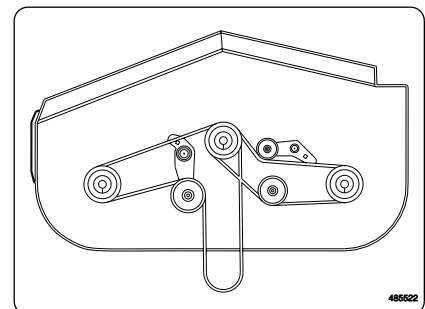

485822

20

REPLACEMENT DECALS AND INFORMATION PLATES

Ref. No.	Part No.	Description
1	483407	Decal, Spinning Blades
2	483406	Decal, Knives
3	483201	Decal, 61" Velocity Plus
	484574	Decal, Velocity Plus - 61RD
	483693	Decal, 72" Velocity Plus
	487907	Decal, 72RD Velocity Plus
4	483633	Decal, Seat Replacement
5	483425	Decal, ROPS
6	482100	Decal, Traction Control
7	483405	Decal, Warning
8	485403	Decal, Made in USA
9	483402	Decal, Belt Cover
10	487419	Decal, Fuel Shut Off
11	487410	Decal, Scag Cheetah II
12	486580	Decal, Suspension Adjustment
13	487420	Decal, Deck Height - LH
14	487421	Decal, Deck Height - RH
15	486510	Decal, Instrument Panel - SCZII - EFI
16	486613	Decal, Speed Control
17	483443	Decal, Start / Drive
18	486612	Decal, Adjustments - SCZII
19	487411	Decal, SCZII Replacement Parts
20	485522	Decal, SCZII Belt Routing
	485523	Decal, SCZII Belt Routing 61RD
21	486559	Decal, Scag - Fuel Tank
**	483900	Decal, Warning Spark Arrestor (California Models Only - not shown)
**	01411	DVD Video, Tips for Safe Operation of Your Scag Zero-Turn Mower

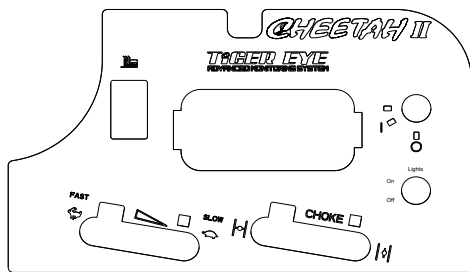

15

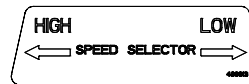

16



4

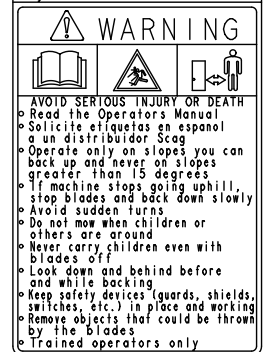
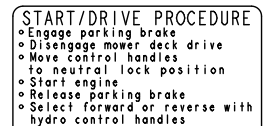

17

IMPORTANT ADJUSTMENT PROCEDURES
READ OPERATORS MANUAL FOR MORE DETAILS
Check tire pressure: SCZII-61/72 Drive tires-12 psi
Caster tires-Flat Free.

FREE WHEEL OPERATION
To move machine without running engine, turn valve on LH & RH transaxles from RUN to BY-PASS. (See operator's manual)

NEUTRAL ADJUSTMENT
ALIGN TABS

To re-set neutral, have engine off and control levers in neutral. Remove rear wheels. Adjust linkage turnbuckle until tabs on transaxle align. Repeat for opposite side. If wheels still creep after adjustment, see an authorized Scag dealer.

HYDRAULIC FLUID LEVEL
Check hydraulic fluid level while fluid is cool. Fluid level should be at full cold line on tanks. Fill with 20W50 motor oil only.

IMPORTANT
Do not overfill. Room for hot fluid expansion must be allowed or resulting expansion may cause leaks in the system.

TRACKING ADJUSTMENT
CONTROL LEVER
Stop Bolt

If machine pulls to right, adjust LH control stop bolt CW (Inward) to slow left wheel down.
If machine pulls to left, adjust RH control stop bolt CW (Inward) to slow right wheel down.

18



7

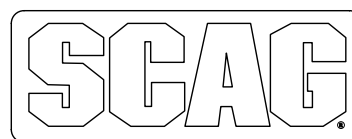

21

SCZII ELECTRICAL SCHEMATIC

(shown with Key Off, PTO Off, Park Brake Applied, Control Handles in Neutral, Seat Switch Disengaged)

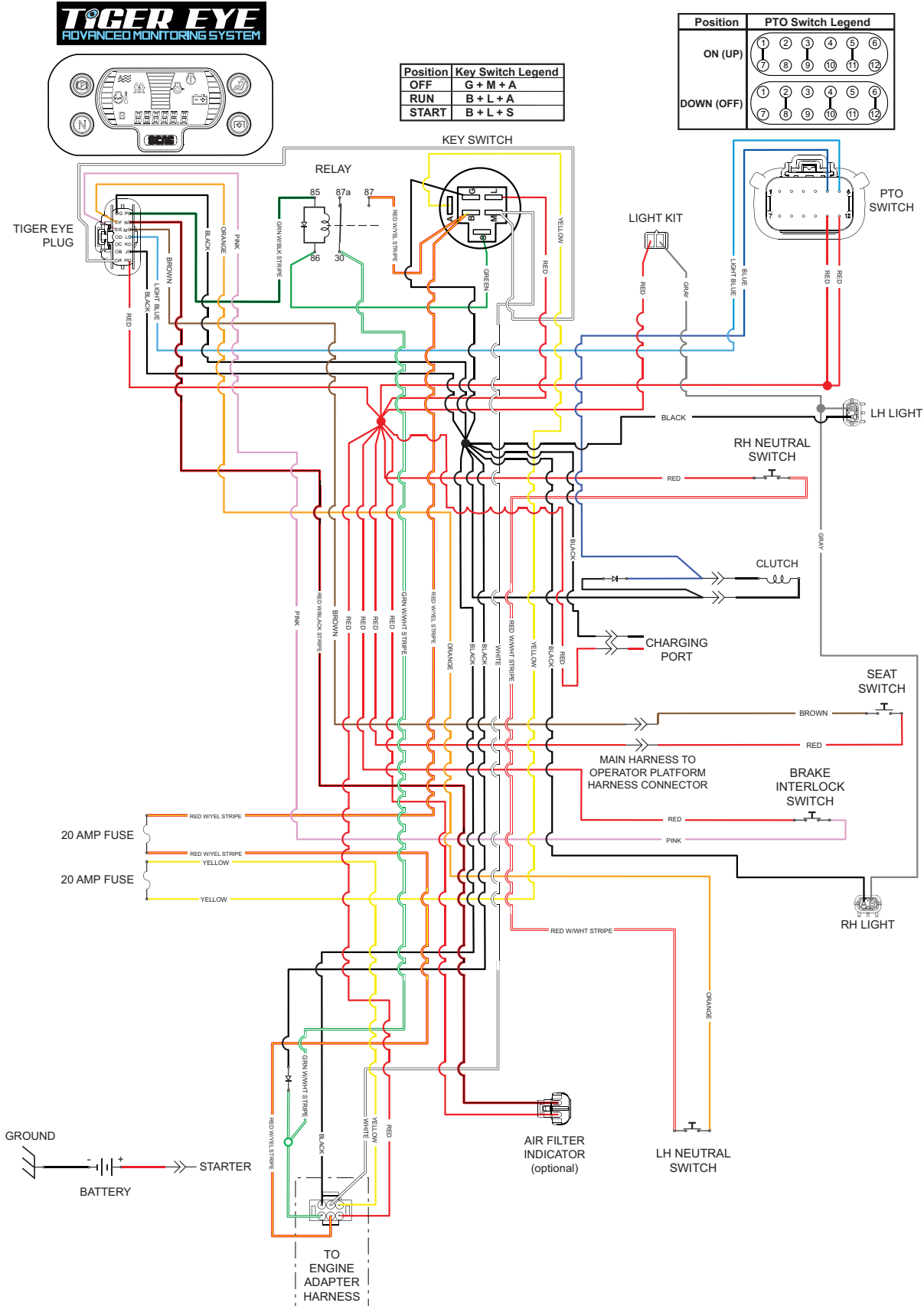

SCZII BV-EFI / CV-EFI ELECTRICAL SCHEMATIC

(shown with Key Off, PTO Off, Park Brake Applied, Control Handles in Neutral, Seat Switch Disengaged)

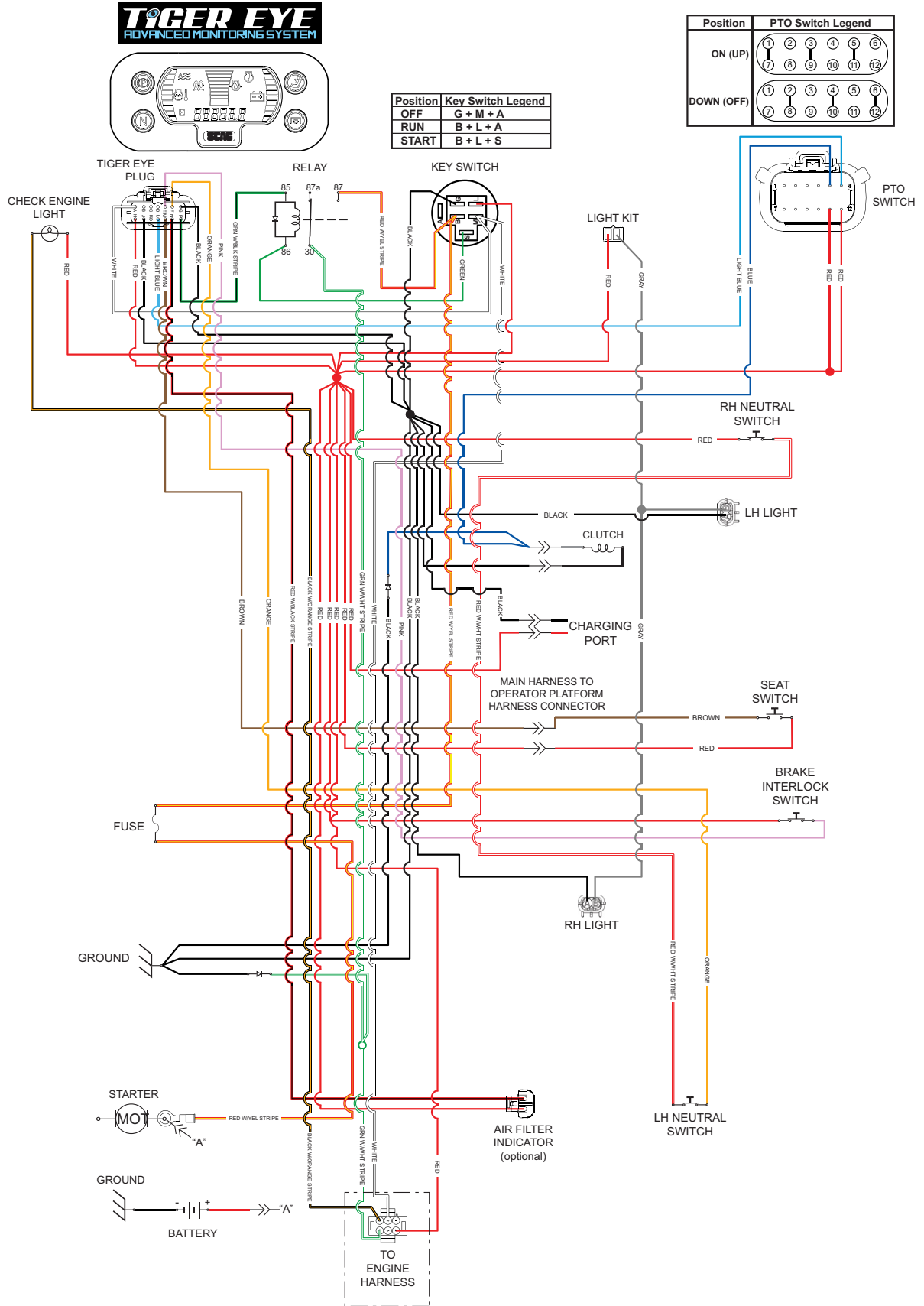

BRIGGS & STRATTON / KOHLER- EFI ADAPTER HARNESS ELECTRICAL SCHEMATIC

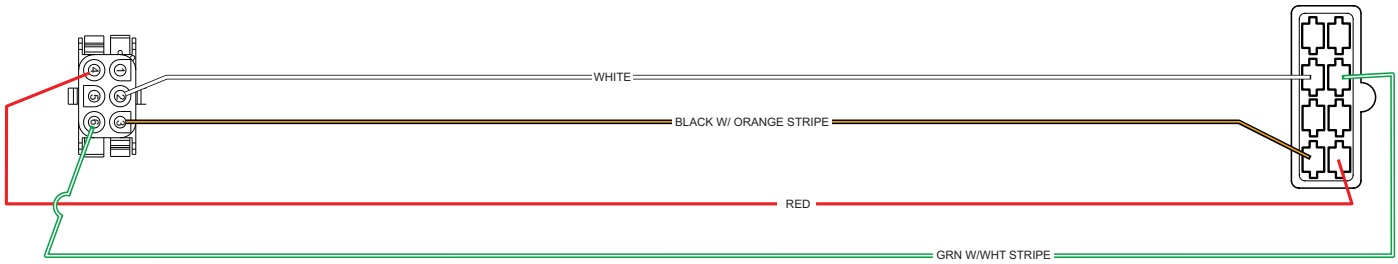

SCZII FX-EFI ELECTRICAL SCHEMATIC

(shown with Key Off, PTO Off, Park Brake Applied, Control Handles in Neutral, Seat Switch Disengaged)

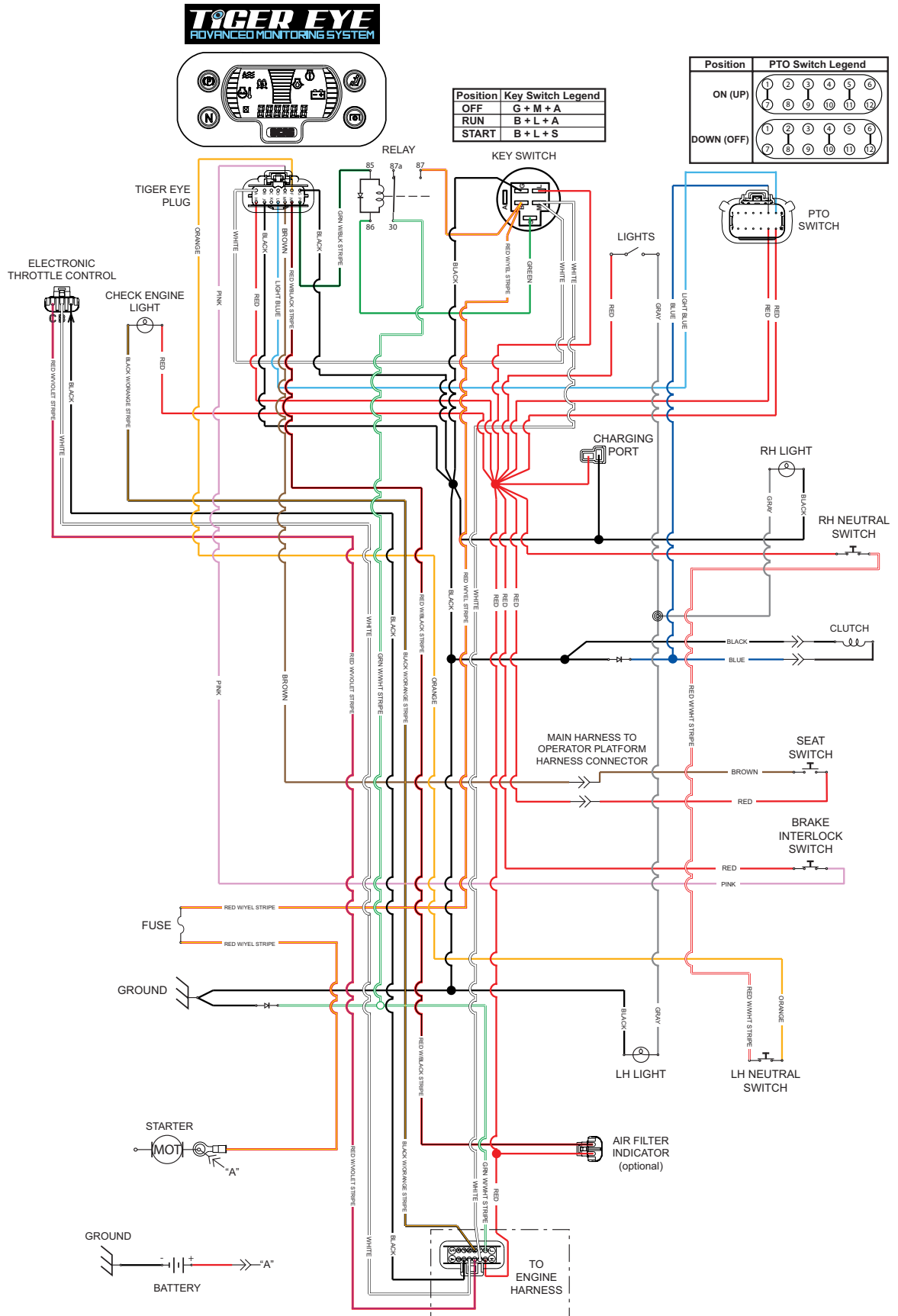

LIMITED WARRANTY - COMMERCIAL EQUIPMENT

Any part of the Scag commercial mower manufactured by Scag Power Equipment and found, in the reasonable judgment of Scag, to be defective in materials or workmanship, will be repaired or replaced by an Authorized Scag Service Dealer without charge for parts and labor during the periods specified below. This warranty is limited to the original purchaser provided the product was purchased from an Authorized Scag Power Equipment Dealer and is not transferable. Proof of purchase will be required by the dealer to substantiate any warranty claims. All warranty work must be performed by an Authorized Scag Service Dealer.

This warranty is limited to the following specified periods from the date of the original retail purchase for defects in materials or workmanship:

- Wear items including drive belts, blades, hydraulic hoses and tires are warranted for ninety (90) days.
- Batteries are covered for ninety (90) days.
- Frame and structural components including oil reservoir and oil coolers are warranted for two (2) years (parts and labor) for commercial use or three (3) years / 500 hours (whichever comes first) (parts and labor) for non-commercial use.
- Cutter decks are warranted against cracking for a period of three (3) years. (parts and labor 1st and 2nd year; parts only 3rd year.) The repair or replacement of the cutter deck will be at the option of Scag Power Equipment. We reserve the right to request components for evaluation. This warranty does not cover any mower that has been subject to misuse, neglect, negligence, or accident, or that has been operated in any way contrary to the operating instructions as specified in the Operator's Manual.
- Engines and electric starters are covered by the engine manufacturer's warranty period.
- Major drive system components are warranted for two (2) years (parts and labor) for commercial use or three (3) year / 500 hour (whichever comes first) (parts and labor) for non-commercial use by Scag Power Equipment. (commercial and non-commercial warranty excludes fittings, hoses, drive belts). The repair or replacement of the hydraulic pump or hydraulic motor will be at the option of Scag Power Equipment. This warranty does not cover any mower that has been subject to misuse, neglect, negligence, or accident, or that has been operated in any way contrary to the operating instructions as specified in the Operator's Manual.
- Electric clutches have a Limited Warranty for two (2) years (parts and labor) for commercial use or three (3) year / 500 hours (whichever comes first) (parts and labor) for non-commercial use.
- Spindle assemblies have a Limited Warranty for three years (parts and labor 1st year and 2nd; parts only 3rd year).
- Any Scag product used for rental purposes is covered by a 90 day warranty.

The Scag mower, including any defective part must be returned to an Authorized Scag Service Dealer within the warranty period. The expense of delivering the mower to the dealer for warranty work and the expense of returning it to the owner after repair will be paid for by the owner. Scag's responsibility is limited to making the required repairs and no claim of breach of warranty shall be cause for cancellation or rescission of the contract of sale of any Scag mower. "Non-Commercial" use is defined as a single property owner, where the single property is the residence of the owner of the mower. If the mower is cutting more than the owners single property, it is deemed commercial use and the "non-commercial" warranty does not apply. Scag Power Equipment reserves the right to deny and / or void the non-commercial warranty if it believes it to be in commercial use.

This warranty does not cover any mower that has been subject to misuse, neglect, negligence, or accident, or that has been operated in any way contrary to the operating instructions as specified in the Operator's Manual. The warranty does not apply to any damage to the mower that is the result of improper maintenance, or to any mower or parts that have not been assembled or installed as specified in the Operator's Manual and Assembly Manual. The warranty does not cover any mower that has been altered or modified, changing performance or durability. In addition, the warranty does not extend to repairs made necessary by normal wear, or by the use of parts or accessories which, in the reasonable judgment of Scag, are either incompatible with the Scag mower or adversely affect its operation, performance or durability.

Scag Power Equipment reserves the right to change or improve the design of any mower without assuming any obligation to modify any mower previously manufactured. All other implied warranties are limited in duration to the two (2) year for commercial use, three (3) years / 500 hour for non-commercial use or ninety (90) days for mowers used for rental purpose. Accordingly, any such implied warranties including merchantability, fitness for a particular purpose, or otherwise, are disclaimed in their entirety after the expiration of the appropriate two year, three year / 500 hour or ninety day warranty period. Scag's obligation under this warranty is strictly and exclusively limited to the repair or replacement of defective parts and Scag does not assume or authorize anyone to assume for them any other obligation. Some states do not allow limitations on how long an implied warranty lasts, so the above limitation may not apply to you.

Scag assumes no responsibility for incidental, consequential or other damages including, but not limited to, expense for gasoline, expense of delivering the mower to an Authorized Scag Service Dealer and expense of returning it to the owner, mechanic's travel time, telephone or telegram charges, rental of a like product during the time warranty repairs are being performed, travel, loss or damage to personal property, loss of revenue, loss of use of the mower, loss of time or inconvenience. Some states do not allow the exclusion or limitation of incidental or consequential damages, so the above limitation or exclusion may not apply to you. This warranty gives you specific legal rights, and you may also have other rights which vary from state to state.

