

*Parts Manual for*  
**GIANT-VAC<sup>®</sup>**

**FIELD & BRUSH MOWER  
SERIES 0**



**MODEL**

**FB13250BS (7085922)**

**GM2513BS (3070980)**

**GM2513H (3070101)**

**GM2513H (7085924)**

**GM2515KAW (3070103)**

**GM2515KAW (7085923)**

**GM2516BVG (3800017)**

**GIANT-VAC<sup>®</sup>**



<b>PAGE</b>	<b>GROUP</b>
4	HANDLE PARTS GROUP
8	ENGINE DECK GROUP
12	MOWER DECK PARTS GROUP
14	DECALS GROUP
16	ELECTRICAL & MISC. GROUP
18	WIRING HARNESS GROUP
20	WIRING SCHEMATIC
22	Hardware Identification & Torque Specifications

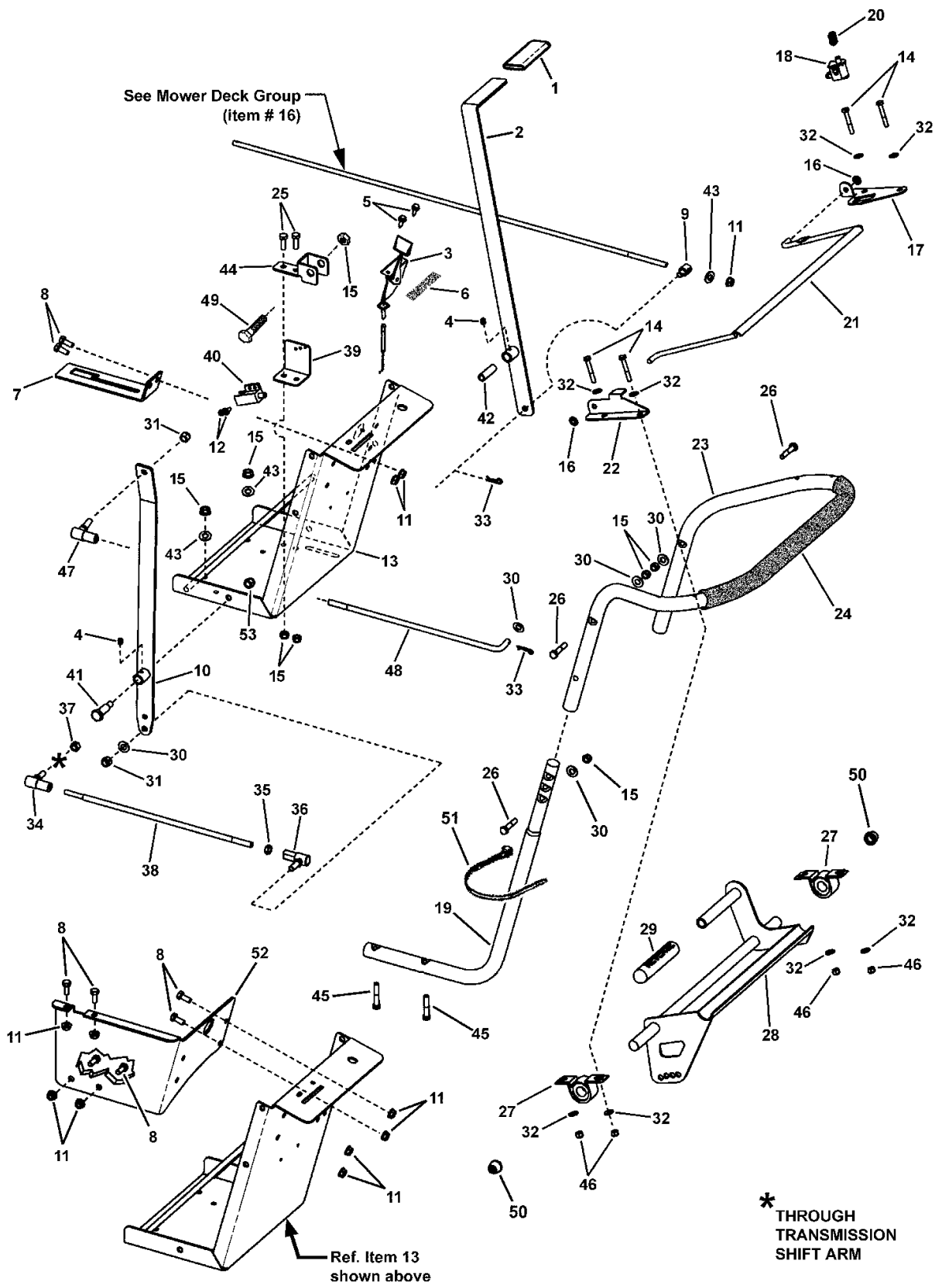

## HANDLE PARTS GROUP

Item	Part No	Qty	Description	Note
1	1719965	1	GRIP, Handle	
2	7058960	1	LEVER, Blade Clutch Engage (weldment)	
3	7027394	1	THROTTLE CONTROL, Briggs 23"	<i>part number stamped on cable</i>
3	7027802	1	THROTTLE CONTROL, Kawasaki 38"	<i>part number stamped on cable</i>
3	1723686	1	THROTTLE CONTROL, Honda 34.6"	<i>part number stamped on cable</i>
4	7014871	2	LUBE FITTING, 3/16" hole	<i>or 7013864</i>
5	7090290	2	SCREW, 1/4-20 x 3/4" Hex Washer Self-Tap	<i>or 7091686</i>
6	7029167	1	DECAL, Throttle, Brush Cutter	<i>see Decals group</i>
7	1723550	1	BRACKET, Blade Engage Lock	
8	7091318	2	SCREW, 5/16-18 x 3/4" Hex Head Cap, GR 5	
9	7028200	1	SWIVEL, Adjustable, 5/16-18 thread	
10	7059204	1	LEVER, Transmission Drive (weldment)	
11	7091601	6	NUT, 5/16-18 Hex Flange Lock, GR 5	
12	7090913	2	SCREW, #10C x 1/2" Hex Head Self-Tap (Torx)	
13	1723553	1	CONTROL DECK & DASH PANEL (weldment)	
14	7091813	4	SCREW, 1/4-20 x 1-3/4" Hex Head Cap, GR 5	
15	7091298	11	NUT 5/16-18 Hex Nyloc	
16	7011791	3	RETAINER, 5/16" Bolt	
17	7072487	1	BRACKET, Handle Pivot, RH	
18	7023354	1	SWITCH, OPC, NC	
19	1723569	2	HANDLE, Lower	
20	1723564	1	SPRING, Safety Return	
21	1723561	1	WELDMENT, Safety Bar	
22	7044927	1	BRACKET, Safety Bar Pivot, LH	
23	7033736	1	HANDLE, Upper	<i>or 1723572</i>
24	1723568	1	COVER, Foam	
25	7090209	6	SCREW, 5/16-18 x 1" Hex Head Cap, GR 2	
26	7091540	4	SCREW, 5/16-18 x 1-1/2" Hex Head Cap, GR 5	
27	1723570	2	BEARING, 3/4 I.D.	
28	1725232	1	WELDMENT, Drive Engagement Bar	
29	1725233	1	GRIP, Reverse Handle	
30	7090122	1	WASHER, 3/8 SAE Flat	
31	7091518	2	NUT, 3/8-24 Hex Nyloc	
32	7091294	8	WASHER, .28 x .63 x .06 Flat	
33	7091310	2	HAIR PIN, #13	
34	1723554	1	BALL JOINT, Type R (5/16-24 thread)	
35	1723556	1	NUT, 3/8-24LH Hex Jam	
36	1723557	1	BALL JOINT LH (3/8-24 LH thread)	
37	7092031	1	NUT, 5/16-24 Hex Jam	
38	1723555	1	ROD, Trans. Engage, Lower (3/8-24 & 5/16-24 threads)	

### Footnotes:

# HANDLE PARTS GROUP

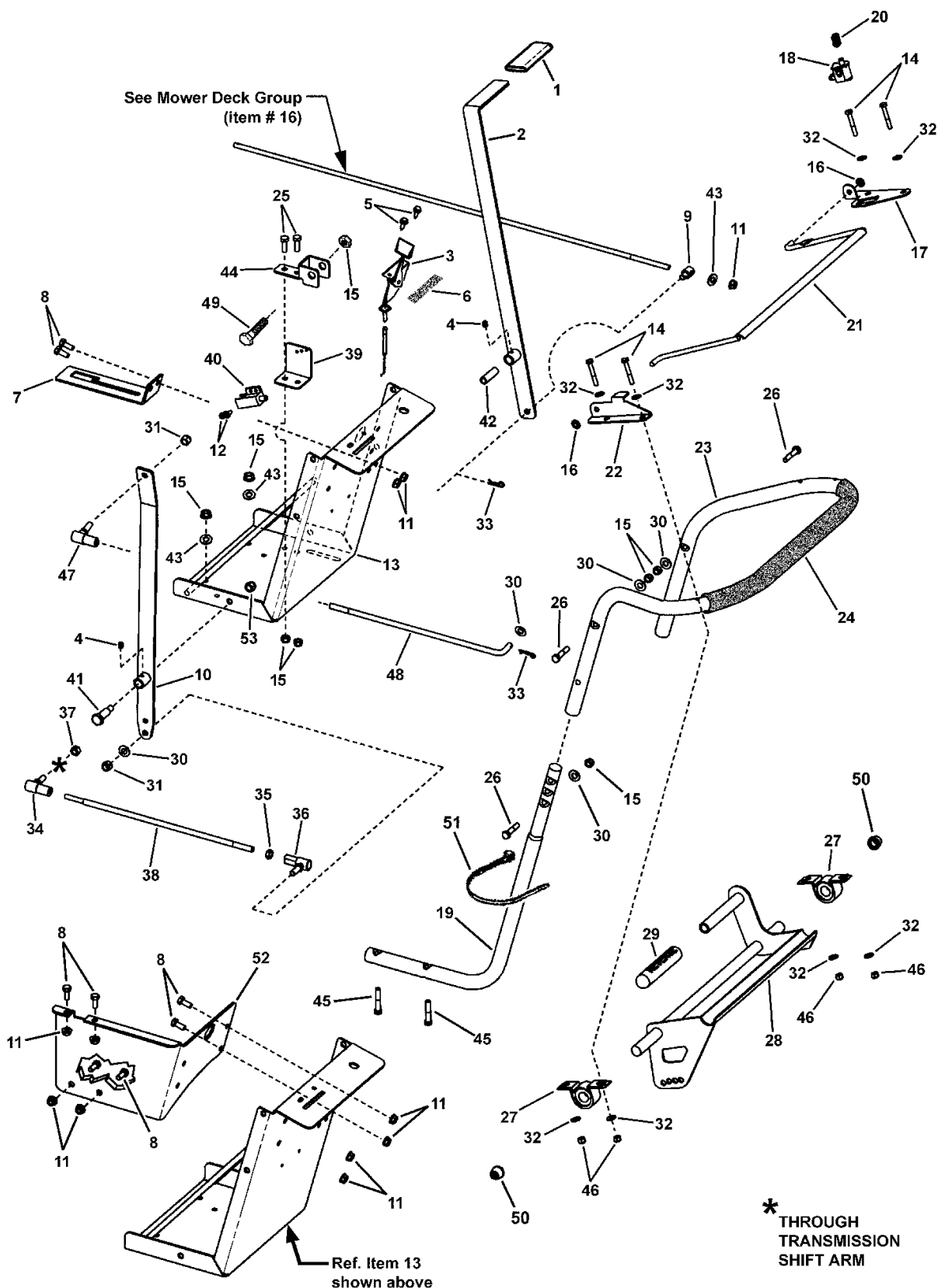

## **HANDLE PARTS GROUP**

---

<b>Item</b>	<b>Part No</b>	<b>Qty</b>	<b>Description</b>	<b>Note</b>
39	1723351	1	BRACKET, Deck Safety Switch	
40	1723552	1	SWITCH, Deck Safety	
41	1723662	1	BOLT, 1/2 x 1-3/16 to 3/8-16 Shoulder	
42	7041868	1	SPACER, Transmission, Express	
43	7090188	2	WASHER, 5/16" SAE Flat	
44	1723596	1	BRACKET, Clutch Engage Lever	
45	7091908	8	SCREW, 5/16-18 x 1-3/4" Hex Head Cap, GR 5	
46	7091603	4	NUT, 1/4-20 Hex Nyloc	
47	7010745	1	BALL JOINT, 3/8-24 Thread	
48	1725231	1	ROD, Trans. Engage, Upper (3/8-24 thread)	
49	7076938	4	SCREW, 5/16-18 x 2-1/4" Hex Head Cap, GR 5	
50	7029495	2	CAP, Push Plastic (for 3/4" dia. Rod)	
51	7012080	2	CABLE TIE, 7"	
52	1723616	1	BRACKET, Fuel Tank	
53	7091619	1	NUT, 3/8-16 Hex Flange Lock	

### **Footnotes:**

# ENGINE DECK GROUP

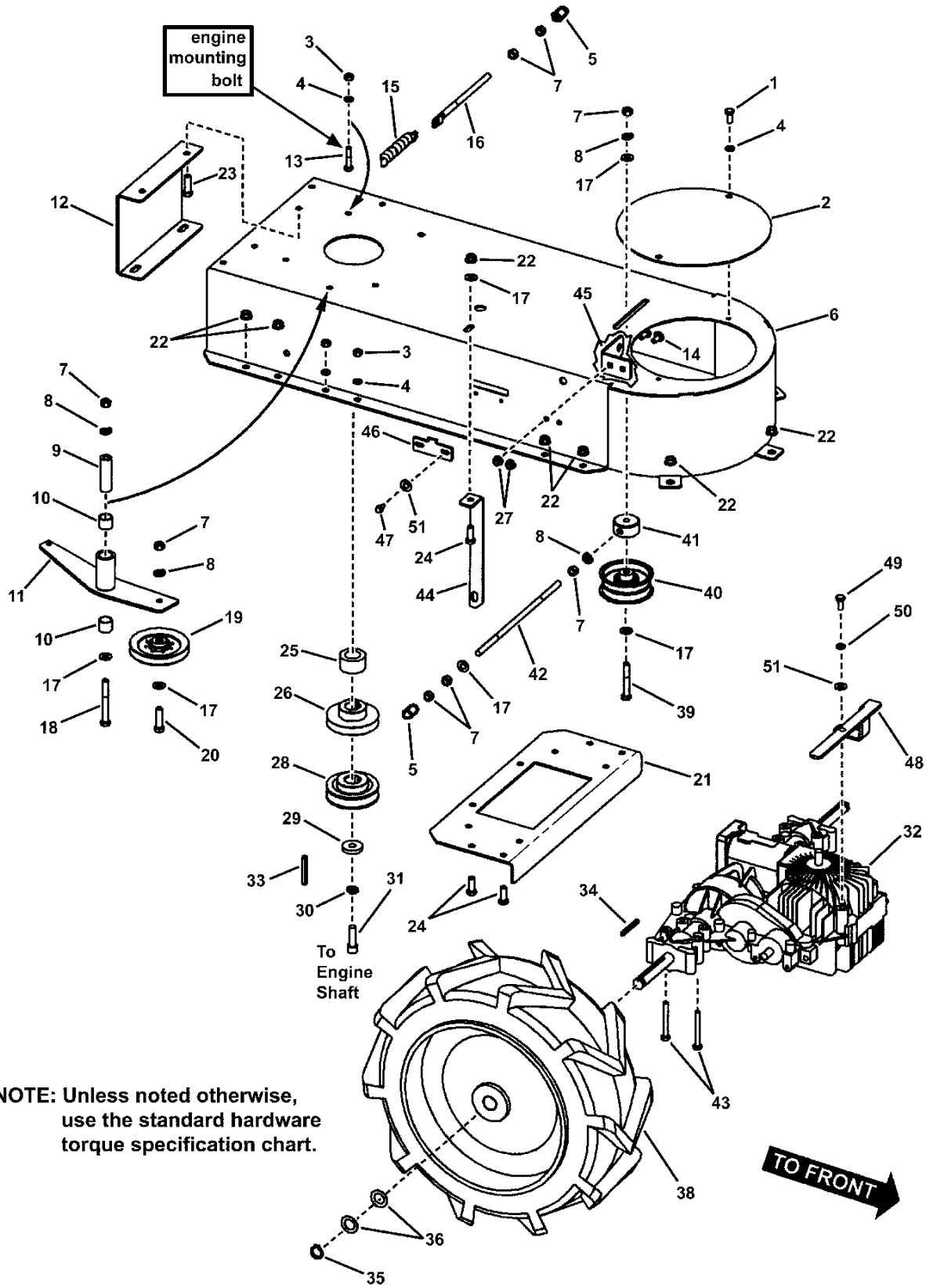



## ENGINE DECK GROUP

Item	Part No	Qty	Description	Note
1	7091318	10	SCREW, 5/16-18 x 3/4" Hex Head Cap, GR 5	
2	1723549	1	PLATE, Clutch Cover	
3	7091511	3	NUT, 5/16-18 Hex, GR 5 or B	
4	7090187	18	WASHER, 5/16" Split Lock	
5	1704723	2	CAP, Black	
6	1723803	1	DECK, Engine (weldment)	
7	7091302	24	NUT, 3/8-16 Hex, GR 5 or B	
8	7091320	22	WASHER, .38 x .68 x .09 Split Lock	
9	1723806	1	BOSS, Idler Arm Pivot	
10	1723805	2	SLEEVE BUSHING, 3/4 ID	
11	1723804	1	IDLER ARM, Transmission (weldment)	
12	1723592	1	COVER, Engine Back	
13	7091540	4	SCREW, 5/16-18 x 1-1/2" Hex Head Cap, GR 5	
14	7091508	2	BOLT, 5/16-18 x 3/4" Short Neck Carriage, GR 5	or 7090001
15	1723807	1	SPRING, Idler	
16	1723808	1	ROD, Idler Tension (3/8-16 thread)	
17	7090122	9	WASHER, 3/8 SAE Flat	
18	7092055	1	SCREW, 3/8-16 x 3-1/4" Hex Head Cap	
19	1723583	1	PULLEY, Idler	
20	7091553	1	SCREW, 3/8-16 x 1-3/4" Hex Head Cap, GR 5	
21	1723591	1	PLATE, Lower Handle Mount	
22	7091619	12	NUT, 3/8-16 Hex Flange Lock	or 7090613
23	7091328	2	SCREW, 3/8-16 x 1-1/4" Hex Head Cap, GR 5	
24	7091304	7	SCREW, 3/8-16 x 1 Hex Head Cap, GR 5	
25	1723585	1	SPACER, Engine Shaft	
26	1723586	1	PULLEY, Blade Clutch Drive	
27	7091601	2	NUT, 5/16-18 Hex Flange Lock, GR 5	
28	1723588	1	PULLEY, Trans. Drive	
29	7091807	1	WASHER, .468 x 1-3/8 x 1/4" Flat	
30	7091301	1	WASHER, 7/16" Split Lock	
31	1723589	1	CAPSCREW, 7/16-20 x 1-12" Socket Head	
32	1723620	1	TRANSAXLE	
33	1723590	1	KEY, 1/4 Square x 2-1/8" (engine shaft)	(engine shaft)
34	7072386	2	KEY, 3/16 Square x 2-3/16"	
35	7010746	2	RETAINING RING, 3/4" External	Waldes 5160-75
36	7031965	4	WASHER, 3/4 I.D. Thrust	
37	1723580	1	DRIVE WHEEL, Left	not shown
38	1723581	1	DRIVE WHEEL, Right	
39	7091501	1	SCREW, 3/8-16 x 2-1/2" Hex Head Cap, GR 5	
40	1723579	1	PULLEY, Blade Clutch Idler	

### Footnotes:

Note: \* Purchase engine & engine parts other than those listed from engine service outlets.

**ENGINE DECK GROUP**

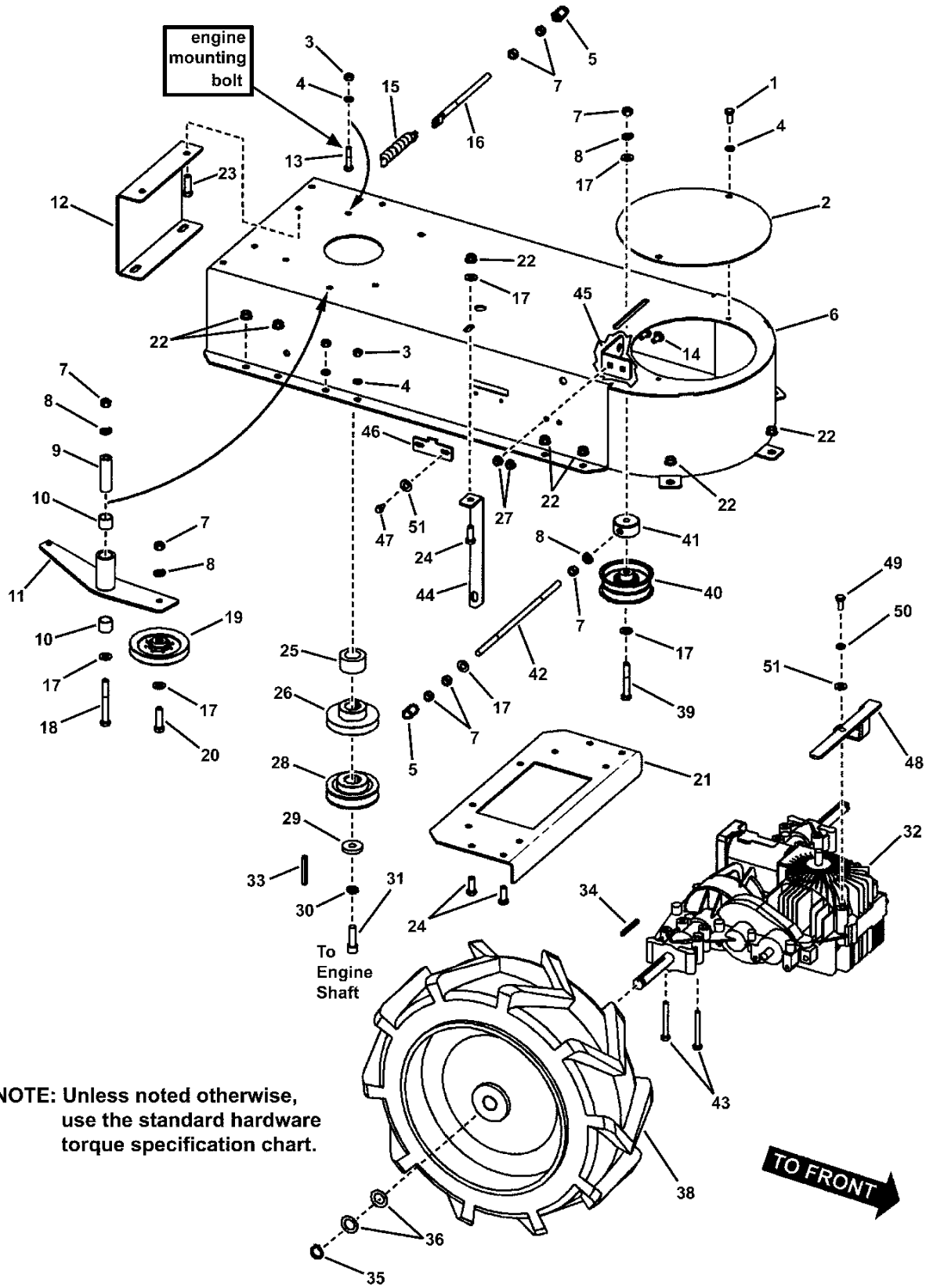

## ENGINE DECK GROUP

---

Item	Part No	Qty	Description	Note
41	1723577	1	IDLER BOSS	
42	1723576	1	ROD, Blade Clutch Idler Tensioning (3/8-16 thread)	
43	7076938	4	SCREW, 5/16-18 x 2-1/4" Hex Head Cap, GR 5	
44	1723575	1	HANGER, Trans. Forward Mount	
45	7072520	1	BRACKET, Clutch Support	
46	1723622	1	PLATE, Lock Engage	
47	7090290	2	SCREW, 1/4-20 x 3/4" Hex Washer Self-Tap	or 7091686
48	1723621	1	BRACKET, Lock Lever (weldment)	
49	7091536	1	SCREW, 1/4-28 x 5/8" Hex Head Cap, GR 8	
50	7090052	1	WASHER, 1/4" Split Lock	
51	7091294	3	WASHER, .28 x .63 x .06 Flat	
	7072515	1	BRACKET, Fuel Tank Bottom (not shown)	Briggs part# 225903
	21B977-0120	1	* ENGINE, Briggs 13.5HP Elect. Start	
	305777-0133		* ENGINE, Briggs 16HP Elect. Start	
	GXV390K1D	1	* ENGINE, Honda 13HP	
	FH451V-AS0	1	* ENGINE, Kawasaki 15HP	

### Footnotes:

Note: \* Purchase engine & engine parts other than those listed from engine service outlets.

# MOWER DECK PARTS GROUP

NOTE: Unless noted otherwise, use the standard hardware torque specification chart.

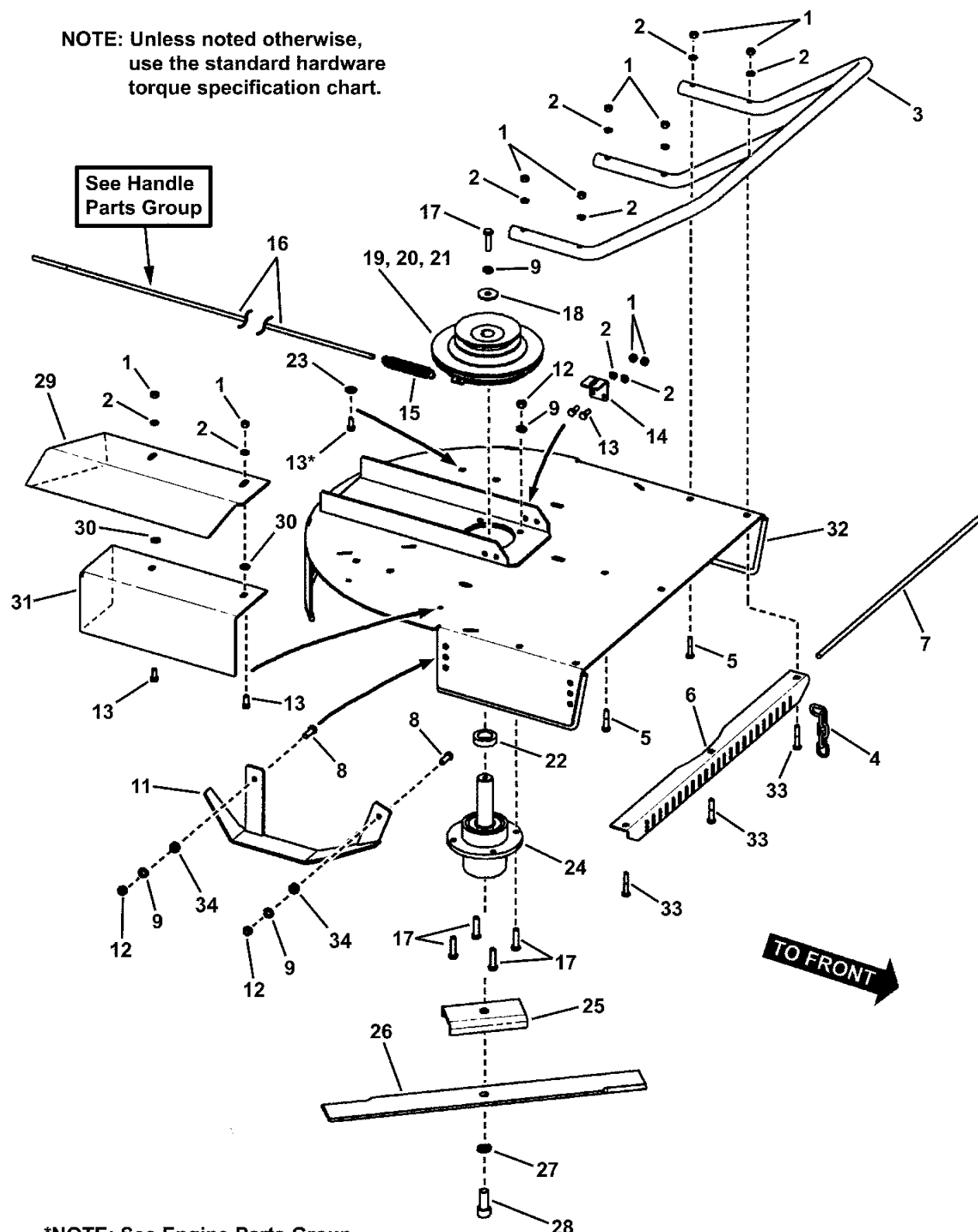

\*NOTE: See Engine Parts Group

Torque to 233 ft. lbs. (315 N. m.)

## MOWER DECK PARTS GROUP

Item	Part No	Qty	Description	Note
1	7091511	8	NUT, 5/16-18 Hex, GR 5 or B	
2	7090187	8	WASHER, 5/16" Split Lock	
3	1723532	1	WELDMENT, Front Bumper	
4	1723533	23	CHAIN CURTAIN	
5	7091540	3	SCREW, 5/16-18 x 1-1/2" Hex Head Cap, GR 5	<i>for bumper rear holes</i>
6	1723534	1	BRACKET, Chain Curtain	
7	1723535	1	ROD, Chain Curtain Mounting	
8	7091304	4	SCREW, 3/8-16 x 1 Hex Head Cap, GR 5	
9	7091320	9	WASHER, .38 x .68 x .09 Split Lock	
10	1723536	1	LEFT SKID, Blade Deck (weldment)	<i>not shown</i>
11	1723537	1	RIGHT SKID, Blade Deck (weldment)	
12	7091302	4	NUT, 3/8-16 Hex, GR 5 or B	
13	7091318	2	SCREW, 5/16-18 x 3/4" Hex Head Cap, GR 5	
14	1723538	1	BRACKET, Anti-Torque	
15	1723657	1	SPRING, Clutch	
16	1723539	1	ROD, Blade Clutch Engagement (5/16-18 threaded)	
17	7091497	5	SCREW, 3/8-16 x 1-1/2" Hex Head Cap, GR 5	
18	3031409	1	WASHER, 7/16 I.D. x 1-1/2" Flat (Heavy Duty)	<i>this fastener furnished w/clutch (Noram part no. CB84S)</i>
19	1723540	1	ASSEMBLY, Clutch Brake	
20	7090209	1	SCREW, 5/16-18 x 1" Hex Head Cap	<i>this fastener furnished w/clutch</i>
21	7091298	1	NUT, 5/16-18 Hex Center Lock	<i>this fastener furnished w/clutch</i>
22	1723541	1	SPACER, Clutch	
23	7090122	3	WASHER, 3/8 SAE Flat	
24	1723542	1	ASSEMBLY, Blade Spindle	
25	1723543	1	CHANNEL, Cutting Blade Reinforcement	
26	1723544	1	CUTTING BLADE	
27	7090333	1	WASHER, 5/8" Split Lock	
28	1725227	1	CAPSCREW, 5/8-11 x 1-1/2" Socket	
29	1723546	1	DELFECTOR, Discharge (weldment)	
30	7090188	2	WASHER, 5/16" SAE Flat	
31	1723547	1	COVER, Discharge (weldment)	
32	1723548	1	BLADE DECK	
33	7091908	3	SCREW, 5/16-18 x 1-3/4 Hex Head Cap, GR 5	<i>for bumper front holes</i>
34	7028620	4	SPACER, .340 I.D. x .630 O.D. x .310 thick	

### Footnotes:

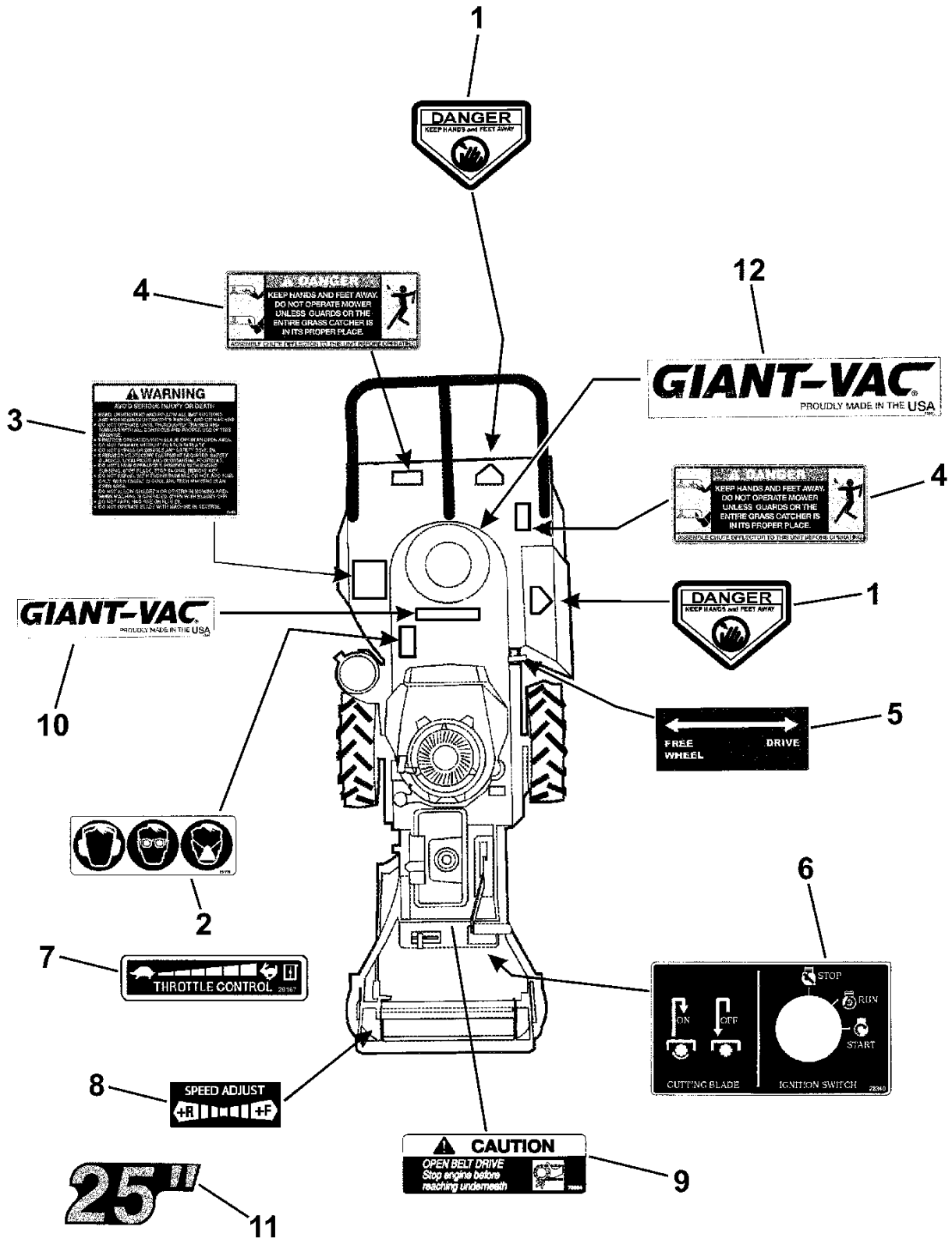

## **DECALS GROUP**

---

<b>Item</b>	<b>Part No</b>	<b>Qty</b>	<b>Description</b>	<b>Note</b>
1	7013010	2	DECAL, Danger, Cut Finger (CPSC)	
2	7075893	1	DECAL, Personal Protection	
3	7028490	1	DECAL, Warning, Brush Cutter	
4	7073647	2	DECAL, Caution, Guard Catcher	
5	1725229	1	DECAL, Transmission Drive	
6	7028349	1	DECAL, Ignition/Cutting Blade	
7	7029167	1	DECAL, Throttle, Brush Cutter	
8	1725230	1	DECAL, Speed Adjuster	
9	7073594	1	DECAL, Caution, Open Belt Drive	
10	7029445	1	DECAL, Giant-Vac (9-3/16" long)	
11	7029331	1	DECAL, 25"	
12	7075861	1	DECAL, Giant-Vac (12-1/2" long)	

**Footnotes:**

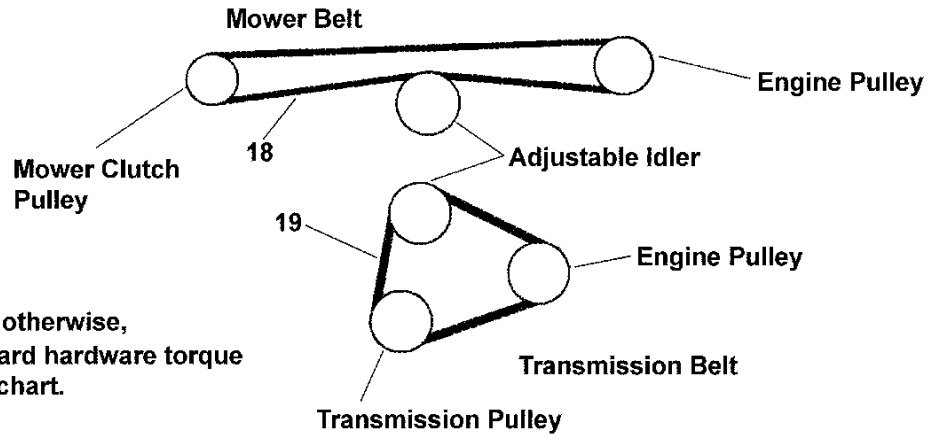
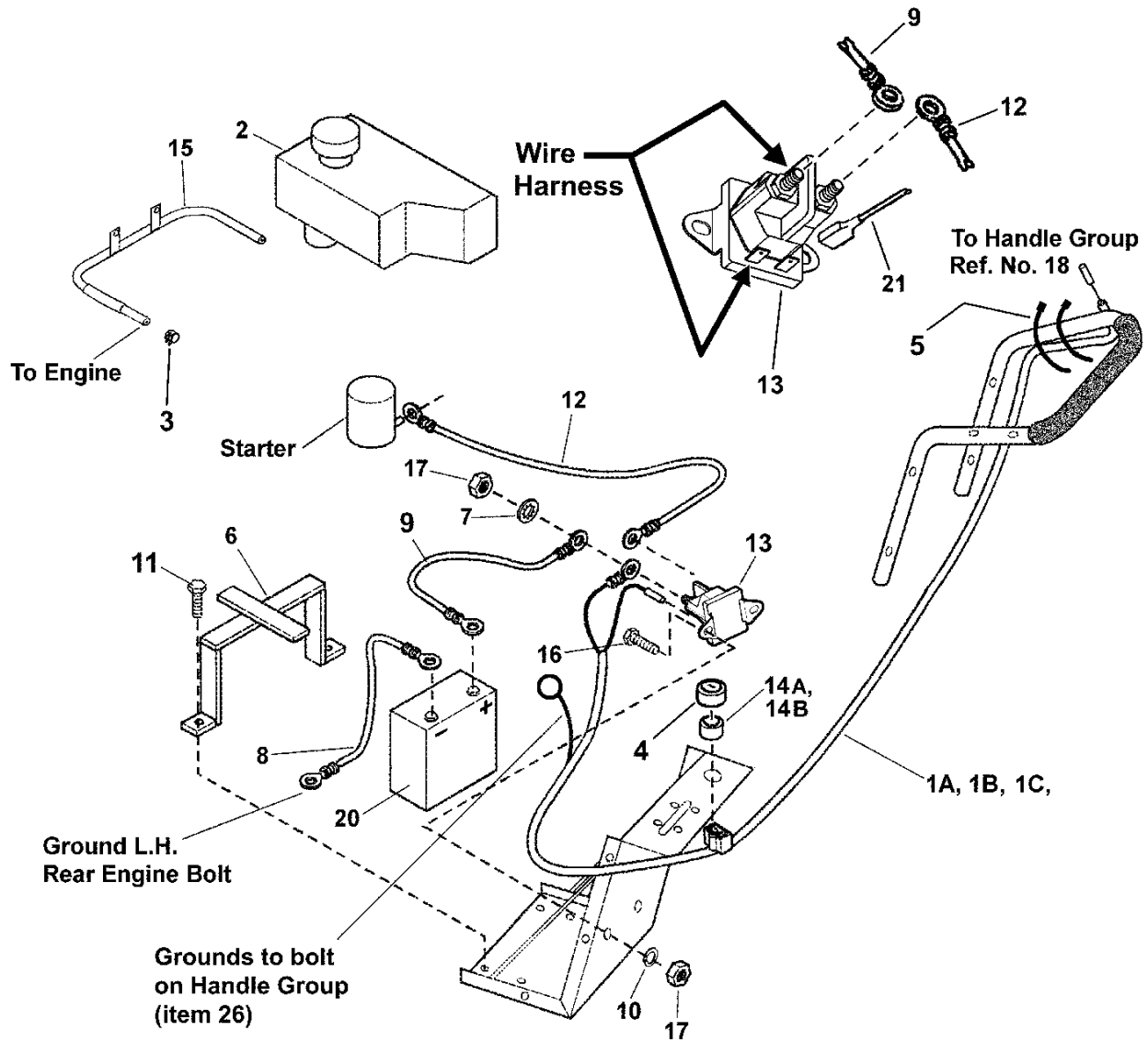

**NOTE:** Unless noted otherwise, use the standard hardware torque specification chart.



## ELECTRICAL & MISC. GROUP

Item	Part No	Qty	Description	Note
1A	7044922	1	WIRE HARNESS, Briggs	
1B	7044926	1	WIRE HARNESS, Kawasaki	
1C	1723632	1	WIRING HARNESS, Honda	
2	1723618	1	FUEL TANK, Auxilliary	
3	7029900	2	CLAMP, Fuel Hose	
4	7023506	1	BEZEL	
5	7012080	2	CABLE TIE, 7"	
6	1723635	1	BRACKET, Battery Hold Down	
7	7090053	2	WASHER, 1/4" Internal Tooth Lock	<i>or 7091314</i>
8	1725226	1	CABLE, Battery Negative to Ground	<i>not used on Honda model</i>
9	1723637	1	CABLE, Battery Positive to Solenoid	<i>not used on Honda model</i>
10	7090052	3	WASHER, 1/4 Split Lock	
11	1723636	1	SCREW, Tek #12 x 3/4" Hex Head Cap	
12	1723639	1	CABLE, Solenoid to Starter	
13	7075622	1	SOLENOID, Super Trombetta - 2 Terminal	<i>GV3031730</i>
14A	1723631	1	SWITCH, Keyed Start	<i>used in B&amp;S &amp; Kawasaki models</i>
14B	7017817	1	SWITCH, Ignition, 2-Pole	<i>used in Honda model</i>
15	1723619	1	FUEL LINE w/Clamps, 15HP Kaw & 16HP B&S (use 7072545)	<i>used on 13.5hp B&amp;S &amp; 15hp Kaw.</i>
15	1723685	1	FUEL LINE w/Clamps, 13HP Honda	
15	7029335	1	FUEL HOSE, 1/4" I.D. x 9" long	<i>used on Honda model only; not shown</i>
15	7072545	1	FUEL HOSE, 1/4" I.D. x 18" long	<i>not shown</i>
16	7091495	2	SCREW, 1/4-20 x 3/4" Hex Head Cap, GR 5	
17	7091576	2	NUT, 1/4-20 Hex, GR 5 or B	
18	1723629	1	BELT, Blade Clutch (5L Sect.; 67.40 effective length)	
19	1723630	1	BELT, Transmission (AX Sect.; 30.10 effective length)	
20	7029130	1	BATTERY, 12V, 3 Amp, 190 Cold Cranking Amp (Includes Drain Tube)	
21	7029332	1	GROUND WIRE, 16 Ga., Green, 19" long	
22	7029491	1	GROUND WIRE, Honda 5" (No longer available)	<i>not shown; grounds one terminal of key switch- Honda only)</i>

### Footnotes:

**BRIGGS (7044922)**

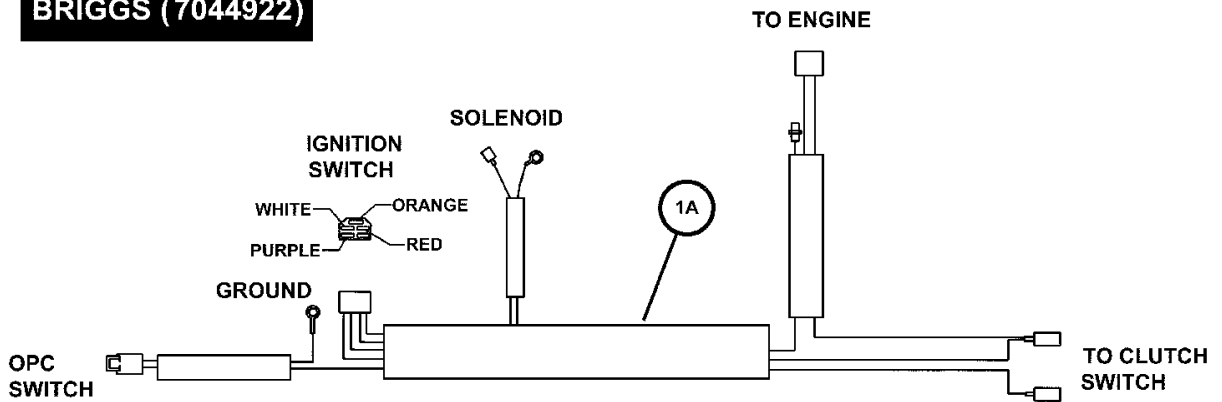

**KAWASAKI (7044926)**

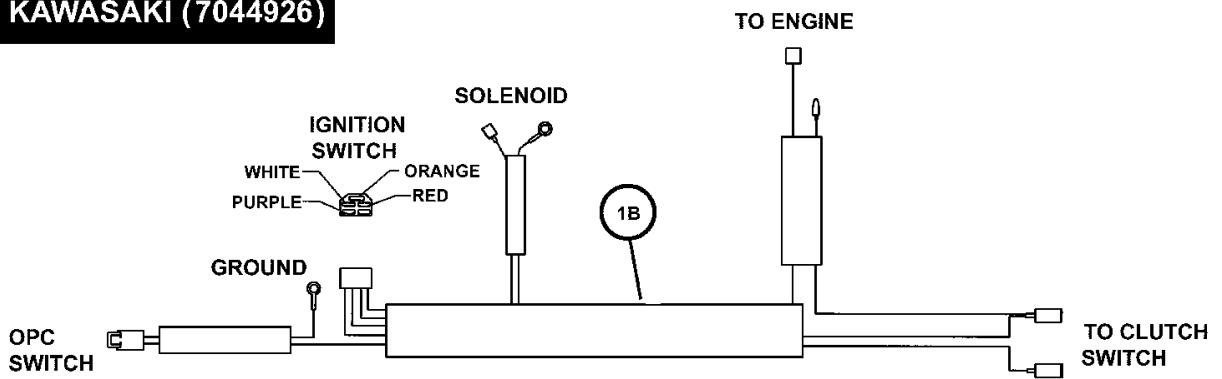

**HONDA (1723632)**

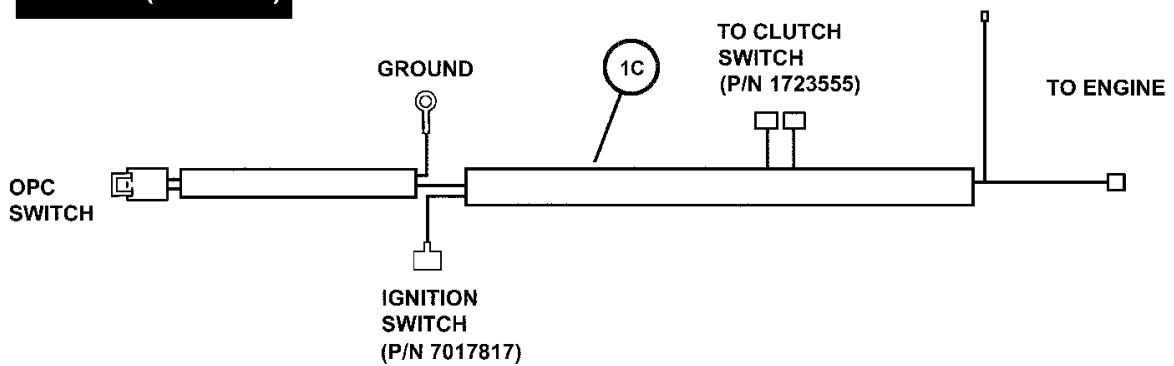

## **WIRING HARNESS GROUP**

---

<b>Item</b>	<b>Part No</b>	<b>Qty</b>	<b>Description</b>	<b>Note</b>
1A	7044922	1	WIRE HARNESS, Briggs	
1B	7044926	1	WIRE HARNESS, Kawasaki	
1C	1723632	1	WIRING HARNESS, Honda	

**Footnotes:**

**WIRING SCHEMATIC**

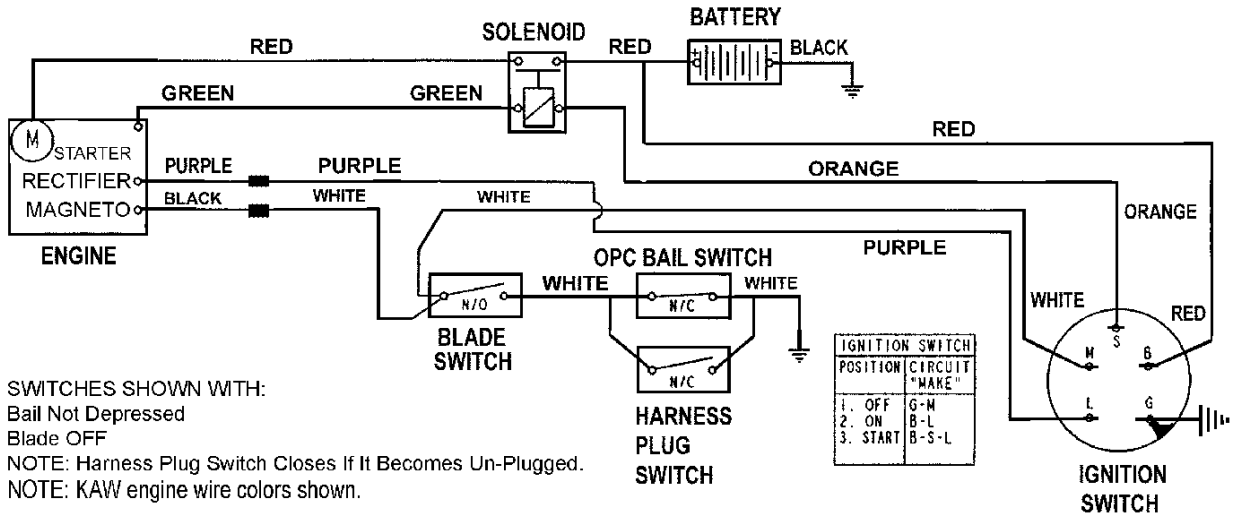

**Wiring Schematic for GM2513BS (Briggs) model with Harness # 7044922 and for GM2515KAW (Kawasaki) model with Harness # 7044926**

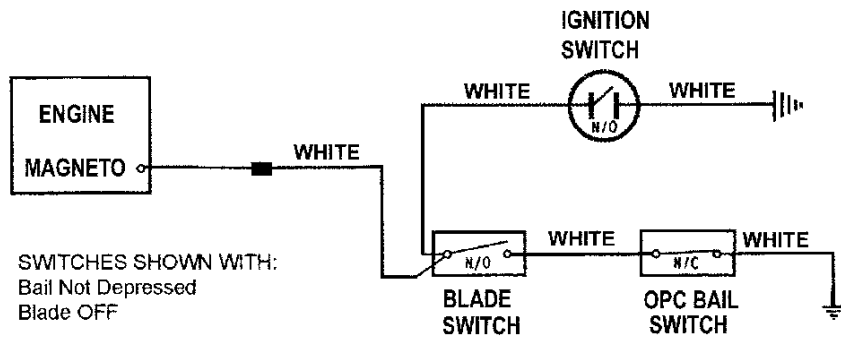

**Wiring Schematic for GM2513H (Honda) model with Harness # 1723632**

## **WIRING SCHEMATIC**

---

<b>Item</b>	<b>Part No</b>	<b>Qty</b>	<b>Description</b>	<b>Note</b>
		1	Wiring Schematic includes 3 harnesses	*7044922, 7044926 & 1723632

**Footnotes:**

# Hardware Identification & Torque Specifications

## Common Hardware Types

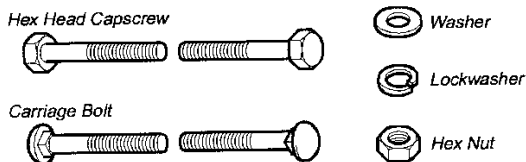

## Standard Hardware Sizing

When a washer or nut is identified as 1/2", this is the *Nominal size*, meaning the *inside diameter* is 1/2 inch; if a second number is present it represent the *threads per inch*

When bolt or capscrew is identified as 1/2 - 16 x 2", this means the *Nominal size*, or *body diameter* is 1/2 inch; the second number represents the *threads per inch* (16 in this example, and the final number is the *body length* of the bolt or screw (in this example 2 inches long).

*The guides and ruler furnished below are designed to help you select the appropriate hardware and tools.*

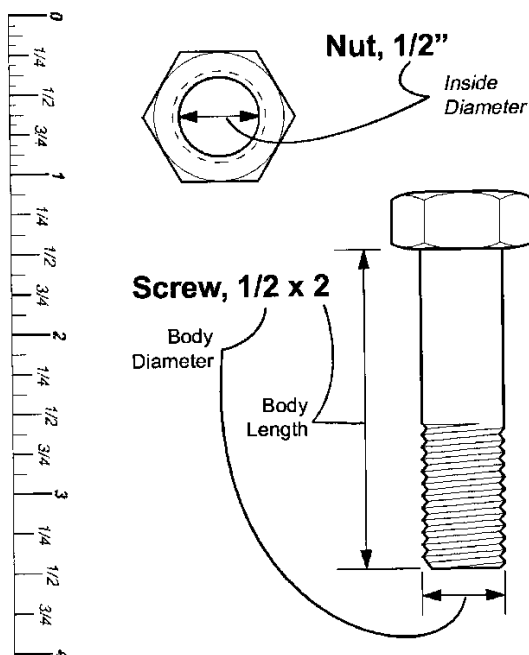

Torque Specification Chart						
FOR STANDARD MACHINE HARDWARE (Tolerance ± 20%)						
Hardware Grade	No Marks SAE Grade 2		SAE Grade 5		SAE Grade 8	
	in/lbs ft/lbs	Nm.	in/lbs ft/lbs	Nm.	in/lbs ft/lbs	Nm.
8-32	19	2.1	30	3.4	41	4.6
8-36	20	2.3	31	3.5	43	4.9
10-24	27	3.1	43	4.9	60	6.8
10-32	31	3.5	49	5.5	68	7.7
1/4-20	66	7.6	8	10.9	12	16.3
1/4-28	76	8.6	10	13.6	14	19.0
5/16-18	11	15.0	17	23.1	25	34.0
5/16-24	12	16.3	19	25.8	27	34.0
3/8-16	20	27.2	30	40.8	45	61.2
3/8-24	23	31.3	35	47.6	50	68.0
7/16-14	30	40.8	50	68.0	70	95.2
7/16-20	35	47.6	55	74.8	80	108.8
1/2-13	50	68.0	75	102.0	110	149.6
1/2-20	55	74.8	90	122.4	120	163.2
9/16-12	65	88.4	110	149.6	150	204.0
9/16-18	75	102.0	120	163.2	170	231.2
5/8-11	90	122.4	150	204.0	220	299.2
5/8-18	100	136	180	244.8	240	326.4
3/4-10	160	217.6	260	353.6	386	525.0
3/4-16	180	244.8	300	408.0	420	571.2
7/8-9	140	190.4	400	544.0	600	816.0
7/8-14	155	210.8	440	598.4	660	897.6
1-8	220	299.2	580	788.8	900	1,244.0
1-12	240	326.4	640	870.4	1,000	1,360.0

### NOTES

- These torque values are to be used for all hardware excluding: locknuts, self-tapping screws, thread forming screws, sheet metal screws and socket head setscrews.
- Recommended seating torque values for locknuts:
  - for prevailing torque locknuts - use 65% of grade 5 torques.
  - for flange whizlock nuts and screws - use 135% of grade 5 torques.
- Unless otherwise noted on assembly drawings, all torque values must meet this specification.

## Wrench & Fastener Size Guide

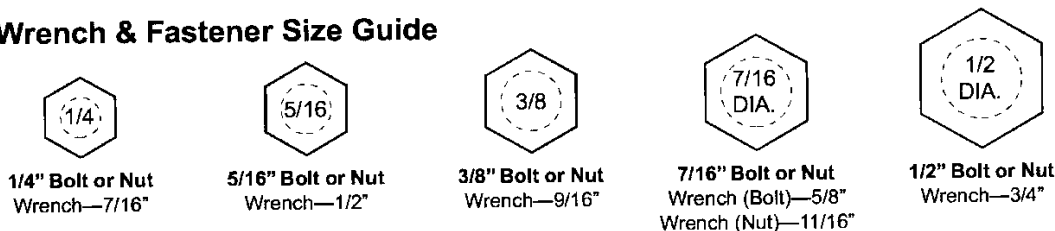

## ***Hardware Identification & Torque Specifications***

---

<b>Item</b>	<b>Part No</b>	<b>Qty</b>	<b>Description</b>	<b>Note</b>
				Chart for hardware I.D. & torque specs.

**Footnotes:**











*Parts Manual for*  
**GIANT-VAC<sup>®</sup>**

**FIELD & BRUSH MOWER  
SERIES 0**

IT IS THE POLICY OF SNAPPER TO IMPROVE ITS PRODUCTS  
WHENEVER IT IS POSSIBLE AND PRACTICAL TO DO SO. WE  
RESERVE THE RIGHT TO MAKE CHANGES OR ADD IMPROVEMENTS  
AT ANY TIME WITHOUT INCURRING ANY OBLIGATION TO MAKE  
SUCH CHANGES ON PRODUCTS MANUFACTURED PREVIOUSLY.

**GIANT-VAC<sup>®</sup>**